

Carrying handle

Description

This carrying handle is to be used with Panasonic projectors.

Specifications

Dimensions (W x H x D): 697 x 120 x 509 mm
 (27-7/16" x 4-23/32" x 20-1/32")
 Weight: 5.1 kg (11.2 lbs)

Weights and dimensions shown are approximate. Specifications subject to change without notice.

Parts

- Carrying handle 1
- Carrying handle fixing screw (M6 x 25) 5
- Adjuster (projector legs are used as adjusters) 4

Dimensions

Illustration shows the ET-HAD100 attached to the projector.

The legs attached to the projector main unit are used as adjusters for this carrying handle.

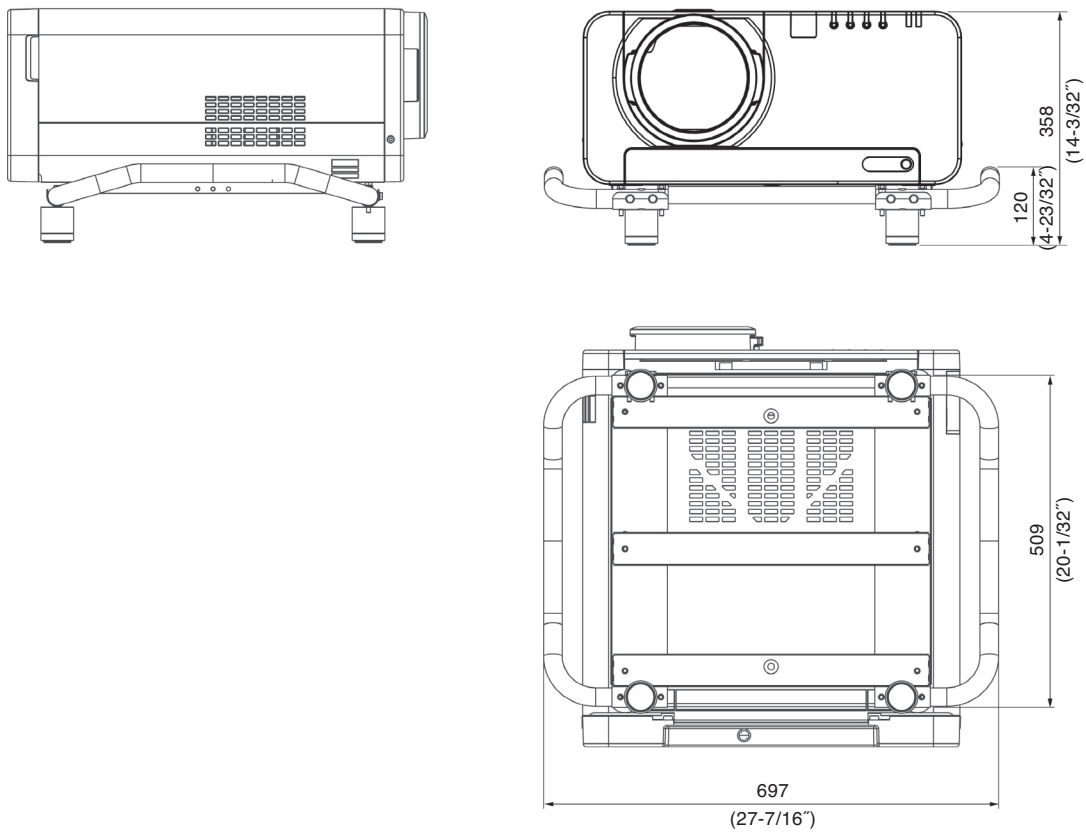

unit : mm (inch)
 NOTE: This illustration is not drawn to scale.