

S P E C F I L E

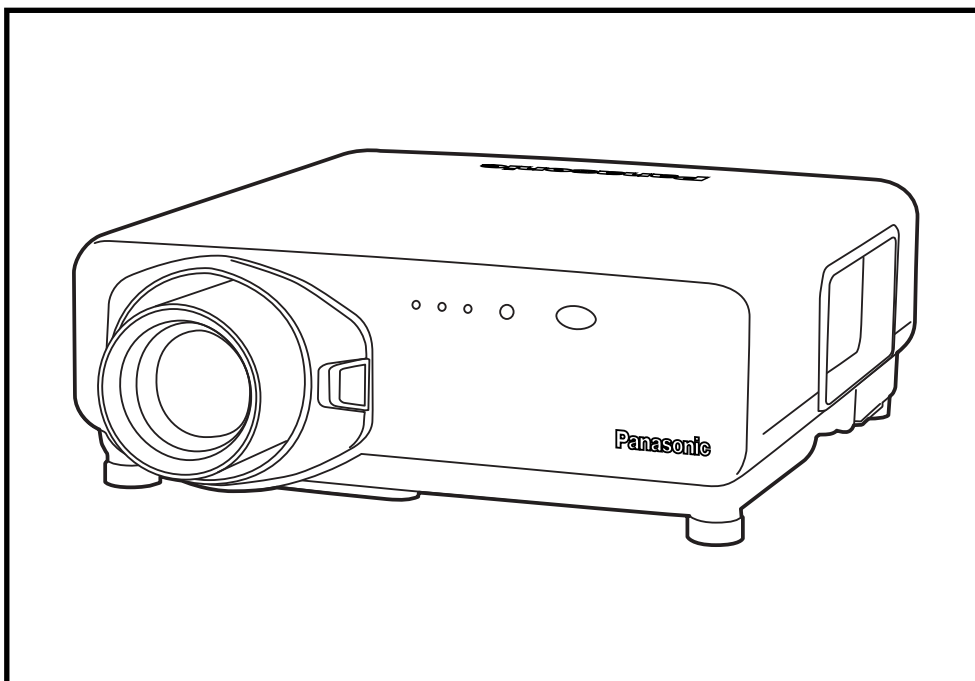

Product Number : **PT-DW7000**

Product Name : 3-Chip DLP™ Projector

Specifications

Main Unit

Power supply:	North America:	120 V AC, 20 A, 60 Hz
	Europe, Asia	220–240 V AC, 15 A, 50/60 Hz
Power consumption:		800 W (800 VA)(North America: 12 W in standby mode with fan stopped, Europe: 15 W in standby mode with fan stopped)
DLP™ chip:	Panel size:	0.85" diagonal (16:9 aspect ratio)
	Display method:	DLP™ device x 3 (R, G, B), DLP™ projection system
	Pixels:	1,049,088 (1,366 x 768) x 3, total of 3,147,264 pixels
Lens:		Optional powered zoom/focus lenses
Lamp:		300 W UHM lamp x 2
Screen size:		70–600 inches, 16:9 aspect ratio (70–300 inches with the ET-D75LE5, 16:9 aspect ratio)
Brightness*1:		6,000 lumens (four-lamp operation mode)
Center-to-corner uniformity*1:		90%
Contrast*1:		4,000:1 (full on/full off, in dynamic iris 3 mode)
Resolution:		1,300:1 (full on/full off, with dynamic iris off) 1,366 x 768 pixels (Input signals that exceed this resolution will be converted to 1,366 x 768 pixels.)
Scanning frequency:	RGB:	Horizontal: 15–100 kHz, Vertical: 24–120 Hz*2, Dot clock: 20–162 MHz
	YPbPr (YCbCr):	480i: fh 15.75 kHz; fv 60 Hz, 576i: fh 15.63 kHz; fv 50 Hz, 480p: fh 31.50 kHz; fv 60 Hz, 576p: fh 31.25 kHz; fv 50 Hz, 720/60p: fh 45.00 kHz; fv 60 Hz, 1035/60i: fh 33.75 kHz; fv 60 Hz, 1080/60i: fh 33.75 kHz; fv 60 Hz, 1080/50i: fh 28.13 kHz; fv 50 Hz, 1080/25p: fh 28.13 kHz; fv 25 Hz, 1080/24p: fh 27.00 kHz; fv 24 Hz, 1080/24sF: fh 27.00 kHz; fv 48 Hz, 1080/30p: fh 33.75 kHz; fv 30 Hz
	S-Video/Video:	Horizontal: 15.75/15.63 kHz, Vertical: 50/60 Hz, (NTSC, NTSC4.43, PAL, PAL60, PAL-N, PAL-M, SECAM)
Optical axis shift*:	Vertical:	±70% (±60% with the ET-D75LE6) from center of screen, powered
	Horizontal:	±30% from center of screen, powered
Keystone correction range:		Vertical: ±40° (±34° with the ET-D75LE1, ±19° with the ET-D75LE5, ±28° with the ET-D75LE6)
Installation:		Ceiling/floor, front/rear
Terminals:	RGB1 IN:	BNC x 5
	R, G, B:	G: 0.7 Vp-p (1.0 Vp-p for sync on G), 75 ohms, B, R: 0.7 Vp-p, 75 ohms HD, VD, SYNC: 1.4–5.0 Vp-p, positive/negative automatic
	Y, Pb, Pr	Y: 1.0 p-p, 75 ohms (incl. sync signal), Pb/Pr: 0.7 Vp-p, 75 ohms 0.7 Vp-p (1.0 Vp-p for sync on G), 75 ohms
	RGB2 IN:	D-sub HD 15-pin (female) x 1
	R, G, B:	G: 0.7 Vp-p (1.0 Vp-p for sync on G), 75 ohms, B, R: 0.7 Vp-p, 75 ohms HD, VD, SYNC: TTL, positive/negative automatic
	Y, Pb, Pr	Y: 1.0 p-p, 75 ohms (incl. sync signal), Pb/Pr: 0.7 Vp-p, 75 ohms 0.7 Vp-p (1.0 Vp-p for sync on G), 75 ohms

VIDEO IN:	BNC x 1, 1.0 Vp-p, 75 ohms
VIDEO OUT:	BNC x 1, 1.0 Vp-p, 75 ohms, active through
S-VIDEO IN:	Mini DIN 4-pin x 1
	Y: 1.0 Vp-p, C: 0.286 Vp-p, 75 ohms
SERIAL IN**:	D-sub 9-pin (female) x 2, for external control (RS-232C/RS-422 compliant)
SERIAL OUT**:	D-sub 9-pin (male) x 1, for link control
REMOTE 1 IN:	M3 jack x 1 for wired remote control
REMOTE 1 OUT:	M3 jack x 1 for link control
REMOTE 2 IN:	D-sub 9-pin (female) x 1 for external control (parallel)
Optional board slot*5:	x 1
With ET-MD77SD1 installed:	SERIAL IN: BNC x 1, SD-SDI signal (4:2:2), SMPTE 259M compliant, 480i, 576i
	SERIAL OUT: BNC x 1, active through
	LAN: RJ-45 x 1, for network connection, 10Base-T/100Base-TX
With ET-MD77SD3 installed:	SERIAL IN: BNC x 1
	SD-SDI signal (4:2:2): SMPTE 259M compliant, 480i, 576i
	Single-link HD-SDI signal (YPbPr 4:2:2 10-bit): SMPTE 292M compliant, 720/50p, 720/60p, 1080/50i, 1080/60i, 1080/25p, 1080/24p, 1080/24sF, 1080/30p
	SERIAL OUT: BNC x 1, active through
	LAN: RJ-45 x 1, for network connection, 10Base-T/100Base-TX
With ET-MD77DV installed:	DVI-D IN: DVI-D 24-pin x 1, DVI 1.0 compliant, compatible with HDCP, compatible with single link only
	EDID1: 480p, 576p, 720/60p, 720/50p, 1080/60i, 1080/50i, 1080/24p, 1080/24sF, 1080/25p, 1080/30p
	EDID2: Compatible with non-interlaced signals only, Effective resolution: VGA (640 x 480)–U-XGA (1,600 x 1,200), Dot clock: 25–162 MHz
With ET-MD77NT installed:	LAN: RJ-45 x 1, for network connection, 10Base-T/100Base-TX
Power cord:	2.5 m/8'2"
Cabinet material:	Moulded plastic
Dimensions (W x H x D):	530 x 200 x 569 mm (20-7/8" x 7-7/8" x 22-13/32") (without lens)
Weight:	22 kg (48.5 lbs) or less (without lens)
Operating temperature*6:	0°–40°C (32°–104°F)
Operating humidity:	10%–80% (no condensation)
Remote Control Unit	
Number of functions:	32 keys, 46 functions
Power supply:	3 V DC (AA battery x 2)
Operation range*7:	Wireless: Approx. 7 m/23' when operated from directly signal receptor Wired: Approx. 15 m/49'3"
Dimensions (W x H x D):	50 x 31 x 181 mm (1-31/32" x 1-7/32" x 7-1/8")
Weight:	110 g (3.9 oz) (including batteries)

Supplied Accessories

Power cord, wireless/wired remote control, AA batteries for remote control (x 2), remote control cable (15 m/49'3")

Optional Accessories

Zoom lens (1.0–1.2:1):	ET-D75LE6
Zoom lens (1.5–2.0:1):	ET-D75LE1
Zoom lens (2.1–3.1:1):	ET-D75LE2
Zoom lens (3.1–5.2:1):	ET-D75LE3
Zoom lens (5.2–8.2:1):	ET-D75LE4
Zoom lens (8.2–15.4:1):	ET-D75LE8
Fixed-focus lens (0.8:1):	ET-D75LE5
SD-SDI board:	ET-MD77SD1
HD/SD-SDI board:	ET-MD77SD3
DVI-D board:	ET-MD77DV
Network board:	ET-MD77NT
Wireless mouse receiver	ET-RMRC2
Replacement lamp unit	ET-LAD7700 (one bulb) ET-LAD7700W (a set of two bulbs)
Replacement long-life lamp unit	ET-LAD7700L (one bulb) ET-LAD7700LW (a set of two bulbs)
Ceiling mount bracket for high ceilings	ET-PKD77H
Ceiling mount bracket for low ceilings	ET-PKD75S
Dual stacking mount bracket	ET-DFD75
Carrying handle	ET-HAD75

Weights and dimensions shown are approximate. Specifications subject to change without notice.

*1 Values indicate overall average values of the product at the time of shipment and are stated based on JIS X 6911:2003 Data Projector Specification Sheet Format. Measurement method and conditions are based on Appendix 2.

*2 Smooth image reproduction may not be possible when a motion video signal with a vertical frequency other than 50 or 60 Hz is input.

*3 Shift range is limited during simultaneous horizontal and vertical shifting.

*4 Contact your dealers for details when the control using RS-232C or RS-422 is required.

*5 The LAN terminal on the optional board will be inactivated after installation. Use the LAN terminal on the main unit.

*6 Operating temperature is 0°C–40°C (32°F–104°F) when the fan control is set to "HIGHLAND" (for over 1,400 m to 2,700 m above sea level).

*7 Operation range differs depending on environments.

Dimensions

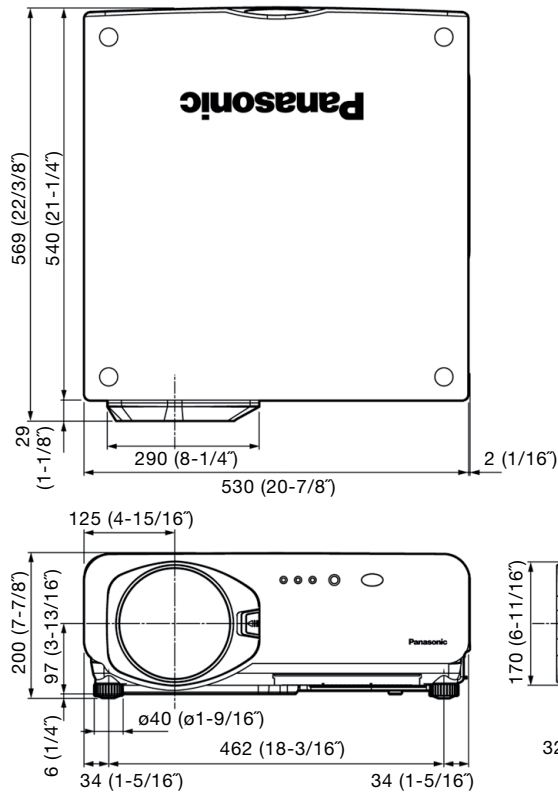

unit : mm (inch)
NOTE: This illustration is not drawn to scale.

Terminals

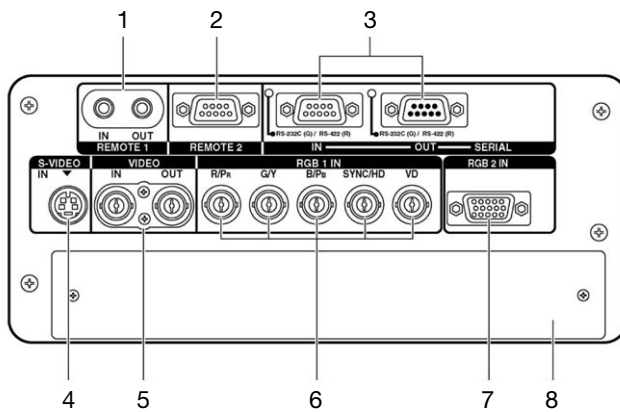

- 1 Remote 1 input/output
- 2 Remote 2 input
- 3 Serial input/output
- 4 S-Video input
- 5 Video input/output
- 6 RGB 1 input
- 7 RGB 2 input
- 8 Optional board slot

Standard setting-up positions

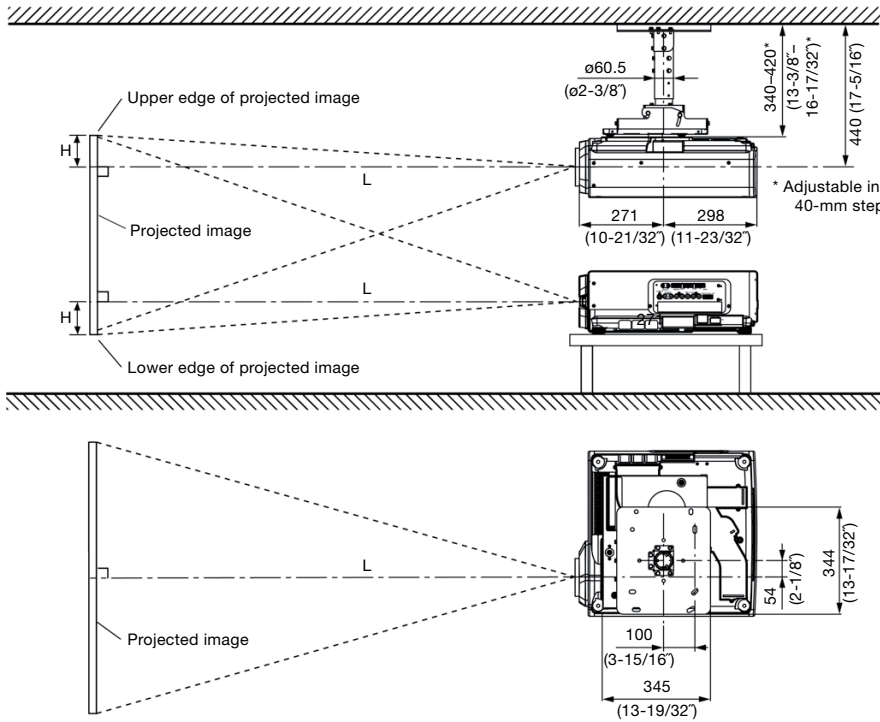

NOTE:

Illustrations show the projector installed using optional ceiling bracket ET-PKD75H and an optional lens ET-D75LE1.

This illustration is not drawn to scale.

unit : mm (inch)

Projection distance (screen aspect ratio 16:9)

Lens (Throw ratio)*	Distance to screen												Fixed-focus	Height from the edge of screen to center of lens (H)				
	Zoom													ET-D75LE5 Fixed-focus lens (0.8:1)	Zoom lenses		Fixed-focus lens	
	ET-D75LE6 Zoom lens (1.0-1.2:1)		ET-D75LE1 Zoom lens (1.5-2.0:1)		ET-D75LE2 Zoom lens (2.1-3.1:1)		ET-D75LE3 Zoom lens (3.1-5.2:1)		ET-D75LE4 Zoom lens (5.2-8.2:1)		ET-D75LE8 Zoom lens (8.2-15.4:1)				Zoom lenses	ET-D75LE6		
Screen size (inch, diagonal)	min.	max.	min.	max.	min.	max.	min.	max.	min.	max.	min.	max.	min.	max.	min.	max.	min.	max.
70	1,560 5.2	1,865 6.1	2,322 7.7	3,103 10.1	3,137 10.3	4,719 15.5	4,730 15.6	7,937 26.0	7,943 26.1	12,713 40.7	12,430 40.8	23,653 77.5	1,151 3.8	-174 - 1,046 -0.57 - 3.43	-87 - 959 -0.29 - 3.15	436 1.43		
80	1,791 5.9	2,142 7.0	2,664 8.8	3,561 11.6	3,597 11.9	5,408 17.7	5,419 17.8	9,088 29.8	9,094 29.9	14,544 46.7	14,261 46.8	27,083 88.8	1,328 4.4	-199 - 1,195 -0.65 - 3.92	-100 - 1,096 -0.33 - 3.60	498 1.63		
100	2,253 7.4	2,696 8.8	3,349 9.9	4,476 13.1	4,516 13.4	6,787 20.0	6,797 20.1	11,391 33.5	11,397 33.7	18,206 52.7	17,922 52.8	33,644 100.1	1,681 4.9	-249 - 1,494 -0.82 - 4.90	-125 - 1,370 -0.41 - 4.49	561 1.84		
110	2,484 8.2	2,973 9.7	3,692 11.0	4,934 14.6	4,976 14.9	7,476 22.3	7,487 22.3	12,542 37.3	12,548 37.4	20,036 58.8	19,754 58.9	37,374 111.3	1,857 5.5	-274 - 1,644 -0.90 - 5.39	-137 - 1,507 -0.45 - 4.94	685 2.04		
120	2,715 9.0	3,250 10.6	4,035 13.3	5,392 17.6	5,435 17.9	8,166 26.8	8,176 26.9	13,693 44.9	13,699 45.0	21,867 70.8	21,584 70.9	40,804 133.8	2,033 6.7	-299 - 1,793 -0.98 - 5.88	-149 - 1,644 -0.49 - 5.39	747 2.45		
150	3,408 11.2	4,081 13.3	5,062 16.7	6,765 22.1	6,814 22.4	10,234 33.6	10,244 33.7	17,147 56.2	17,153 56.3	27,359 88.8	27,077 88.9	51,095 167.6	2,563 8.4	-374 - 2,241 -1.23 - 7.35	-187 - 2,055 -0.61 - 6.74	934 3.06		
200	4,563 15.0	5,466 17.9	6,775 22.3	9,053 29.7	9,112 29.9	13,680 44.9	13,691 45.0	22,904 75.1	22,909 75.2	36,512 118.8	36,231 118.9	68,247 223.9	3,445 11.3	-498 - 2,989 -1.63 - 9.80	-249 - 2,740 -0.82 - 8.99	1,245 4.09		
250	5,718 18.8	6,851 22.4	8,488 27.9	11,341 37.2	11,409 37.5	17,127 56.2	17,137 56.3	28,660 94.0	28,666 94.1	45,666 148.9	45,385 149.0	85,399 280.1	4,327 14.2	-623 - 3,736 -2.04 - 12.26	-311 - 3,424 -1.02 - 11.23	1,557 5.11		
300	6,873 22.6	8,236 27.0	10,201 33.5	13,630 44.7	13,707 45.0	20,574 67.5	20,584 67.6	34,416 112.9	34,422 113.0	54,819 178.9	54,540 179.0	102,550 336.4	5,209 17.1	-747 - 4,483 -2.45 - 14.71	-374 - 4,109 -1.23 - 13.48	1,867 6.13		
400	9,183 30.2	11,006 36.1	13,626 44.8	18,206 59.7	18,303 60.1	27,467 90.1	27,477 90.2	45,929 150.6	45,934 150.8	73,126 239.0	72,848 239.1	136,854 448.9	-	-996 - 5,977 -3.27 - 19.61	-498 - 5,479 -1.63 - 17.98	-		
500	11,493 37.8	13,776 45.2	17,052 56.0	22,783 74.7	22,898 75.2	34,360 112.7	34,371 112.8	57,441 188.4	57,447 188.5	91,433 299.0	91,157 299.1	171,157 561.5	-	-1,245 - 7,472 -4.09 - 24.51	-623 - 6,849 -2.04 - 22.47	-		
600	13,803 45.3	16,546 54.2	20,477 67.2	27,360 89.7	27,494 90.3	41,254 135.3	41,264 135.4	68,954 226.2	68,960 226.3	109,740 359.1	109,465 359.2	205,461 674.0	-	-1,494 - 8,966 -4.90 - 29.41	-747 - 8,219 -2.45 - 26.96	-		

* The throw ratio is an approximate value calculated by dividing the screen width by the projection distance.
(Throw ratio) = (screen width) / (projection distance)

millimeters
feet

- The figures in the above table may vary by approximately ±5% depending on the projection lens that is used.
- When vertical keystone correction is used, the image is corrected in the direction that reduces its projected size.
- At the shortest projection distance, the zoom lens characteristics may cause slight image distortion.
- When the ET-D75LE6 is mounted, use the shade sheet supplied with the ET-D75LE6. The lens cover supplied with the projector cannot be attached to the unit as it is.

Calculation of the projection distance

For a screen size different from the above, use the equation below to calculate the projection distance.

ET-D75LE6	16 : 9	minimum maximum	$L \text{ (mm)} = (\text{diagonal screen size in inches}) \times 23.10 - 57$ $L \text{ (mm)} = (\text{diagonal screen size in inches}) \times 27.70 - 73$
ET-D75LE1	16 : 9	minimum maximum	$L \text{ (mm)} = (\text{diagonal screen size in inches}) \times 34.26 - 76$ $L \text{ (mm)} = (\text{diagonal screen size in inches}) \times 45.77 - 101$
ET-D75LE2	16 : 9	minimum maximum	$L \text{ (mm)} = (\text{diagonal screen size in inches}) \times 45.96 - 80$ $L \text{ (mm)} = (\text{diagonal screen size in inches}) \times 68.93 - 106$
ET-D75LE3	16 : 9	minimum maximum	$L \text{ (mm)} = (\text{diagonal screen size in inches}) \times 68.93 - 96$ $L \text{ (mm)} = (\text{diagonal screen size in inches}) \times 115.13 - 122$
ET-D75LE4	16 : 9	minimum maximum	$L \text{ (mm)} = (\text{diagonal screen size in inches}) \times 115.13 - 116$ $L \text{ (mm)} = (\text{diagonal screen size in inches}) \times 183.07 - 101$
ET-D75LE8	16 : 9	minimum maximum	$L \text{ (mm)} = (\text{diagonal screen size in inches}) \times 183.09 - 386$ $L \text{ (mm)} = (\text{diagonal screen size in inches}) \times 343.03 - 360$
ET-D75LE5	16 : 9	(fixed focus)	$L \text{ (mm)} = (\text{diagonal screen size in inches}) \times 17.64 - 84$

- The figures in the above table may vary by approximately ±5% depending on the projection lens that is used.
- When vertical keystone correction is used, the image is corrected in the direction that reduces its projected size.
- At the shortest projection distance, the zoom lens characteristics may cause slight image distortion.
- When the ET-D75LE6 is mounted, use the shade sheet that is supplied with the ET-D75LE6. The lens cover that comes with the projector cannot be attached to the unit as it is.

Shift range

Optical axis shift function allows to shift the position of a projected image as shown below.

ET-D75LE1/D75LE2/D75LE3/D75LE4/D75LE8

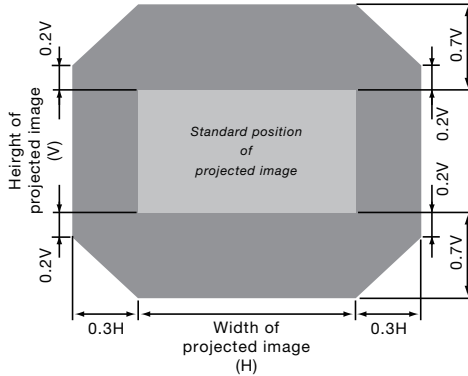

ET-D75LE6

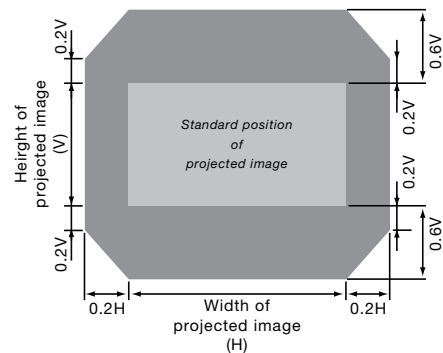

- Because the ETD75LE5 is a fixed short-throw lens, the lens shift function cannot be used with it.

Installable angle

Install the projector at an angle within the range shown right.

- **Vertical direction**
The projector may be installed at a vertical angle of 360 degrees.

- **Horizontal direction**
The projector may be installed at a horizontal angle of ±10 degrees.

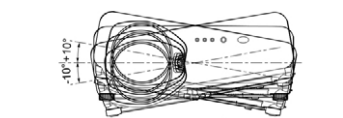
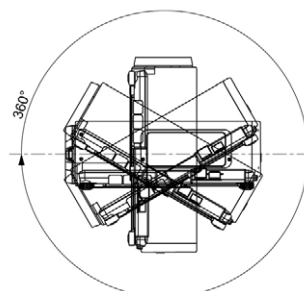

List of compatible signals

This projector supports RGB signals with horizontal frequencies of 15 to 100 kHz, vertical frequencies of 24 to 120 Hz and dot clock frequencies of 20 to 162 MHz.

NOTE: The native resolution of this projector is 1,366 x 768 pixels. If the display resolution of the input signal is different from the native resolution, image compression or expansion will be used to convert the input signal to a level within the native resolution.

Display mode	Display resolution (dots) ¹	Scanning frequency	
		Horizontal (kHz)	Vertical (kHz)
NTSC/NTSC4.43/PAL-M/PAL60	720 x 480i	15.7	59.9
PAL/PAL-N/SECAM	720 x 576i	15.6	50.0
525i (480i)	720 x 480i	15.73	59.9
625i (576i)	720 x 576i	15.62	50.0
525p (480p)	720 x 483	31.57	59.9
625p (576p)	720 x 576	31.25	50.0
1125 (1080)/60i	1,920 x 1,080i	33.75	60.0
1125 (1080)/50i	1,920 x 1,080i	28.13	50.0
1125 (1080)/24p	1,920 x 1,080	27.00	24.0
1125 (1080)/24sF	1,920 x 1,080i	27.00	24.0
1125 (1080)/25p	1,920 x 1,080	28.10	25.0
1125 (1080)/30p	1,920 x 1,080	33.75	30.0
1125 (1035)/60i	1,920 x 1,080	33.75	59.9
750 (720)/60p	1,280 x 720	45.00	60.0
750 (720)/50p	1,280 x 720	37.50	50.0
VGA400	640 x 400	24.80	56.4
		31.50	70.1
VGA480	640 x 480	31.47	59.9
		35.00	66.7
		37.86	72.8
		37.50	75.0
		43.27	85.0
SVGA	800 x 600	32.10	51.0
		35.16	56.3
		37.88	60.3
		48.08	72.2
		46.88	75.0
		53.64	85.1
MAC16	832 x 624	49.73	74.6
XGA	1,024 x 768	48.36	60.0
		56.48	70.1
		60.02	75.0
		65.50	81.6
		68.68	85.0
		80.70	100.8
		94.00	120.0
	1,024 x 768i	35.52	87.0
MXGA	1,152 x 864	64.00	70.0
		67.50	74.9
		77.10	85.0
	1,120 x 750	50.10	60.1
	1,120 x 750i	32.60	80.0
MAC21	1,152 x 870	68.68	75.1
SXGA	1,280 x 1,024	52.35	50.0
		63.98	60.0
		78.20	71.7
		79.98	75.0
		91.15	85.0
	1,280 x 1,024i	46.20	86.0
		47.60	89.9
SXGA+	1,400 x 1,050	65.20	60.0
		78.80	72.0
		82.20	75.0
UXGA60	1,600 x 1,200	75.00	60.0

1. The "i" appearing after the resolution indicates an interlaced signal.
Line flicker occurs when an interlaced signal is input.

Serial connector

The serial connector complies with RS-232C. To control the projector from a personal computer, commands must be input through communication software, based on the format and satisfying the communication conditions shown below.

Pin assignments and signal names

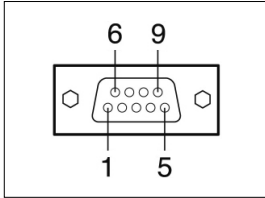

D-sub 9-pin (female)
Serial input

No.	Signal name	Description	No.	Signal name	Description
1	-	NC	6	-	NC
2	TXD	Send data	7	CTS	Connected internally
3	RXD	Receive data	8	RTS	Connected internally
4	-	Connected internally	9	-	NC
5	GND	Ground			

Pin assignments and signal names

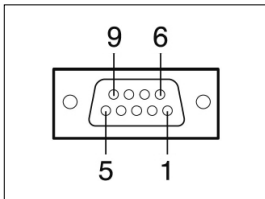

D-sub 9-pin (male)
Serial output

No.	Signal name	Description	No.	Signal name	Description
1	-	NC	6	-	NC
2	RXD	Receive data	7	RTS	Connected internally
3	TXD	Send data	8	CTS	Connected internally
4	-	Connected internally	9	-	NC
5	GND	Ground			

Communication conditions (factory setting)

Signal level	RS-232C-compliant
Synchronization method	Start-stop synchronization
Baud rate	9,600 bps
Parity	None
Character length	8 bits
Stop bit	1 bit
X parameter	None
S parameter	None

Basic format

Transmission from the computer begins with STX, then the ID, command, parameter, and ETX are sent in this order. Add parameters according to the details of control.

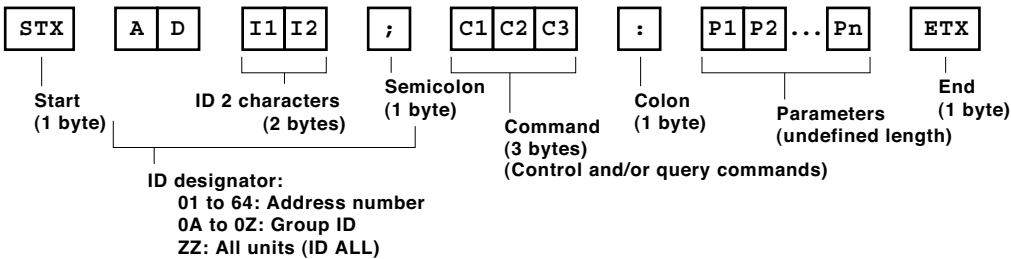

CAUTION

- It may not be possible to send or receive commands for about 10 to 60 seconds when the lamp is first turned on. If this occurs, wait for 60 seconds, then try sending or receiving again.
- When sending multiple commands, be sure to wait for at least 0.5 second after receiving a response from the projector before sending the next command.
- Additional time is sometimes required for response due to processing inside the projector. Set the time-out period for command response to 10 seconds or more.

Cable specifications

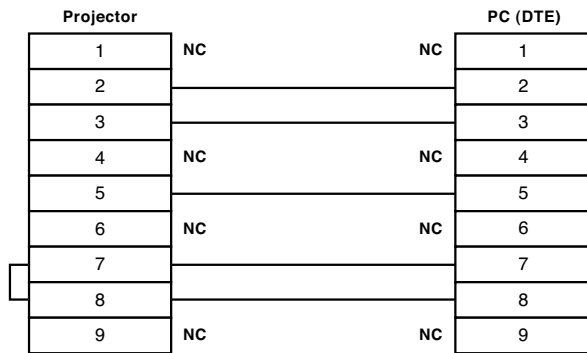

Control commands

Command : Parameter	Function		Callback
PON	POWER (STANDBY)	Standby power on	PON
POF		Standby power off	POF
IIS:RG1	INPUT SELECT	RGB 1	IIS:RG1
IIS:RG2		RGB 2	IIS:RG2
IIS:VID		Video	IIS:VID
IIS:SVD		S-Video	IIS:SVD
IIS:AUX		AUX	IIS:AUX
LPM:0	LAMP SELECT	Dual (two lamps)	LPM:0
LPM:1		Single lamp	LPM:1
LPM:2		Lamp 1	LPM:2
LPM:3		Lamp 2	LPM:3
OSH:1	SHUTTER	Shutter on	OSH:1
OSH:0		Shutter off	OSH:0
OPP:0	P IN P SELECT	P in P off	OPP:0
OPP:1		User 1	OPP:1
OPP:2		User 2	OPP:2
OPP:3		User 3	OPP:3
OAS	AUTO SETUP		OAS
VPM:NAT	PICTURE MODE	Natural	VPM:NAT
VPM:STD		Standard	VPM:STD
VPM:DYN		Dynamic	VPM:DYN
VPM:CIN		Cinema	VPM:CIN
VPM:GRA		Graphic	VPM:GRA
OTE:0	COLOR TEMPERATURE	Low	OTE:0
OTE:1		Middle	OTE:1
OTE:2		High	OTE:2
OTE:4		User 1	OTE:4
OTE:9		User 2	OTE:9
OTE:10		Default	OTE:10
TSD:y1y2y3y4m1m2d1d2w		DATE	Date setting
TST:h1h2m1m2s1s2	TIME	Time setting	TST:h1h2m1m2s1s2
OOS:1	ON SCREEN	On-screen display on	OOS:1
OOS:0		On-screen display off	OOS:0

Status asking commands

Command:Parameter	Function	Callback	Description
QPW	Main power status	001	On
		000	Off
QSH	Shutter function status	1	On
		0	Off
QIN	Input signal status	RG1	RGB 1
		RG2	RGB 2
		VID	Video
		SVD	S-Video
		AUX	AUX
QOS	On-screen display status	1	On
		0	Off
QST	Projector run time	00000-99999	0000h-99999h
Q\$L:1	Lamp 1 run time	0000-9999	0000h-9999h
Q\$L:2	Lamp 2 run time	0000-9999	0000h-9999h
QSL	Lamp operation mode status	0	Dual (two lamps)
		1	Single lamp
		2	Lamp 1
		3	Lamp 2
QIB	Optional board slot status	MD95SD1	ET-MD95SD1
		MD95SD3	ET-MD95SD3
		MD75DV	ET-MD75DV
		NONE	Uninstalled
		UNKNOWN	Unknown
QPP	P in P status	NOT SUPPORT	Not supported
		0	Off
		1	User 1
		2	User 2
		3	User 3
QGD	Date setting status	y1y2y3y4m1m2d1d2w	yyyymmdd (day of week) (*1)
QGT	Time setting status	h1h2m1m2s1s2	hhmmss (*2)

*1 Day of week: Monday = 1, Tuesday = 2, ... Sunday = 7
 *2 Set the date and time to UTC (universal time coordinated).

NOTE: If a wrong command is received, the projector will send an ER401 or ER402 command to the computer.

Command example

To set the on-screen display off, send the command as shown below.

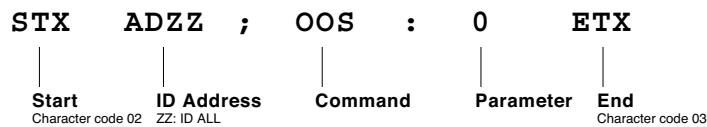

NOTE: When sending commands without parameters, a colon (:) is not necessary.

Notes on Projector Placement and Operation:

The projector uses a high-wattage lamp that becomes very hot during operation. Please observe the following precautions.

1. Never place objects on top of the projector while it is operating.
2. Make sure there is an unobstructed space of 500 mm (19-11/16") or more around the projector's exhaust openings.
3. If the projector is placed in a box or enclosure, ensure the temperature of the air surrounding the projector is between 0°C/32°F and 35°C/95°F. Also make sure the projector's intake and exhaust openings are not blocked. Take particular care to ensure that hot air from the exhaust openings is not sucked into the intake openings.

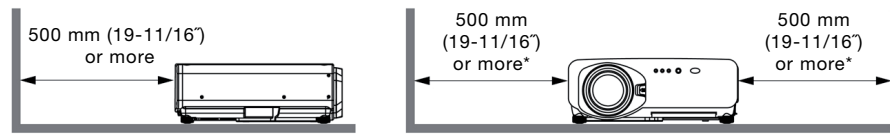

Direction of Air Intake and Exhaust

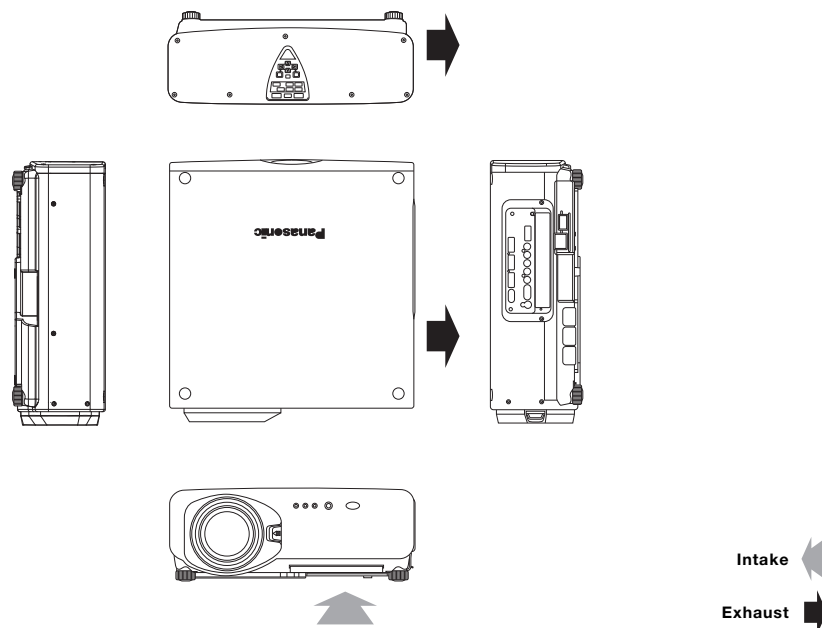

Operating the Projector Continuously

1. The lamp replacement cycle duration becomes shorter if the projector is operated continuously more than 10 hours.
2. The lamp replacement cycle duration becomes shorter if the projector is operated repeatedly for short periods.

Weights and dimensions shown are approximate. Specifications are subject to change without notice. This product may be subject to export control regulations. DLP and the DLP logo are trademarks of Texas Instruments. All other trademarks are the property of their respective trademark owners.