

---

**S P E C F I L E**

---

**Product Number :** PT-**VW340Z**

**Product Name :** LCD Projectors

Specifications

Main unit

Power supply		100 V, 100–240 V AC, 50/60 Hz
Power consumption		100–120 V: 300 W, 220–240 V: 280 W 0.4W when Standby mode set to Eco*1, 1.3W when Standby mode set to Network, 9W when Standby mode set to Normal
LCD panel	Panel size	15.0 mm (0.59 inches) diagonal (16:10 aspect ratio)
	Display method	Transparent LCD panel (× 3, R/G/B)
	Pixels	1,024,000 (1,280 × 800) × 3, total of 3,072,000 pixels
	Pixel configuration	Stripe
Lens		Manual zoom (1.6×), manual focus F 1.60–2.12, f 15.30–24.64 mm
Throw ratio		1.2–1.9:1
Lamp		230 W UHM lamp
Screen size		0.76–7.62 m (30–300 inches) diagonally, 16:10 aspect ratio
Colors		Full color (16,777,216 colors)
Brightness*2		3,700 lumens (LAMP POWER: NORMAL)
Center-to-corner uniformity*2		85%
Contrast*2		3,000:1 (full on/off, LAMP POWER: NORMAL, Iris on)
Resolution		1,280 × 800 pixels (Input signals that exceed this resolution will be converted to 1,280 × 800 pixels.)
Scanning frequency	HDMI	fH: 15–80 kHz, fV: 50–85 Hz, dot clock: 162 MHz or lower
	RGB	fH: 15–100 kHz, fV: 50–100 Hz, dot clock: 162 MHz or lower (Signals exceeding the dot clock rate of 140 MHz are downsampled.)
	YPbPr (YCbCr)	480i (525i): fH 15.75 kHz; fV 60 Hz, 576i (625i): fH 15.63 kHz; fV 50 Hz, 480p (525p): fH 31.50 kHz; fV 60 Hz, 576p (625p): fH 31.25 kHz; fV 50 Hz, 720 (750)/60p: fH 45.00 kHz; fV 60 Hz, 720 (750)/50p: fH 37.50 kHz; fV 50 Hz, 1080 (1125)/60i: fH 33.75 kHz; fV 60 Hz, 1080 (1125)/25p: fH 28.13 kHz; fV 25 Hz, 1080 (1125)/24p: fH 27.00 kHz; fV 24 Hz, 1080 (1125)/24sF: fH 27.00 kHz; fV 48 Hz, 1080 (1125)/30p: fH 33.75 kHz; fV 30 Hz, 1080 (1125)/60p: fH 67.50 kHz; fV 60 Hz, 1080 (1125)/50p: fH 56.25 kHz; fV 50 Hz, 1080 (1125)/50i: fH 28.13 kHz; fV 50 Hz
	Video/S-Video	fH: 15.75 kHz, fV: 60 Hz [NTSC/NTSC4.43/PAL-M/PAL60] fH: 15.63 kHz, fV: 50 Hz [PAL/PAL-N/SECAM]
Optical axis shift		49:1 (fixed)
Keystone correction range		Vertical: ±40°, horizontal: ±30° (when an WXGA signal is input) (vertical: ±30° (when using AUTO) (for WXGA input, max)
Installation		Ceiling/desk, front/rear (menu selection)
Built-in speaker	Size	4 cm (1-9/16 inches) (round) × 1
	Output power	10 W (monaural)
Terminals	HDMI IN	HDMI 19-pin × 1, HDCP compatible 480i (525i)*3, 576i (625i)*3, 480p (525p)*3, 576p (625p)*3, 720 (750)/60p, 720 (750)/50p, 1080 (1125)/60i, 1080 (1125)/50i, 1080 (1125)/25p, 1080 (1125)/24p, 1080 (1125)/24sF, 1080 (1125)/30p, 1080 (1125)/60p, 1080 (1125)/50p VGA (640 × 480)–WUXGA*4 (1,920 × 1,200), dot clock: 25.2 MHz–146.25 MHz; Audio signal: linear PCM (sampling frequencies: 48 kHz, 44.1 kHz, 32 kHz)
	COMPUTER (RGB) 1 IN	D-sub HD 15-pin (female) × 1
	R, G, B	G: 0.7 Vp-p (1.0 Vp-p for sync on G), 75 ohms; B, R: 0.7 Vp-p, 75 ohms; HD/VD, SYNC: high impedance, TTL (positive/negative) <b>NOTE: SYNC/HD and VD terminals do not accept tri-level sync signals.</b>
	Y, Pb (Cb), Pr (Cr)	Y: 1.0 Vp-p (including sync signal); Pb (Cb), Pr (Cr): 0.7 Vp-p, 75 ohms

COMPUTER (RGB) 2IN/ 1OUT R, G, B	D-sub HD 15-pin (female) × 1 (input/output selectable using on-screen menu) G: 0.7 Vp-p (1.0 Vp-p for sync on G), 75 ohms; B, R: 0.7 Vp-p, 75 ohms; HD/VD, SYNC: high impedance, TTL (positive/negative) <b>NOTE: SYNC/HD and VD terminals do not accept tri-level sync signals.</b>
VIDEO IN	Pin jack × 1, 1.0 Vp-p, 75 ohms
S-VIDEO IN	Mini DIN 4-pin × 1, Y: 1.0 Vp-p; C: 0.286 Vp-p, 75 ohms
AUDIO IN 1	M3 (L, R) × 1, 0.5 Vrms
AUDIO IN 2 / MIC IN	M3 (L, R) × 1, 0.5 Vrms
AUDIO IN 3	Pin jack × 2 (L/R × 1), 0.5 Vrms
AUDIO OUT	M3 (L, R) × 1 (monitor out: 0–2.0 Vrms, variable)
SERIAL IN	D-sub 9-pin (male) × 1, for external control (RS-232C compliant)
LAN	RJ-45 × 1, for network connection, 100Base-TX/10Base-T, compliant with PLink™
Power cord length	2.0 m (6 ft 7 in)
Cabinet materials	Molded plastic
Dimensions (W × H × D)	352 × 98* <sup>5</sup> × 279.4* <sup>6</sup> mm (13-27/32 × 3-27/32* <sup>5</sup> × 11* <sup>6</sup> inches)
Weight* <sup>7</sup>	Approx. 3.3 kg (7.3 lbs)
Operation noise* <sup>2</sup>	35 dB (Lamp power: Normal), 29 dB (Lamp power: Eco 1 / Eco 2)
Operating temperature	0–40 °C (32°–104°F) (At altitudes less than 1400 m, High altitude mode: OFF) 0–30 °C (32°–86°F) (At altitudes of 1400 m to 2000 m, High altitude mode: HIGH1) 0–30 °C (32°–86°F) (At altitudes of 2000 m to 2700 m, High altitude mode: HIGH2)
Operating humidity	10%–80% (no condensation)
<b>Remote control unit</b>	
Power supply	3 V DC (R03/LR03/AAA type battery × 2)
Operation range* <sup>8</sup>	Approx. 7 m (23 ft) when operated from directly in front of the signal receptor
Dimensions (W × H × D)	44 × 105 × 19.5 mm (1-23/32 × 4-1/8 × 25/32 inches)
Weight	Approx. 63 g (2.22 oz) (including batteries)
<b>Supplied accessories</b>	
	Power cord with security lock (× 1) Wireless remote control unit (× 1) Batteries for remote control (R03/LR03/AAA type × 2) VGA cable (× 1) Software CD-ROM (Logo Transfer Software, Multi Projector Monitoring and Control Software) (× 1)
<b>Optional accessories</b>	
Replacement lamp unit	ET-LAV300
Replacement filter unit	ET-RFV300
Ceiling mount bracket	ET-PKV100H (for high ceilings)
Ceiling mount bracket	ET-PKV100S (for low ceilings)
Bracket assembly	ET-PKV101B
Early Warning Software	ET-SWA100

Weights and dimensions shown are approximate. Specifications subject to change without notice.

- \*1 When the Standby mode is set to Eco, network functions such as power on over the LAN network will not operate. Also, only certain commands can be received for external control using the serial terminal.
- \*2 Measurement, measuring conditions, and method of notation all comply with ISO 21118 international standards.
- \*3 Only compatible with dot clock frequency of 27 MHz (pixel repetition signal)
- \*4 WUXGA resolution is supported only when the signals are compliant with VESA CVT-RB (Coordinated Video Timing-Reduced Blanking).
- \*5 With legs at shortest position.
- \*6 Include protruding parts.
- \*7 Average value. May differ depending on models.
- \*8 Operation range differs depending on environments.

Dimensions

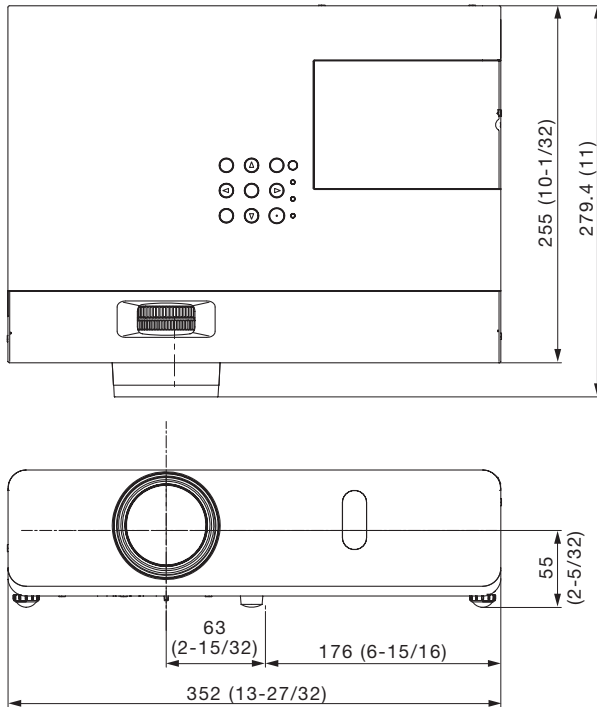

unit : mm (inch)  
NOTE: This illustration is not drawn to scale.

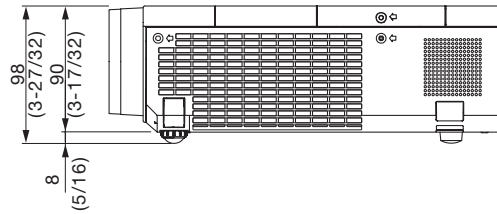

Terminals

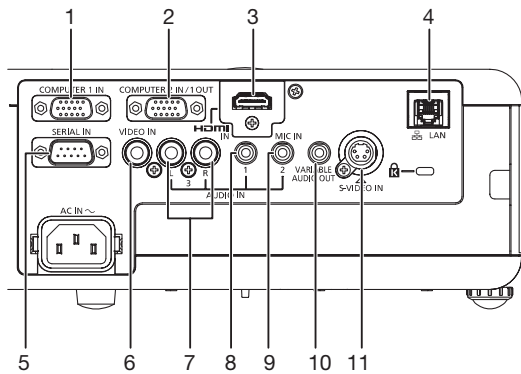

- 1 Computer 1 input
- 2 Computer 2 input / computer 1 output
- 3 HDMI input
- 4 LAN connector
- 5 Serial input
- 6 Video input
- 7 Audio input 3
- 8 Audio input 1
- 9 Audio input 2 / mic input
- 10 Audio output
- 11 S-Video input

Standard setting-up position

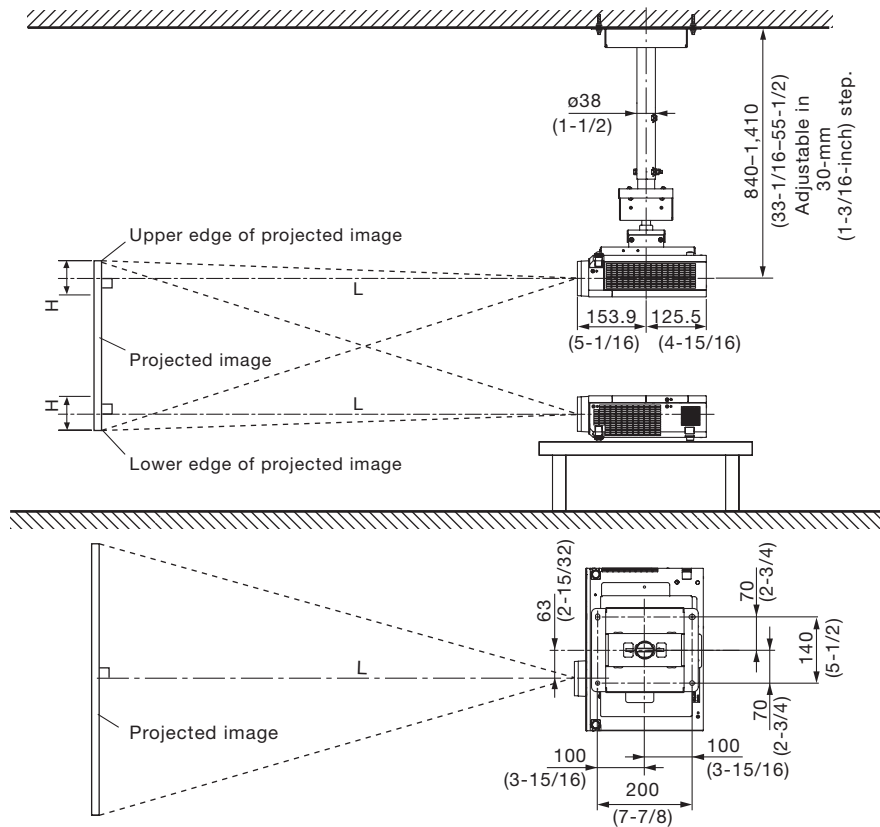

**NOTE:**  
 Illustrations show the projector installed using optional ceiling mount bracket ET-PKV100H and bracket assembly ET-PKV101B.  
 This illustration is not drawn to scale.

unit : mm (inch)

**Caution:**

- All construction work should be done by a qualified technician.
- When mounting to the ceiling, use the special mounting bracket. To prevent the projector from swaying or dropping, attach the wire that is included with the projector between the mounting bracket and the ceiling.

Projection distance for 16:10 aspect ratio screen

unit: meters (feet)

Projection size [diagonal]	Projection distance [L]		Height from the edge of screen to center of lens [H]
	Min [wide]	Max [telephoto]	
0.76 m / 30"	0.7 (2.3)	1.2 (3.9)	0.01 (0.03)
1.02 m / 40"	1.0 (3.3)	1.6 (5.2)	0.01 (0.03)
1.27 m / 50"	1.3 (4.3)	2.0 (6.6)	0.01 (0.03)
1.52 m / 60"	1.5 (4.9)	2.5 (8.2)	0.02 (0.07)
1.78 m / 70"	1.8 (5.9)	2.9 (9.5)	0.02 (0.07)
2.03 m / 80"	2.0 (6.6)	3.3 (10.8)	0.02 (0.07)
2.29 m / 90"	2.3 (7.5)	3.7 (12.1)	0.02 (0.07)
2.54 m / 100"	2.5 (8.2)	4.1 (13.5)	0.03 (0.10)
3.05 m / 120"	3.1 (10.2)	4.9 (16.1)	0.03 (0.10)
3.81 m / 150"	3.8 (12.5)	6.2 (20.3)	0.04 (0.13)
5.08 m / 200"	5.1 (16.7)	8.2 (26.9)	0.05 (0.16)
6.35 m / 250"	6.4 (21.0)	10.3 (33.8)	0.07 (0.23)
7.62 m / 300"	7.7 (25.3)	12.4 (40.7)	0.08 (0.26)

**NOTE:**

- The value for L (distance to screen) varies slightly depending on the zoom lens characteristics.
- At the shortest projection distance, the zoom lens characteristics may cause slight image distortion.

**Projection distance for 16:9 aspect ratio screen**

unit: meters (feet)

Projection size [diagonal]	Projection distance [L]		Height from the edge of screen to center of lens [H]
	Min [wide]	Max [telephoto]	
0.76 m / 30"	0.8 (2.5)	1.2 (3.9)	0.01 (0.03)
1.02 m / 40"	1.0 (3.4)	1.7 (5.6)	0.01 (0.03)
1.27 m / 50"	1.3 (4.2)	2.1 (6.9)	0.01 (0.03)
1.52 m / 60"	1.6 (5.1)	2.5 (8.2)	0.02 (0.07)
1.78 m / 70"	1.8 (6.0)	3.0 (9.8)	0.02 (0.07)
2.03 m / 80"	2.1 (6.8)	3.4 (11.2)	0.02 (0.07)
2.29 m / 90"	2.3 (7.7)	3.8 (12.5)	0.02 (0.07)
2.54 m / 100"	2.6 (8.6)	4.2 (13.8)	0.03 (0.10)
3.05 m / 120"	3.1 (10.3)	5.1 (16.7)	0.03 (0.10)
3.81 m / 150"	3.9 (12.9)	6.4 (21.0)	0.04 (0.13)
5.08 m / 200"	5.3 (17.2)	8.5 (27.9)	0.05 (0.16)
6.35 m / 250"	6.6 (21.5)	10.6 (34.8)	0.06 (0.20)
7.62 m / 300"	7.9 (25.9)	12.7 (41.7)	0.08 (0.26)

**NOTE:**

- The value for L (distance to screen) varies slightly depending on the zoom lens characteristics.
- At the shortest projection distance, the zoom lens characteristics may cause slight image distortion.

**Calculation of the projection distance**

For a screen size different from the above, use the equation below to calculate the projection distance.

Aspect ratio 16:10

minimum L (m) = (diagonal screen size in inches) × 0.0257 – 0.0294

maximum L (m) = (diagonal screen size in inches) × 0.0414 – 0.0319

Aspect ratio 16:9

minimum L (m) = (diagonal screen size in inches) × 0.0264 – 0.0294

maximum L (m) = (diagonal screen size in inches) × 0.0426 – 0.0319

**NOTE:**

Distances calculated with the above equations will include a slight error.

**Installable angle**

Install the projector at an angle within the range shown below.

• **Vertical direction**

The projector may be installed at a vertical angle of 40°.

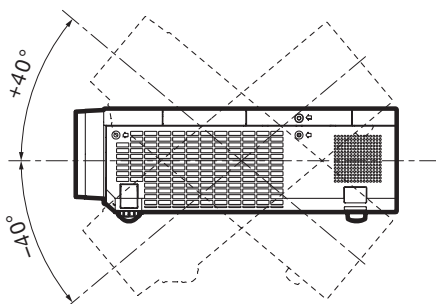

• **Horizontal direction**

The projector may be installed at a horizontal angle of 15°.

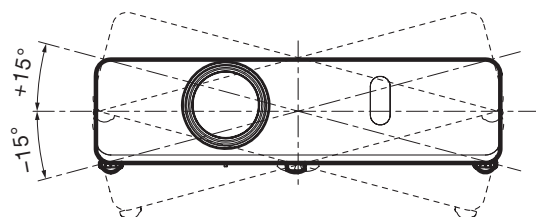

**List of compatible signals**

The signals that can be input to this projector are shown in the table below. Horizontal scanning frequencies of 15 kHz to 80 kHz (15 kHz to 100 kHz for RGB signals), vertical scanning frequencies of 50 Hz to 120 Hz (50 Hz to 100 Hz for RGB signals), and a dot clock of 162 MHz maximum for RGB signals) can be input.

**NOTE:** The native resolution of this projector is 1,280 × 800 pixels. If the display resolution of the input signal is different from the native resolution, image compression or expansion will be used to convert the input signal to a level within the native resolution.

Display mode	Display resolution (dots)*1	Scanning frequency		Dot clock frequency (MHz)	Format
		H (kHz)	V (kHz)		
NTSC/NTSC4.43/PAL-M/PAL60	720 × 480i	15.7	59.9	–	VIDEO
PAL/PAL-N/SECAM	720 × 576i	15.6	50.0	–	
480i(525i)	720 × 480i	15.7	59.9	13.5	YPbPr(YCbCr)/RGB
576i(625i)	720 × 576i	15.6	50.0	13.5	
480i(525i)	720(1440) × 480i*2	15.7	59.9	27.0	HDMI
576i(625i)	720(1440) × 576i*2	15.6	50.0	27.0	
480p(525p)	720 × 483	31.5	59.9	27.0	HDMI/
576p(625p)	720 × 576	31.3	50.0	27.0	YPbPr(YCbCr)/RGB
720(750)/60p	1280 × 720	45.0	60.0	74.3	
720(750)/50p		37.5	50.0	74.3	
1080(1125)/60i*3	1920 × 1080i	33.8	60.0	74.3	
1080(1125)/50i		28.1	50.0	74.3	
1080(1125)/24p	1920 × 1080	27.0	24.0	74.3	
1080(1125)/24sF	1920 × 1080i	27.0	48.0	74.3	
1080(1125)/25p	1920 × 1080	28.1	25.0	74.3	
1080(1125)/30p		33.8	30.0	74.3	
1080(1125)/60p		67.5	60.0	148.5	
1080(1125)/50p		56.3	50.0	148.5	
VESA400	640 × 400	37.9	85.1	31.5	HDMI/RGB
VGA	640 × 400	31.5	70.1	25.2	
	640 × 480	31.5	59.9	25.2	
		35.0	66.7	30.2	
		37.9	72.8	31.5	
		37.5	75.0	31.5	
		43.3	85.0	36.0	
SVGA	800 × 600	35.2	56.3	36.0	
		37.9	60.3	40.0	
		48.1	72.2	50.0	
		46.9	75.0	49.5	
		53.7	85.1	56.3	
MAC16	832 × 624	49.7	74.6	57.3	
XGA	1024 × 768	39.6	50.0	51.9	
		48.4	60.0	65.0	
		56.5	70.1	75.0	
		60.0	75.0	78.8	
		65.5	81.6	86.0	
		68.7	85.0	94.5	
		80.0	100.0	105.0	
MXGA	1152 × 864	64.0	70.0	94.2	
		67.5	74.9	108.0	
		77.1	85.0	119.7	
MAC21	1152 × 870	68.7	75.1	100.0	
1280 × 720	1280 × 720	37.1	50.0	60.5	
		44.8	60.0	74.5	

\*1 The "i" appearing after the resolution indicates an interlaced signal.  
 \*2 Only compatible with dot clock frequency of 27 MHz (pixel repetition signal)  
 \*3 When a 1125 (1035)/60i signal was input, it is displayed as a 1125 (1080)/60i signal.

Display mode	Display resolution (dots)*1	Scanning frequency		Dot clock frequency (MHz)	Format
		H (kHz)	V (kHz)		
1280 × 768	1280 × 768	60.3	74.9	102.3	HDMI/RGB
		68.6	84.8	117.5	
1280 × 800	1280 × 800	41.2	50.0	68.6	
		49.7	60.0	83.5	
MSXGA	1280 × 960	60.0	60.0	108.0	
SXGA	1280 × 1024	64.0	60.0	108.0	
		80.0	75.0	135.0	
		91.1	85.0	157.5	
1366 × 768	1366 × 768	39.6	50.0	69.9	
		47.7	60.0	84.7	
SXGA+	1400 × 1050	65.2	60.0	122.6	
		82.2	75.0	155.9	
WXGA+	1440 × 900	55.9	60.0	106.5	
1600 × 900	1600 × 900	46.3	50.0	97.0	
		55.9	60.0	119.0	
		75.0	60.0	162.0	
UXGA	1600 × 1200	75.0	60.0	162.0	
WSXGA+	1680 × 1050	65.2	60.0	147.1	
1920 × 1080	1920 × 1080*2	66.6	59.9	138.5	
WUXGA	1920 × 1200*2	74.0	60.0	154.0	

\*1 The "i" appearing after the resolution indicates an interlaced signal.

\*2 WUXGA resolution is supported only when the signals are compliant with VESA CVT-RB (Coordinated Video Timing-Reduced Blanking).



**Serial connector**

The serial connector complies with RS-232C. To control the projector from a personal computer, commands must be input through communication software, based on the format and satisfying the communication conditions shown below.

**Pin assignments and signal names**

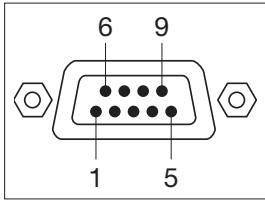

D-sub 9-pin (male)  
Serial input

No.	Signal name	Description	No.	Signal name	Description
1	-	NC	6	-	NC
2	TXD	Send data	7	CTS	Connected internally
3	RXD	Receive data	8	RTS	Connected internally
4	-	NC	9	-	NC
5	GND	Ground			

**Communication conditions (factory setting)**

Signal level	RS-232C-compliant
Synchronization method	Start-stop synchronization
Baud rate	9,600 bps
Parity	None

Character length	8 bits
Stop bit	1 bit
X parameter	None
S parameter	None

**Basic format**

Transmission from the computer begins with STX, then command, parameter, and ETX are sent in this order. Add parameters according to the details of control.

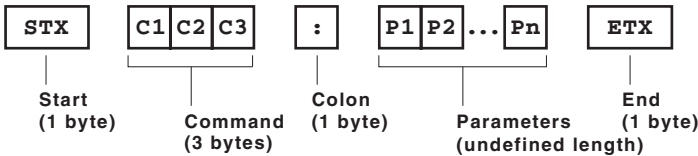

NOTE: When sending commands without parameters, a colon (:) is not necessary.

**Basic format with sub-commands**

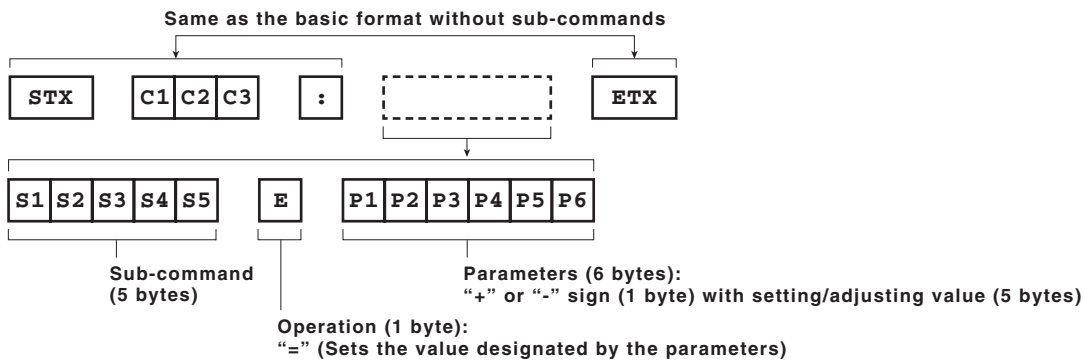

NOTE: When sending sub-commands that require no parameters, operation (E) and parameters are not necessary.

**CAUTION**

- It may not be possible to send or receive commands for about 10 to 60 seconds when the lamp is first turned on. If this occurs, wait for 60 seconds, then try sending or receiving again.
- When sending multiple commands, be sure to wait for at least 0.5 second after receiving a response from the projector before sending the next command.
- Additional time is sometimes required for response due to processing inside the projector. Set the time-out period for command response to 10 seconds or more.

Cable specifications

Projector		PC (DTE)	
1	NC	NC	1
2			2
3			3
4	NC	NC	4
5			5
6	NC	NC	6
7			7
8			8
9	NC	NC	9

Control commands

Command: <Parameter>	Function	Callback: <Parameter>	Parameter value	
			Min	Max
<b>PON</b> *1/*2	Power on (standby mode on)	<b>PON</b>	-	-
<b>POF</b> *1	Power off (standby mode off)	<b>POF</b>	-	-
<b>IIS</b> :<input signal>	Input signal selection	<b>IIS</b> :<input signal>	-	-
<b>ORF</b> *3	YPbPr/RGB signal switching	<b>ORF</b> =1	-	-
<b>VPM</b> :STD	Picture mode: Standard	<b>VPM</b> :STD	-	-
<b>VPM</b> :DYN	Picture mode: Dynamic	<b>VPM</b> :DYN	-	-
<b>VPM</b> :CIN	Picture mode: Cinema	<b>VPM</b> :CIN	-	-
<b>VPM</b> :REA	Picture mode: Real	<b>VPM</b> :REA	-	-
<b>VPM</b> :BBD	Picture mode: Blackboard	<b>VPM</b> :BBD	-	-
<b>VPM</b> :CBD	Picture mode: Colorboard	<b>VPM</b> :CBD	-	-
<b>VPM</b> :IM1	Picture mode: Image 1	<b>VPM</b> :IM1	-	-
<b>VPM</b> :IM2	Picture mode: Image 2	<b>VPM</b> :IM2	-	-
<b>VPM</b> :IM3	Picture mode: Image 3	<b>VPM</b> :IM3	-	-
<b>VPM</b> :IM4	Picture mode: Image 4	<b>VPM</b> :IM4	-	-
<b>AVL</b> :<p1>	Volume control	<b>AVL</b> :<p1>	0	63
<b>AUU</b>	Volume up	<b>AUU</b>	-	-
<b>AUD</b>	Volume down	<b>AUD</b>	-	-

\*1 Do not send PON, or POF commands continuously in a short period of time. Doing so may burst the lamp or shorten the lamp replacement cycle.

\*2 These commands are effective when the standby mode is set to eco. (Other commands are not effective.)

\*3 This command is only enabled when Computer 1 is selected.

If anything other than Computer 1 is selected, first transmit the "IIS:RG1" command, and then transmit this command. Furthermore, RBG is always selected when the "IIS:RG1" command is transmitted.

**Status request commands**

Command	Description	Callback <Parameter>
<b>QPW*</b>	Standby power status	<b>&lt;power condition&gt;</b>
<b>Q\$S*</b>	Lamp status	<b>&lt;lamp condition&gt;</b>
<b>QIN</b>	Input signal status	<b>&lt;input signal&gt;</b>
<b>QPM</b>	Picture mode status	Standard <b>STD</b>
		Dynamic <b>DYN</b>
		Cinema <b>CIN</b>
		Real <b>REA</b>
		Blackboard <b>BBD</b>
		Colorboard <b>CBD</b>
		Image 1 <b>IM1</b>
		Image 2 <b>IM2</b>
	Image 3 <b>IM3</b>	
	Image 4 <b>IM4</b>	
<b>Q\$L</b>	Lamp run time	<b>&lt;acctch&gt;</b>
<b>QAV</b>	Volume adjustment value	<b>&lt;p1&gt;</b>

\* These commands are effective when the standby mode is set to eco. (Other commands are not effective.)

NOTE: If a wrong command is received, the projector will send an ER401 command to the computer.

**Parameter format**

Parameter format	Size (Byte)	Definition
<b>&lt;p1&gt;</b>	3 (1 or 2 bytes also possible when under control)	Decimal without signs: 0 to 999 (000, 001, 002...999) Decimal with signs: -99 to +99 (-99...-01, +00, +01, +02...+99) Callback from the projector is 3 Byte.
<b>&lt;off on&gt;</b>	1	0 = off, 1 = on
<b>&lt;input signal&gt;</b>	3	HD1 = HDMI, RG1 = computer 1, RG2 = computer 2, NWP = network PA1 = memory viewer, MG1 = panasonic application, MV1 = Miracast, VID = video, SVD = S-Video
<b>&lt;power condition&gt;</b>	3	000 = power off (standby mode off), 001 = power on (standby mode on)
<b>&lt;lamp condition&gt;</b>	1	0 = standby, 1 = lamp on under control, 2 = lamp on, 3 = lamp off under control
<b>&lt;acctch&gt;</b>	4	Decimal without signs: 0000–9999 hours

NOTE: If a wrong command is received, the projector will send an ER401 command to the computer.

**Command example**

To set the volume to +30, send the command as shown below.

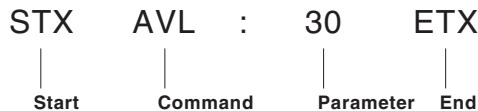

NOTE: When sending commands without parameters, a colon (:) is not necessary.

**Notes on projector placement and operation**

The projector uses a high-wattage lamp that becomes very hot during operation. Please observe the following precautions.

1. Never place objects on top of the projector while it is operating.
2. Make sure there is the unobstructed space as shown below or more around the projector's exhaust openings. In addition to this space, also ensure that there is a sufficient work space for removing and installing the lamp, filter and other parts.
3. Make sure that nothing blocks the projector's air intake and exhaust openings. Also, install the projector so that cool or hot air from other air conditioning equipment does not flow directly toward the projector's air intake or exhaust openings.
4. Do not install the projector in an enclosed space. If it is necessary to install it in an enclosed space, add a separate ventilation system. If ventilation is insufficient, hot air will accumulate at the intake opening. This may cause the projector's protective circuit to interrupt projector operation.

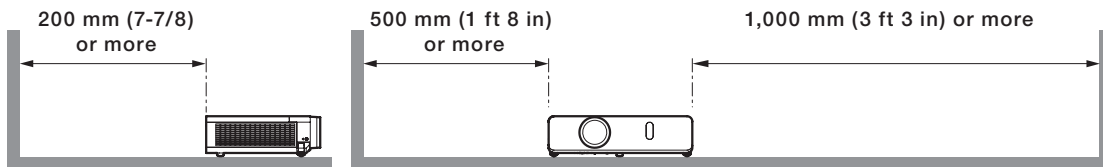

**Direction of air intake and exhaust**

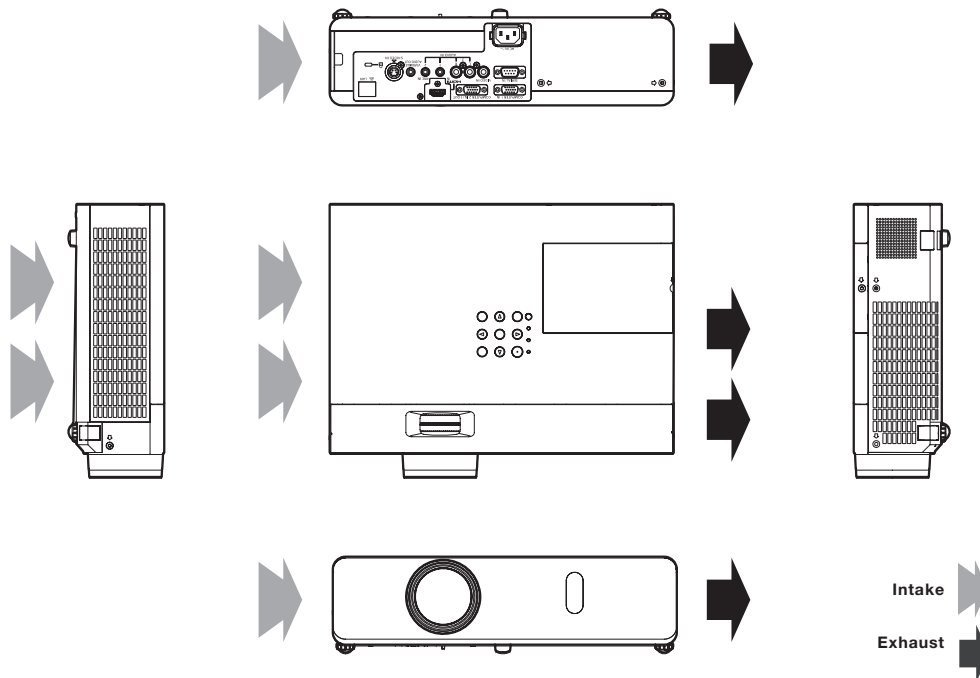

**Operating the projector continuously**

1. If the projector is to be operated continuously 12 hours or more, lamp replacement cycle duration becomes shorter.
2. The lamp replacement cycle duration becomes shorter if the projector is operated repeatedly for short periods (one hour or less).

Weights and dimensions shown are approximate. Specifications and appearance are subject to change without notice.  
Product availability differs depending on region and country. This product may be subject to export control regulations.

Microsoft®, Windows®, Windows Vista® and Internet Explorer® are all registered trademarks of Microsoft Corporation in the United States.  
Apple, Macintosh, Mac, Mac OS and Safari are registered trademarks of Apple Inc. in the United States.

Miracast is a trademark or registered trademark of the Wi-Fi-Alliance.

PJLink is a registered trademark, or a trademark application has been filed, in Japan, the United States, and other countries and regions.  
All other trademarks are the property of their respective trademark owners.