

Description

This bracket assembly is used when mounting a Panasonic's applicable projector to ceilings.

NOTE: This ceiling mount bracket cannot be used by itself. Combine it with the optional ceiling mount bracket.

Specifications

Dimensions (W × H × D):	260 × 54.5 × 346 mm (10-1/4 × 2-5/32 × 13-5/8 inches)
Weight:	Approx. 4.0 kg* (8.8 lbs*)
Applicable ceiling mount bracket:	ET-PKV100H/PKV100S
Applicable projector:	PT-CW230/CX200

* Average value. May differ depending on models.

Parts

Projector mount bracket (bracket assembly)	1	Washer-fitted hexagonal bolts (M6 × 18)	1
Washer-fitted hexagonal bolts (M4 × 10)	6	Safety wire	1
Washer-fitted hexagonal bolts (M4 × 18)	5		

Caution:

- Mounting should be done by a qualified technician.
- Make sure that the mounting (ceiling) area has sufficient strength.
- Read the enclosed mounting instructions thoroughly before starting.
- Do not use an electric screwdriver or impact driver to tighten screws. Use a torque driver or hexagon torque wrench and tighten screws to the torque specified in the instructions.
- When the product is no longer going to be used, have it disposed of quickly by a professional disposal service.

Dimensions

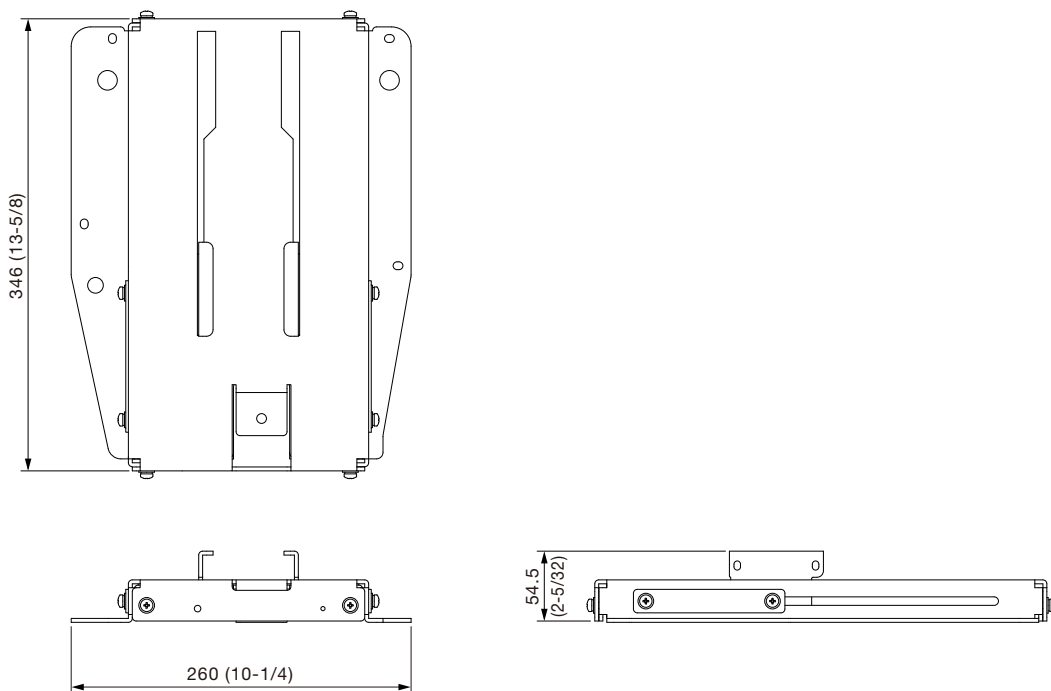

unit : mm (inch)
NOTE: This illustration is not drawn to scale.

Weights and dimensions shown are approximate. Specifications and appearance are subject to change without notice.