

Highly durable filter unit

Description

The highly durable filter unit attaches externally to the PT-LB2 or other projector for use in extremely dusty environments. Using the highly durable filter unit doubles the ordinary cleaning cycle of the air filter.

Specifications	Dimensions (W × H × D):	26.5 × 64 × 202 mm (1-1/16" × 2-17/32" × 7-31/32")
	Weight:	0.1 kg (0.22 lbs)

Note: Height (H) include holding brackets.

Weights and dimensions shown are approximate. Specifications subject to change without notice.

Dimensions

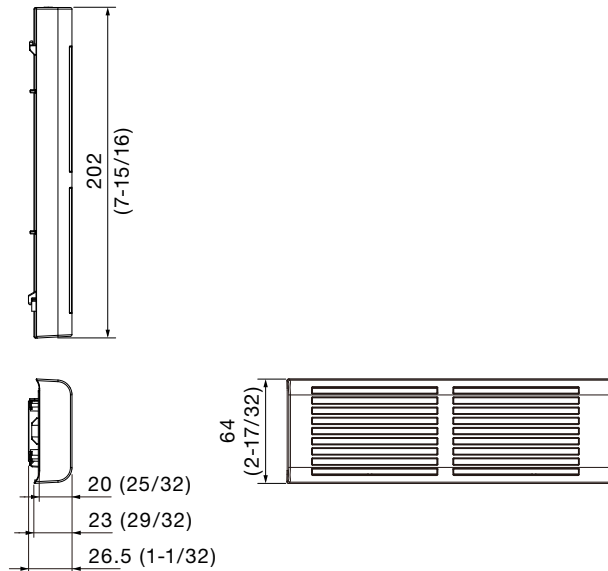
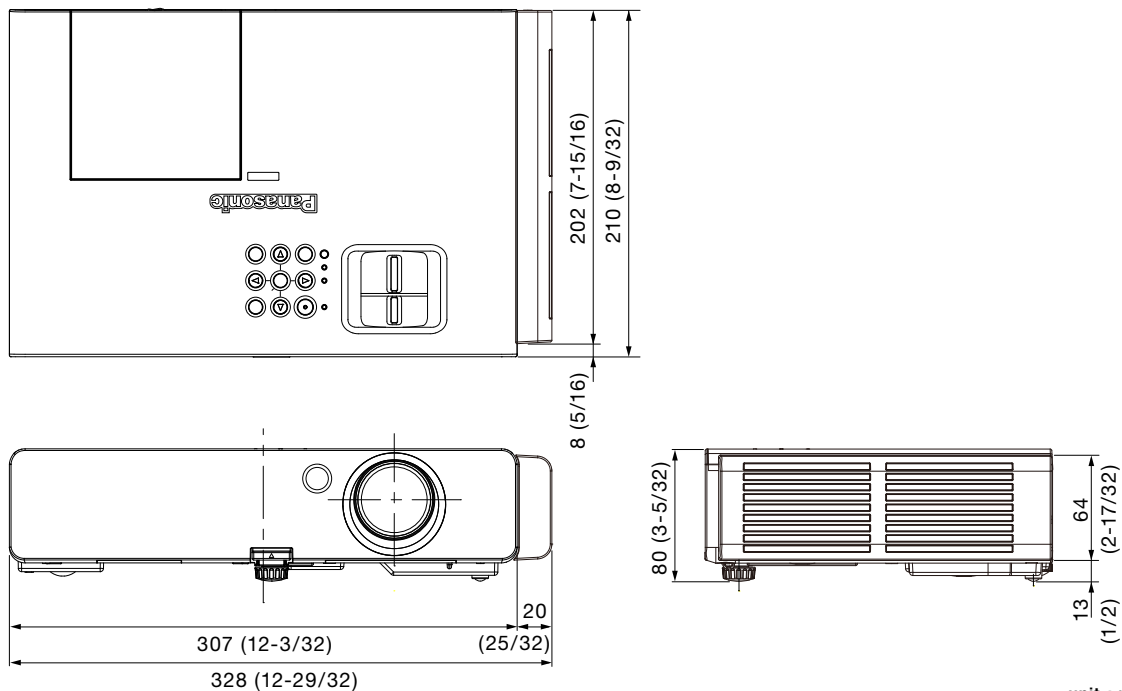

Illustration shows the filter unit attached to the PT-LB2/LB1.



unit : mm (inch)
NOTE: This illustration is not drawn to scale.

Highly durable filter unit

Illustration shows the filter unit attached to the PT-ST10.

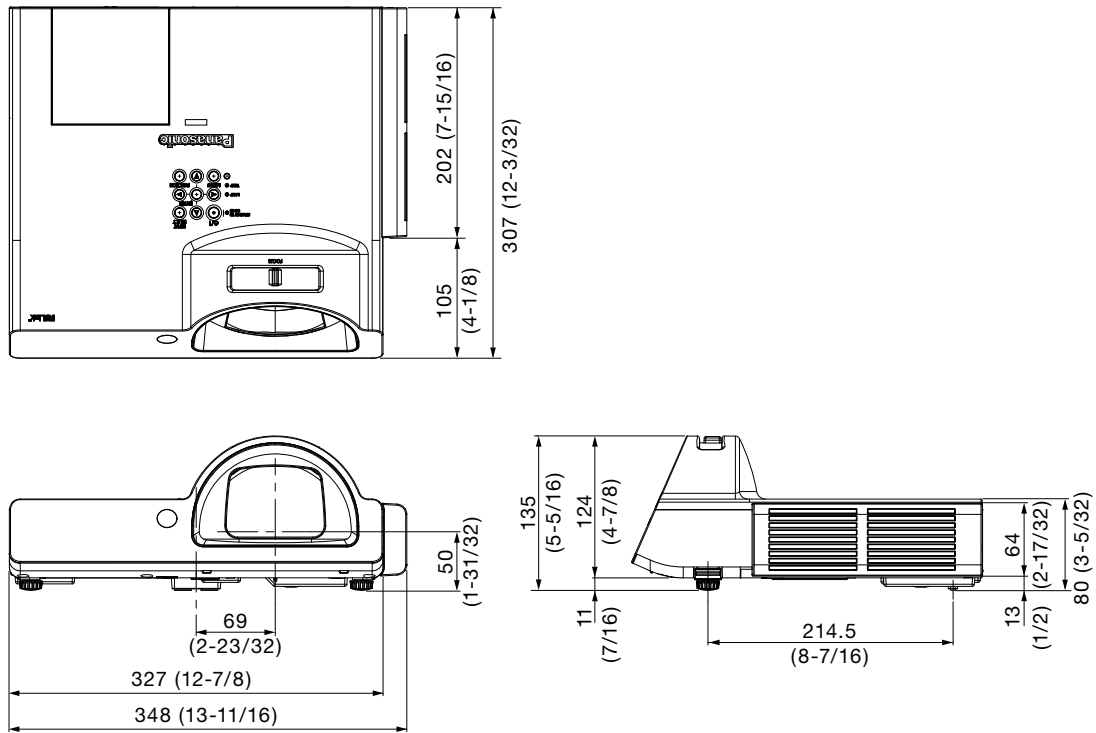

unit : mm (inch)
 NOTE: This illustration is not drawn to scale.