

S P E C F I L E

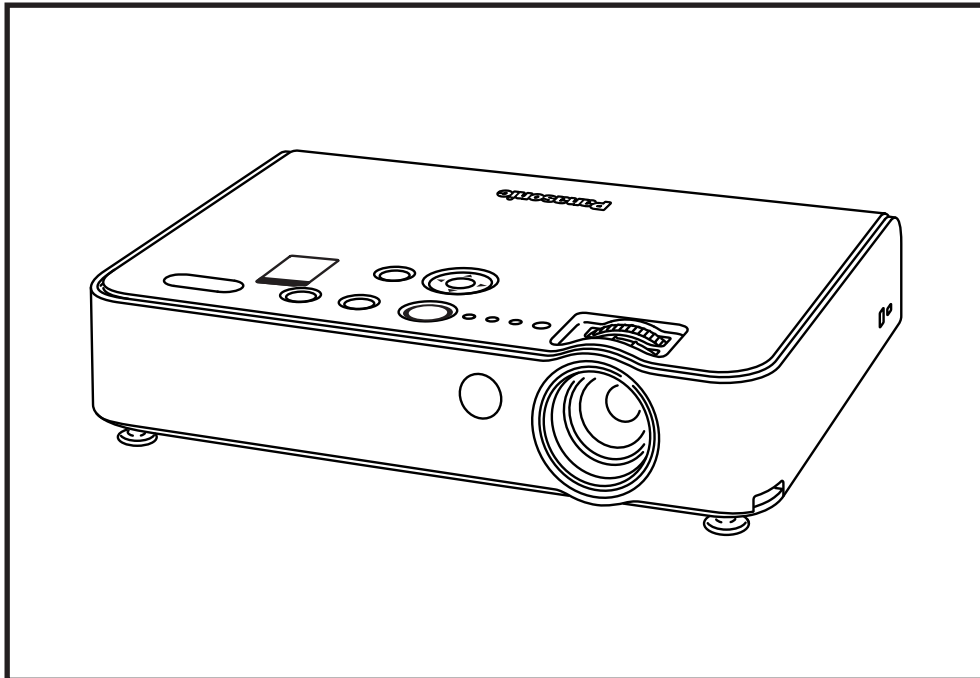

Product Number : **PT-LB51NT**

Product Name : Micro-Portable Wireless LCD Projector

Specifications

Power supply		100–240 V AC, 50/60 Hz
Power consumption		240 W (approx. 4 W in standby mode with fan stopped.)
Optical system		Dichroic mirror separation/prism synthesis system
LCD panel	Panel size	0.6" (15.24 mm) diagonal, micro lens array (4:3 aspect ratio)
	Display method	Transparent LCD panel (x 3, R/G/B)
	Drive method	Active matrix
	Pixels	786,432 (1,024 x 768) x 3, total of 2,359,296 pixels
	Pixel configuration	Stripe
Lens		Manual zoom (1:1–1:1.2), manual focus F 1.6–1.9, f 18.8–22.6 mm
Lamp		165 W UHM lamp
Colors		Full color (16,777,216 colors)
Brightness		2,000 lumens
Center-to-corner uniformity ratio		85%
Contrast ratio		400:1** (full on/full off)
Resolution RGB		1,024 x 768 pixels (Input signals that exceed this resolution will be converted to 1,024 x 768 pixels.)
Scanning frequency	RGB	Horizontal: 15.00–91.00 kHz, Vertical: 50–85 Hz
	YPbPr	480i (525i): fH 15.75 kHz; fV 60 Hz 576i (625i): fH 15.63 kHz; fV 50 Hz 480p (525p): fH 31.50 kHz; fV 60 Hz 576p (625p): fH 31.25 kHz; fV 50 Hz 720/60p (750p): fH 45.00 kHz; fV 60 Hz 1080/60i (1125i): fH 33.75 kHz; fV 60 Hz 1080/50i (1125i): fH 28.13 kHz; fV 50 Hz
	S-Video/Video	NTSC, NTSC4.43, PAL-M, PAL60: fH 15.75 kHz; fV 60 Hz PAL, SECAM, PAL-N: fH 15.63 kHz; fV 50 Hz
Projection size		838–7,620 mm (33–300 inches) diagonally, 4:3 aspect ratio
Throw distance		1.1 m–11.1 m (3'7"–36'5")
Optical axis shift		6:1 (fixed)
Keystone correction range		Vertical: approx. ±30°
On-screen menu		17 languages: English, French, German, Spanish, Italian, Korean, Russian, Chinese, Japanese, Swedish, Norwegian, Danish, Portuguese, Polish, Hungarian, Czech, and Thai
Installation		Front/rear, ceiling/desk (menu selection)
Built-in speakers	Size	4 x 2 cm x 1, oval
	Output power	1.0 W (monaural)
Terminals	COMPUTER (RGB) 1 IN	D-sub HD 15-pin x 1
	RGB signal	R, G, B: 0.7 V _{p-p} , 75 Ω, Sync on green: 1.0 V [p-p], 75 Ω, HD/SYNC, VD: TTL (positive/negative polarity compatible)
	YPbPr signal	Y: 1.0 V [p-p] (including sync signal), 75 Ω, Pb, Pr: 0.7 V _{p-p} , 75 Ω
	COMPUTER (RGB) 2 IN/1 OUT	D-sub HD 15-pin x 1 (input/output selectable using on-screen menu)
	RGB signal	R, G, B: 0.7 V [p-p], 75 Ω, Sync on green: 1.0 V [p-p], 75 Ω, HD/SYNC, VD: TTL (positive/negative polarity compatible)
	YPbPr signal	Y: 1.0 V [p-p] (including sync signal), 75 Ω, Pb, Pr: 0.7 V [p-p], 75 Ω
	VIDEO IN	RCA pin x 1, 1.0 V _{p-p} , 75 Ω
	S-VIDEO IN	Mini DIN 4-pin x 1, Y: 1.0 V [p-p], C: 0.286 V [p-p], 75 Ω
	COMPUTER AUDIO IN	M3 (L, R) x 1, 0.5 V [rms], for COMPUTER (RGB) 1 and 2
	AUDIO IN	RCA (L, R) x 1, 0.5 V [rms], for VIDEO and S-VIDEO
	AUDIO OUT	M3 (L, R) x 1, 0–2.0 V [rms] (variable)
	SERIAL	Mini DIN 8-pin x 1, for external control (RS-232C)
Power cord length		2 m/6.6'
Cabinet material		Moulded plastic (PC + ABS)

Dimensions (W x H x D)		297 x 57 x 210 mm (11-11/16" x 2-7/32" x 8-1/4")*2
Weight		1.9 kg (4.2 lbs.)
Operating environment	Temperature	0°–40°C (32°–104°F)
	Humidity	20%–80% (no condensation)
Remote control unit	Power supply	3 V DC (AA battery x 2)
	Operation range*3	Approx. 15 m (49'3") when operated from directly in front of the signal receptor
Wireless LAN	Dimensions (W x H x D)	48 x 163 x 24.5 mm (1-7/8" x 6-13/32" x 31/32")
	Weight	117 g (4.1 oz) (including batteries)
	Standard	IEEE 802.11b/g (ARIB STD-T66)
	Modulation	
	IEEE 802.11b	Direct sequence spread spectrum (DS-SS) system
	IEEE 802.11g	Orthogonal frequency division multiplex (OFDM) system
	Transmission system	
	IEEE 802.11b	CCK (11/5.5 Mbps), DQPSK (2 Mbps), DBPSK (1 Mbps)
	IEEE 802.11g	64-QAM (54/48 Mbps), 16-QAM (36/24 Mbps), QPSK (18/12 Mbps), BPSK (9/6 Mbps)
	Transmission speed	
IEEE 802.11b	11 Mbps, 5.5 Mbps, 2 Mbps, 1 Mbps	
IEEE 802.11g	54 Mbps, 48 Mbps, 36 Mbps, 24 Mbps, 18 Mbps, 12 Mbps, 9 Mbps, 6 Mbps	
Operating range*2		Approx. 30 m (98'5")
Frequency range		PT-LB51NTE/LB51NTEA: 2,412 MHz–2,472 MHz
		PT-LB51NTU: 2,412 MHz–2,462 MHz
Channels		PT-LB51NTE/LB51NTEA: 1–13 ch
		PT-LB51NTU: 1–11 ch
Supplied accessories		Power cord
		Wireless remote control
		Batteries for remote control
		VGA cable
		Carrying bag
		Wireless Manager ME 4.5 (CD-ROM)
Optional accessories		Replacement lamp unit: ET-LAB50
		Ceiling mount bracket: ET-PKB50
		Serial adapter (DIN 8-pin/D-sub 9-pin): ET-ADSER

*1: In AI mode. *2: Operation range differs depending on environments.

Weights and dimensions shown are approximate. Specifications subject to change without notice.

To use wireless functions, a PC is required that meets the conditions given below:	
OS:	Microsoft® Windows® 2000 Professional, Windows® XP Professional, Windows® XP Home Edition, Windows Vista™ Ultimate 32-bit, Windows Vista™ Business 32-bit, Windows Vista™ Home Premium 32-bit, Windows Vista™ Home Basic 32-bit, Apple Mac OS X 10.4 NOTE: Some functions are not available with Windows Vista™ and Mac OS X.
Web browser:	Windows®: Internet Explorer 6.0 or later, or Netscape Communicator 7.0 or later. Macintosh: Safari 2.0 or later
CPU:	Windows®: Intel® Pentium® III or higher, or other compatible processor (800 MHz or higher is recommended). Macintosh: PowerPC G4 with 800 MHz or more, or Intel® Core™ Duo with 1.8 GHz or more.
Memory:	256 MB or more (Macintosh: 512 MB or more is recommended)
Free hard disk space:	60 MB or more
CD-ROM drive:	CD-ROM drive or DVD drive
Wireless LAN:	IEEE 802.11b/g compatible (built-in wireless LAN system or external IEEE 802.11b/g LAN card must be installed and running normally.) NOTE: Some IEEE 802.11g/b wireless LAN may not allow connection to the projector.

Weights and dimensions shown are approximate. Specifications are subject to change without notice. This product may be subject to export control regulations. Intel and Pentium are registered trademarks of Intel Corporation. Microsoft, Windows Vista and Windows are either registered trademarks or trademarks of Microsoft Corp. in the United States and/or other countries. Apple, Mac, Mac OS, Macintosh and Safari are trademarks of Apple Inc., registered in the U.S. and other countries. All other trademarks are the property of their respective trademark owners. Projection images simulated.

Dimensions

unit : mm (inch)

NOTE: This illustration is not drawn to scale.

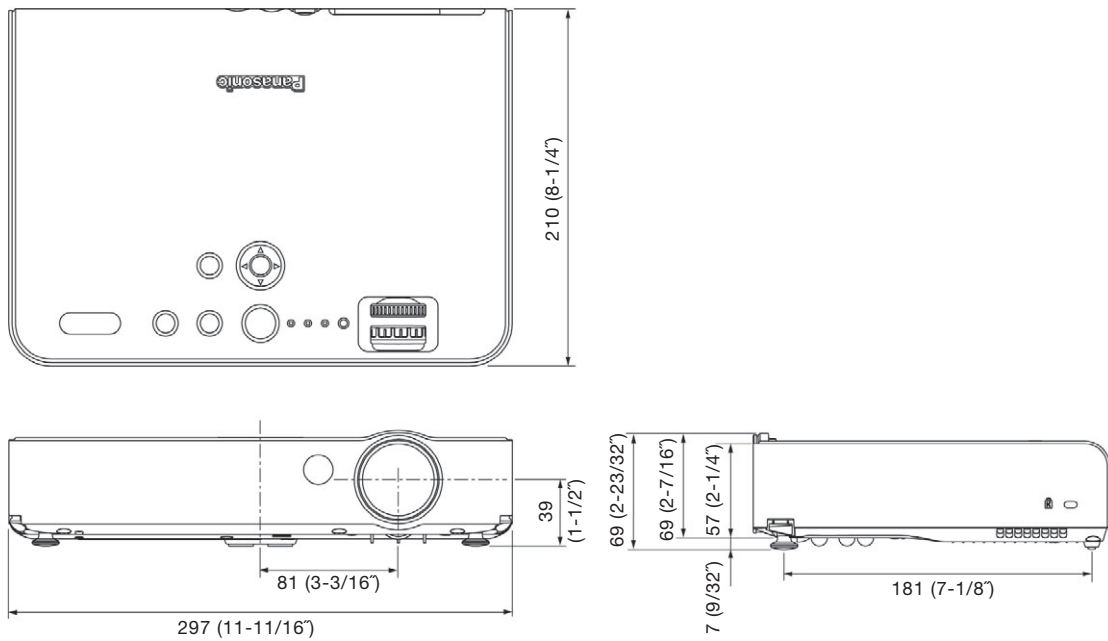

Terminals

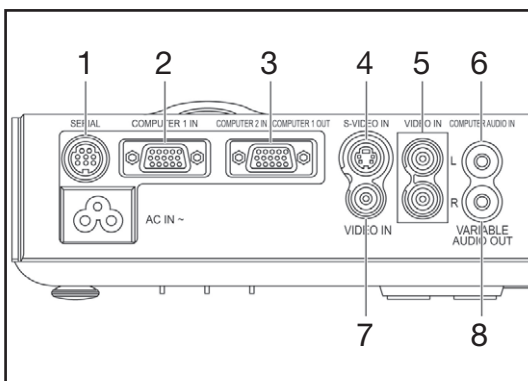

- 1 Serial
- 2 COMPUTER (RGB) 1 input
- 3 COMPUTER (RGB) 2 input/COMPUTER (RGB) 1 output
- 4 S-Video input
- 5 Audio input for Video/S-Video
- 6 Audio input for COMPUTER 1/2
- 7 Video input
- 8 Audio output

Standard setting-up positions

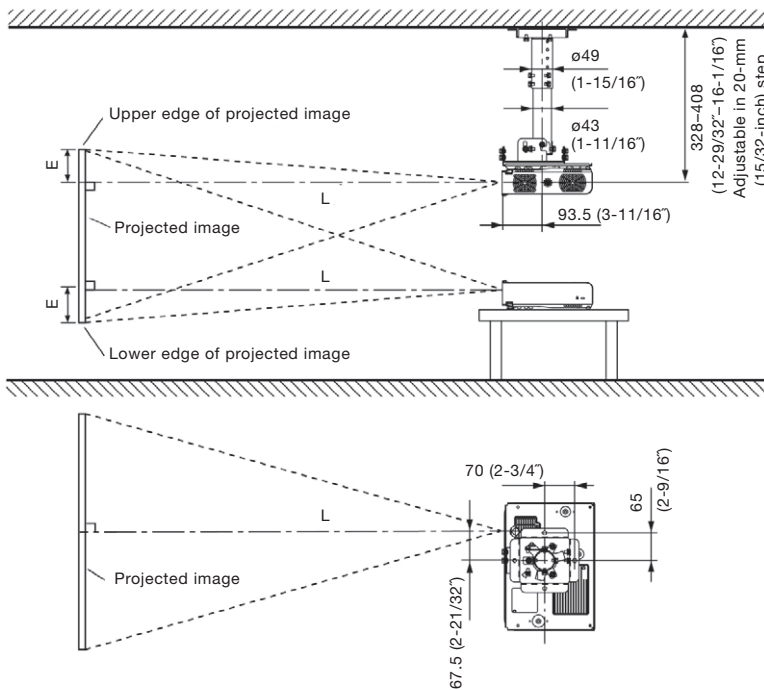

unit : mm (inch)

L: Distance to screen
E: Height from the edge of screen to center of lens

NOTE:
Illustrations show the projector installed using optional ceiling bracket.
This illustration is not drawn to scale.

Projection size (diagonal)	Projection distance (L)		Height from the edge of screen to center of lens (H)
	Min (wide)	Max (telephoto)	
0.84 m / 33"	- / -	1.1 m / 3.9'	0 - 0.07 m / 0 - 0.2'
1.02 m / 40"	1.2 m / 4.0'	1.4 m / 4.7'	0 - 0.09 m / 0 - 0.3'
1.27 m / 50"	1.6 m / 5.0'	1.8 m / 5.9'	0 - 0.11 m / 0 - 0.4'
1.52 m / 60"	1.9 m / 6.0'	2.1 m / 7.2'	0 - 0.13 m / 0 - 0.4'
1.78 m / 70"	2.2 m / 7.0'	2.5 m / 8.4'	0 - 0.15 m / 0 - 0.5'
2.03 m / 80"	2.5 m / 8.0'	2.9 m / 9.6'	0 - 0.17 m / 0 - 0.6'
2.29 m / 90"	2.8 m / 9.0'	3.3 m / 10.8'	0 - 0.19 m / 0 - 0.6'
2.54 m / 100"	3.1 m / 10.0'	3.6 m / 12.0'	0 - 0.21 m / 0 - 0.7'
3.05 m / 120"	3.7 m / 12.0'	4.4 m / 14.5'	0 - 0.25 m / 0 - 0.9'
3.81 m / 150"	4.6 m / 15.1'	5.5 m / 18.1'	0 - 0.32 m / 0 - 1.1'
5.08 m / 200"	6.2 m / 20.1'	7.3 m / 24.2'	0 - 0.42 m / 0 - 1.4'
6.35 m / 250"	7.7 m / 25.1'	9.2 m / 30.3'	0 - 0.53 m / 0 - 1.8'
7.62 m / 300"	9.2 m / 30.2'	11.1 m / 36.4'	0 - 0.64 m / 0 - 2.1'

* This distance is especially recommended for ceiling-mounted use and other permanent installations.

NOTE:
Values shown are approximate.
The value for L (distance to screen) varies slightly depending on the zoom lens characteristics.
When the shortest projection distance is used, a small amount of distortion may occur in the image due to the zoom lens characteristics.

Calculation of the projection distance

For a screen size different from the above, use the equation below to calculate the projection distance.

Aspect ratio 4 : 3

minimum L (m) = (diagonal screen size in inches) x 0.0307 - 0.0310

maximum L (m) = (diagonal screen size in inches) x 0.0371 - 0.0290

Aspect ratio 16 : 9

minimum L (m) = (diagonal screen size in inches) x 0.0335 - 0.0315

maximum L (m) = (diagonal screen size in inches) x 0.0405 - 0.0365

Computer data compatibility

This projector accepts up to 91 kHz horizontal scanning frequency and 162 MHz dot clock.

NOTE: Pixel thinning is applied to signals that exceed a dot clock frequency of 100 MHz. The display resolution of this projector is 1,024 x 768 pixels. Input signals that exceed this resolution will be converted to 1,024 x 768 pixels.

List of compatible signals

Display mode	Display resolution (dots) ¹	Scanning frequency		Dot clock frequency (MHz)	Picture quality ²	Format
		H (kHz)	V (kHz)			
NTSC/NTSC4.43/PAL-M/PAL60	720 x 480i	15.7	59.9	-	A	VIDEO/S-VIDEO
PAL/PAL-N/SECAM	720 x 576i	15.6	50.0	-	A	
525i (480i)	720 x 480i	15.7	59.9	13.5	A	COMPUTER/ COMPONENT
625i (576i)	720 x 576i	15.6	50.0	13.5	A	
525p (480p)	720 x 480	31.5	59.9	27.0	A	
625p (576p)	720 x 576	31.3	50.0	27.0	A	
750 (720)/60p	1,280 x 720	45.0	60.0	74.3	A	
1125 (1080)/60i	1,920 x 1,080i	33.8	60.0	74.3	A	
1125 (1080)/50i		28.1	50.0	74.3	A	
VGA400	640 x 400	31.5	70.1	25.2	A	COMPUTER
		37.9	85.1	31.5	A	
VGA480	640 x 480	31.5	59.9	25.2	A	
		35.0	66.7	30.2	A	
		37.9	72.8	31.5	A	
		37.5	75.0	31.5	A	
		43.3	85.0	36.0	A	
SVGA	800 x 600	35.2	56.3	36.0	A	
		37.9	60.3	40.0	A	
		48.1	72.2	50.0	A	
		46.9	75.0	49.5	A	
		53.7	85.1	56.3	A	
MAC16	832 x 624	49.7	74.6	57.3	A	
XGA	1,024 x 768	48.4	60.0	65.0	AA	
		56.5	70.1	75.0	AA	
		60.0	75.0	78.8	AA	
		68.7	85.0	94.5	AA	
	1,280 x 768i	35.5	87.0	44.9	AA	
MXGA	1,152 x 864	64.0	71.2	94.2	B	
		67.5	74.9	108.0	B	
		76.7	85.0	121.5	B	
MAC21	1,152 x 870	68.7	75.1	100.0	B	
MSXGA	1,280 x 960	60.0	60.0	108.0	B	
SXGA	1,280 x 1,024	64.0	60.0	108.0	B	
		80.0	75.0	135.0	B	
		91.1	85.0	157.5	B	
SXGA+	1,400 x 1,050	64.0	60.0	108.0	B	
		65.1	60.0	122.4	B	
UXGA60	1,440 x 900	75.0	60.0	162.0	B	
WXGA	1,600 x 1,200	47.8	59.9	79.5	A	
		49.7	59.8	83.5	A	
WXGA+	1,440 x 900	55.9	59.9	106.5	A	

1. The “i” appearing after the resolution indicates an interlaced signal.

2. The following symbols are used to indicate picture quality.

AA Maximum picture quality can be obtained.

A Signals are converted by the image processing circuit before picture is projected.

B Signals are compressed by the image processing circuit before picture is projected.

Serial connector

The serial connector complies with RS-232C. To control the projector from a personal computer, commands must be input through communication software, based on the format and satisfying the communication conditions shown below.

CAUTION

Be sure to see that an optional serial adapter ET-ADSER and a RS-232C communication cable match the PC to be connected.

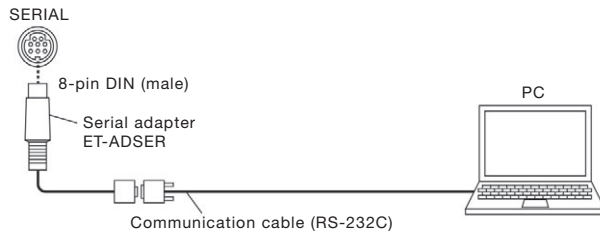

Pin assignments and signal names

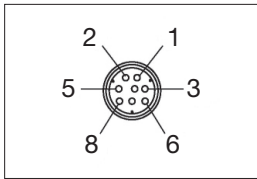

Mini DIN 8-pin

No.	Signal name	Description	No.	Signal name	Description
1	-	Connected internally	5	TXD	Send data
2	-	Connected internally	6	-	Connected internally
3	RXD	Receive data	7	-	NC
4	GND	Ground	8	-	NC

Communication conditions (factory setting)

Signal level	RS-232C-compliant
Synchronization method	Start-stop synchronization
Baud rate	9,600 bps
Parity	None
Character length	8 bits
Stop bit	1 bit
X parameter	None
S parameter	None

Basic format

Transmission from the computer begins with STX, then the ID, command, parameter, and ETX are sent in this order. Add parameters according to the details of control.

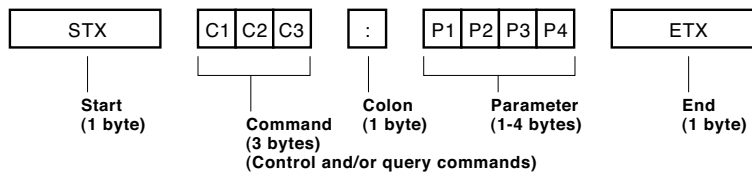

CAUTION

When sending multiple commands, be sure to send the next command after receiving a response from the projector.

Cable specifications

Serial adapter (ET-ADSER)		Projector	PC (DTE)
-	-	1	NC
5	2	2	NC
3	3	3	NC
-	-	4	NC
4	5	5	NC
6	6	6	DSR
1	7	7	NC
2	8	8	NC
-	-	9	NC

Control commands

Command: <Parameter>	Function	Callback: <Parameter>	Parameter value	
			Min	Max
PON*1	Power on (standby mode on)	PON	-	-
POF*1	Power off (standby mode off)	POF	-	-
AVL:<pl>	Volume control	AVL:<pl>	0	63
IIS:<input signal>	Input signal selection	IIS:<input signal>	-	-
OST	The same function as "default" button	OST	-	-
OFZ:<off on>	Freeze	OFZ:<off on>	0	1
OEN	Enter	OEN	-	-
VPM:<picture mode>	Picture mode	VPM:<picture mode>	-	-
:<NAT>	Natural	:<NAT>	-	-
:<STD>	Standard	:<STD>	-	-
:<DYN>>	Dynamic	:<DYN>	-	-
:<BBD>	Blackboard	:<BBD>	-	-
AUU	Volume up	AUU	-	-
AUD	Volume down	AUD	-	-
OMN	Menu	OMN	-	-
OCU	Cursor up	OCU	-	-
OCD	Cursor down	OCD	-	-
OCL	Cursor left	OCL	-	-
OCR	Cursor right	OCR	-	-
OAS	Auto setup	OAS	-	-
OSH*1/*2	Shutter	OSH	-	-
OIX	Index window	OIX	-	-
DZU	Digital zoom: Enlargement	DZU	-	-
DZD	Digital zoom: Reduction	DZD	-	-

*1 Do not send PON, POF, or OSH commands continuously in a short period of time. Doing so may burst the lamp or shorten the lamp replacement cycle.

*2 When a command other than OSH is sent while the shutter function is operating, the projector will send an ER401 command in reply and release the shutter function.

Status asking commands

Command	Description	Callback <Parameter>
QPW	Standby power status	<power condition>
QSS	Lamp status	<lamp condition>
QIN	Input signal status	<input signal>
QAV	Volume adjustment value	<pl>
QVC	Color adjustment value	<pl>
QVT	Tint adjustent value	<pl>
QVB	Brightness adjustment value	<pl>
QVR	Contrast adjustment value	<pl>
QVS	Sharpness adjustment value	<pl>
QWR	White balance: R adjustment value	<pl>
QWG	White balance: G adjustment value	<pl>
QWB	White balance: B adjustment value	<pl>
QHP	Horizontal position adjustment value	<pl>
QVP	Vertical position adjustment value	<pl>
QCP	Clock phase adjustment value	<pl>
QDC	Dot clock adjustment value	<pl>
QSP	Installation setting status	<pl>
QLG	On-screen menu language	<pl>
QPM	Picture mode status	Natural <NAT>
		Standard <STD>
		Dynamic <DYN>
		Blackboard <BBD>
QFZ	Freeze status	<off on>
QSL	Lamp run time	<acctch>
QSH	Shutter function status	<off/on>
QKS	Keystone correction status	<pl>
QTE	Color temperature adjustment status	<color temp>

Parameter format

Parameter format	Size (Byte)	Difinition
<pl>	3 (1 or 2 bytes also possible when under control)	Dicimal without signs: 0-999 (000, 001, 002...999) Dicimal with signs: -99 to +99 (-99...-01, +00, +01, +02...+99) Callback from the projector is 3 Byte.
<off on>	1	0 = off, 1 = on
<input signal>	3	RG1 = computer 1, RG2 = computer 2, NWP = network, VID = video, SVD = S-Video
<installation>	1	0 = front, 1 = rear, 2 = ceiling and front, 3 = ceiling and rear
<language>	3	ENG = English, DEU = German, FRA = French, ESP = Spanish, ITL = Italian, JPN = Japanese, CHI = Chinese, POR = Portuguese, SVE = Swedish, NOR = Norwegian, DAN = Danish, POL = Polish, CES = Czech, MAG = Hungarian, RUS = Russian, THA = Thai, KOR = Korean
<power condition>	3	000 = power on (standby mode on), 001 = power off (standby mode off)
<lamp condition>	1	0 = standby, 1 = lamp on under control, 2 = lamp off, 3 = lamp off under control
<acctch>	4	Dicimal without signs: 0000-9999 hours
<lamp power>	1	0 = economy, 1 = normal
<color temp>	1	0 = low, 1 = standard, 2 = high

NOTE: If a wrong command is received, the projector will send an ER401 command to the computer.

Command example

To set the volume to +30, send the command as shown below.



NOTE: When sending commands without parameters, a colon (:) is not necessary.

Notes on Projector Placement and Operation:

The projector uses a high-wattage lamp that becomes very hot during operation. Please observe the following precautions.

1. Never place objects on top of the projector while it is operating.
2. Make sure there is an unobstructed space of 150 mm (5-29/32") or more around the projector's exhaust openings.
3. If the projector is placed in a box or enclosure, ensure the temperature of the air surrounding the projector is between 0°C/32°F and 35°C/95°F. Also make sure the projector's intake and exhaust openings are not blocked. Take particular care to ensure that hot air from the exhaust openings is not sucked into the intake openings.

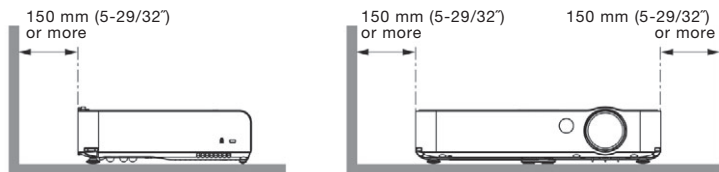

Direction of Air Intake and Exhaust

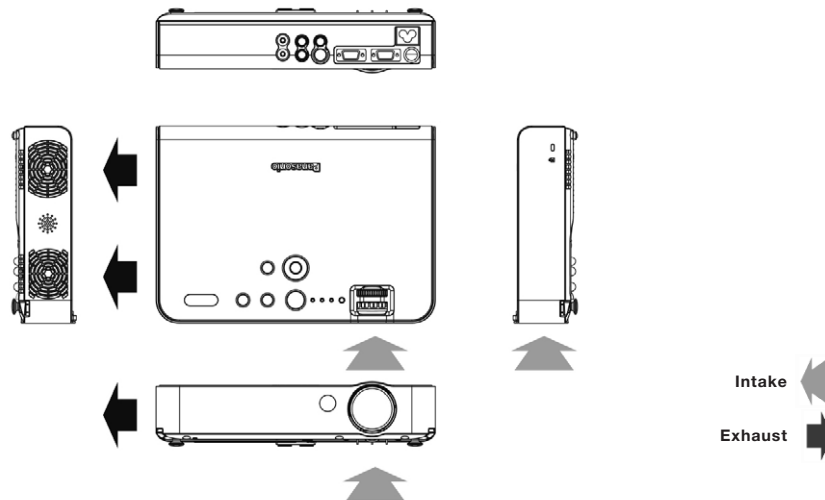

Operating the Projector Continuously

1. If the projector is to be operated continuously 10 hours or more, lamp replacement cycle duration becomes shorter.
2. The lamp replacement cycle duration becomes shorter if the projector is operated repeatedly for short periods.

Weights and dimensions shown are approximate. Specifications are subject to change without notice. This product may be subject to export control regulations. Intel and Pentium are registered trademarks of Intel Corporation. Microsoft, Windows Vista and Windows are either registered trademarks or trademarks of Microsoft Corp. in the United States and/or other countries. Apple, Mac, Mac OS, Macintosh and Safari are trademarks of Apple Inc., registered in the U.S. and other countries. All other trademarks are the property of their respective trademark owners. Projection images simulated.