

# Panasonic

ideas for life

PT-DW7000E/E-K  
3-Chip WXGA DLP™ Projector

## Native 16:9 Wide-Screen Impact



PT-DW7000E-K





**16:9 Wide Panels**  
**4,000 : 1 Contrast Ratio**

## Bright, Vivid Images that Deliver All the Emotion and Excitement

Only a projector that offers superior brightness and contrast can give you vivid, faithful reproduction of images that have both light and dark areas, such as a starship in outer space or a face partly cloaked in shadow.

A projector like Panasonic's PT-DW7000E series.

The PT-DW7000E series combines outstanding 6,000-lumen brightness with 4,000:1 contrast\*. Also featuring Texas Instruments DLP™ technology and unique 16:9 wide-aspect panels (1,366 x 768), this 3-chip DLP™ projector truly excels in the projection of various sources.

The PT-DW7000E series also adds features such as Dynamic Iris, which improves contrast by matching the lamp output to the input signal. The liquid-cooled optical engine boosts both reliability and durability while greatly reducing operating noise.

The PT-DW7000E series is suitable for a wide variety of applications, from boardrooms, conference rooms, and post-production to broadcasting.

\* With the Dynamic Iris set to 3.



### Dynamic Iris: Deeper Blacks, Brighter Whites, and Vivid, True-to-Life Colour

Incorporating Panasonic exclusive technology, the Dynamic Iris opens and closes with exceptional speed and precision as the input signal changes, resulting in accurate, real-time control of the light striking the DLP™ chips. The Dynamic Iris is positioned immediately after the light synthesiser and before the integrator, so it has minimal adverse effect on the overall light uniformity across the screen.

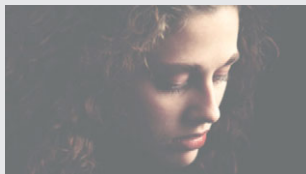

#### Competitor A

Blacks and other dark portions are washed out.

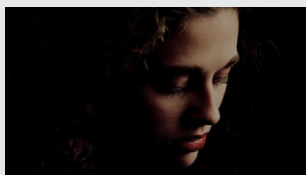

#### Competitor B

Thanks to functions such as lamp power switching, the blacks are not washed out. The white portions, however, become dim and dull.

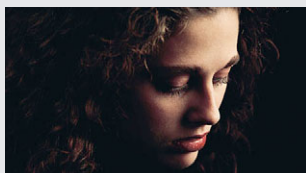

#### Dynamic Iris and Dynamic Gamma

Dynamic Iris quickly fine-tunes the lamp output with 256-step precision. Dynamic Gamma preserves the brightness in bright portions, helping maintain a wide dynamic range.

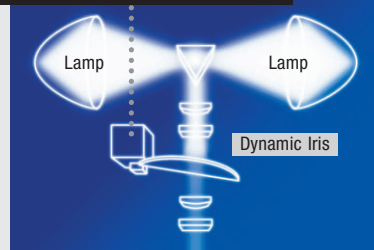
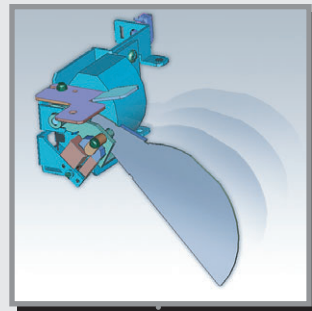





## 3-Chip DLP™ Technology in a Sleek, Compact Body

### A Light, Compact, 3-Chip Large-Venue DLP™ Projector

The PT-DW7000E series combines a 3-chip system based on DLP™ technology with a high-precision optical system developed using our exclusive technology. We have dramatically reduced the cabinet size, creating a unit with only one-fifth the volume of conventional large-venue 3-chip DLP™ projectors. With a weight of 22.0 kg (48.5 pounds), the PT-DW7000E/E-K can go places other bulky 3-chip projectors with DLP™ technology have never gone before.



## Superb Image Quality

### Native 16:9 Panels

The PT-DW7000 is the world's first 3-chip DLP™ installation projector with 16:9 wide aspect panels. Unique to Panasonic, these panels let the PT-DW7000E/E-K project wide-screen images without sacrificing the superior image quality provided by DLP™ technology. They also fit more information onto a PC screen.

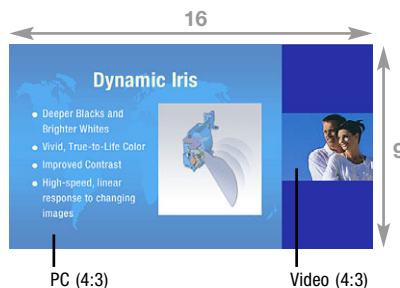

Picture in Picture images also fit more easily onto the screen.

### Image Quality from 3-Chip DLP™ Technology

DLP™ technology delivers outstanding image resolution. In 3-chip systems with DLP™ technology—considered among the world's most advanced projector engines—a DLP™ chip is allocated to each of the red, green, and blue signals. This gives systems with DLP™ technology superior light utilisation for high brightness, digital processing for low noise and linear white balance, extended device life for minimal image degradation, and a quick response that eliminates afterimages.

### Powerful 6,000 Lumens

In addition to the 300-watt UHM™ lamp, the PT-DW7000E series incorporates digital and optical technologies that maximise the DLP™ technology advantages. They deliver 6,000 Lumens of brightness, offering superior colour reproducibility.

### Astounding 4,000:1 Contrast Ratio with Dynamic Iris

Panasonic's original Dynamic Iris achieves a dramatically improved contrast ratio of 4,000:1 in the PT-DW7000E series. Dynamic Iris constantly monitors the input signal, and adjusts the intensity of the light source to match it. This highly advanced function provides high-speed, linear response to changing images with 256-step precision. It also combines with dynamic gamma control to produce deep, rich blacks while preserving the brightness in the lighter portions of dark scenes.

### 16-Bit Colour Depth for Film-Like Natural Image

Applying 16-bit drive to each of the RGB panels produces 8 times the level of expression (a total of 24 times for all three RGB panels) of conventional 13-bit drive devices. This system creates extremely smooth tonal expression with approx. 65,000 shades of gradation.

### Progressive Cinema Scan (3/2 Pulldown)

This interlace/progressive conversion technology automatically detects when the input signal is derived from filmed material and selects the optimum progressive processing method to assure faithful reproduction of the original image. It is also compatible with the high-definition 1080i format.

### Dynamic Sharpness Control

The Dynamic Sharpness Control circuit adjusts the video signal waveforms based on the difference in the brightness of adjacent pixels for a sharp, clear picture that is relatively unaffected by signal noise.

## High Reliability and Easy Maintenance

### Liquid-Cooling System

In systems with DLP™ technology, the microscopic mirrors of the DLP™ chip turn the light on and off. During the off period, light is directed away from the lens. Handling the heat from this light is a major point in maintaining the long-term performance of projectors with DLP™ technology.

Panasonic's newly developed liquid-cooling system extends projector performance and attains a high level of reliability.

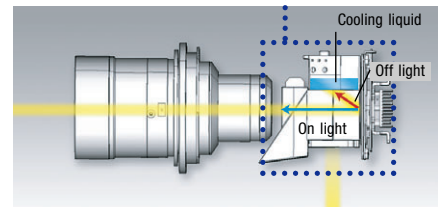

### Dust-Resistant Optical Block

The dust-resistant design of the optical block helps ensure that 3-chip projectors with DLP™ technology will continue to deliver crisp, sharp, high-resolution images over an extended service life.

### Dual Lamp System and Lamp Relay Function

The use of two lamp systems increases brightness and eliminates the need to interrupt a presentation if a lamp burns out (in dual lamp operation mode). In single lamp operation mode, the lamp relay function greatly extends continuous operating time.

### Optional Long-Life Lamp

A long-life lamp that stretches lamp life to 4,000 hours is available as an option. In single lamp operation mode, the lamp relay function allows non-stop operation 24 hours a day for up to 47 weeks without replacing the lamps. The use of UHM™ lamps dramatically cuts operating costs.

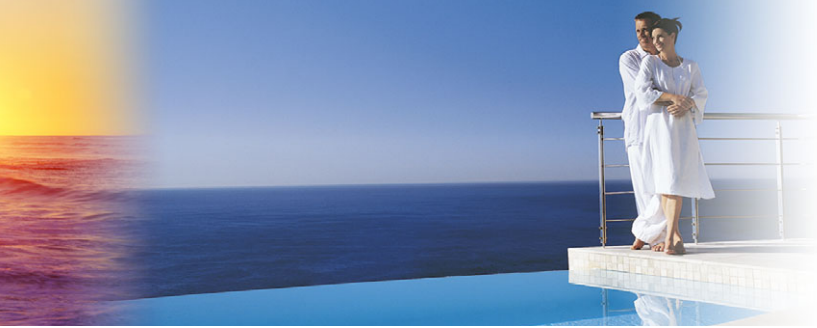

### Easy Lamp Replacement

The PT-DW7000E series is designed to allow easy lamp replacement with the projector in its fully mounted condition. The lamp itself is the only part that needs to be replaced, which further increases overall reliability.

### Dust Filter Cleaning

The dust filter is easy to clean, and you don't have to make any changes in the projector's mounting condition. This helps to minimise user down time.

## Flexible System Applications

### Horizontal/Vertical Lens Shift

The PT-DW7000E series is equipped with a motor-driven lens shifting function that moves the lens left, right, up, and down. It gives you easy, accurate adjustment when installing the projector.

### Optional Lenses for Various Venues

A wide range of optional lenses with different throw distances are available. An optional lens with super-long focal lengths (throw ratio of 8.2 to 15.4) is ideal for use in churches or screening rooms. These powered zoom/focus lenses enable the projectors to perform superbly in an array of projection environments, from classrooms to conference rooms. It's a snap to replace the "click-in" type lenses used in the bayonet system of the PT-DW7000E series.

### Connection Terminals

The PT-DW7000E/E-K features two RGB inputs, a composite video input and output, and an S-Video input. They also offer RS-232C/422 input and output, two remote inputs, and one remote output.



Connection terminals

An optional board module can be added for more connection flexibility.

### Abundant Optional Interface Boards

In addition to the supplied connection terminals, an optional board module can be selected from a total of four boards to match a variety of input source signals, including digital serial component signals.

### Quiet Operation

The PT-DW7000E series is designed for quiet operation. A newly developed liquid-cooled optical system and noise-suppression duct and control system help minimise operating noise. The fan rotation can now be adjusted in finer steps, so fan noise is reduced when rotation adjusts to match room temperature changes. This helps minimise sudden increases in fan noise during operation.

### Built-In Multi-Screen Processor, Colour Matching and Edge Blending

#### MULTI-SCREEN PROCESSOR

The PT-DW7000E/E-K can project large, multi-screen images without any additional equipment. Up to 100 units (10 x 10) can be edge-blended at a time.

#### COLOUR MATCHING

When several units are used together, this function corrects for slight variations in the colour reproduction range of individual projectors. The PC software assures easy, accurate control. Independent, 7-axis adjustment (red, green, blue, yellow, magenta, cyan, white) ensures high precision and minimises colour variations. To simplify the set-up process, you can adjust the projectors before delivering them to the presentation site. The colour-matching function accommodates up to nine units, for multi-screen or single screen presentation.

#### EDGE BLENDING

This function controls the brightness at overlapping image edges to assure uniform, natural-looking, multi-screen images. When projecting HD sources with a single projector, part of the DMD is unused. In multi-screen projections with two projectors, the DMDs increase the image's horizontal resolution while maximising vertical resolution.

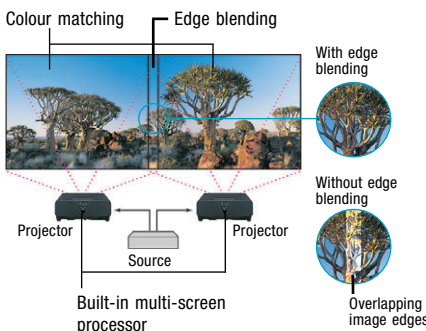

The built-in multi-screen processor enables enlarged multi-screen projection without using any additional special equipment. Colour matching and edge blending make it easier to obtain proper multi-screen picture quality.

## Networking (Optional)

### Wired LAN System

The optional interface board ET-MD75NT for 10Base-T and 100Base-TX makes the PT-DW7000E series network-ready. Simply hook the projector up to an existing LAN network for easy remote control and/or monitoring. System administrators will appreciate this feature when using the PT-DW7000E/E-K as a fixed-installation projector.

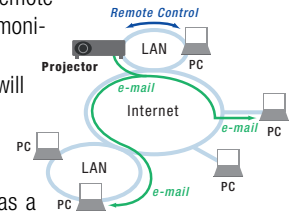

### Web Browser Control/Monitoring

Anybody can operate the PT-DW7000E series by remote control or monitor its status over a LAN network, because it is all done using the computer's familiar Web browser.

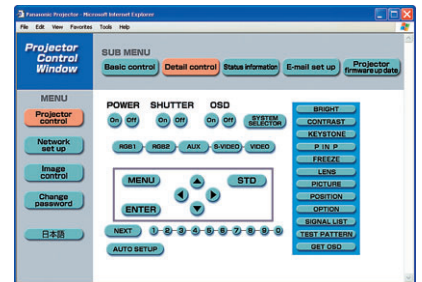

### E-Mail Message Alert

The PT-DW7000E series automatically sends an e-mail message to notify the operator when an error has occurred, or a lamp needs to be replaced, providing an advanced level of maintenance ease and reliability.

### Controlling and Monitoring Multiple Projectors



Panasonic's original "Multi Projector Monitor & Control" freeware allows the user to control and monitor multiple projectors via LAN. When a problem occurs, an alarm message is sent to the controlling/monitoring PC.

\* Available in June 2008. Please consult a sales representative if necessary.

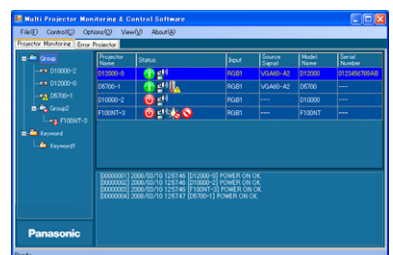

## More Valuable Features

- Mechanical shutter completely blocks light leakage when no image is being projected
- Momentary switching for RGB/Video input without disrupting the image
- 96 user memories
- Wireless/wired remote control unit with wireless mouse function\*
- ID assignment for up to 64 units
- Coordinated group control for up to 26 groups (A-Z)
- Picture in picture (main/sub input)



Wireless/wired remote control

source combinations possible only when using computer and video)

- Digital vertical keystone correction
- 3x digital zoom
- Built-in test pattern
- Selectable 9-language on-screen menu (English, German, French, Spanish, Italian, Russian, Japanese, Chinese, Korean)
- Fan control for high elevations (above 1,400 m/4,600 feet)

\* Requires the optional ET-RMRC2 wireless mouse receiver



Available in black (PT-DW7000E-K) and white (PT-DW7000E) cabinet colours.



### Ecology-Conscious Design

Panasonic works from every angle to minimise environmental impact in the product design, production and delivery processes, and in the performance of the product itself over its life cycle. The PT-DW7000E Series reflects the following ecological considerations.

- Lead-free solder is used to mount components to the printed circuit boards.
- Lead-free glass is used for the lens.
- Lamp power switching further reduces power consumption.

## Options for More Flexible Installation

### Lenses



ET-D75LE1

1.0–1.2:1 Zoom Lens  
ET-D75LE6

1.5–2.0:1 Zoom Lens  
ET-D75LE1

2.1–3.1:1 Zoom Lens  
ET-D75LE2

3.1–5.2:1 Zoom Lens  
ET-D75LE3

5.2–8.2:1 Zoom Lens  
ET-D75LE4

8.2–15.4:1 Zoom Lens  
ET-D75LE8

0.8:1 Fixed-Focus Short-Throw Lens  
ET-D75LE5

### Boards



**Network Board**  
ET-MD77NT

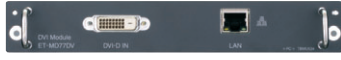

**DVI-D/Network Board**  
ET-MD77DV



**SD-SDI/Network Board**  
ET-MD77SD1

- 480i, 576i



**HD-SDI/SD-SDI/Network Board**  
ET-MD77SD3

- 480i, 576i, 720/60p, 720/50p, 1035/60i, 1080/60i, 1080/50i, 1080/25p, 1080/24p, 1080/24sF, 1080/30p



### Lamps

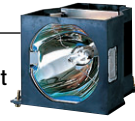

**Replacement Lamp Unit**  
ET-LAD7700

**Replacement Lamp Units**  
(Twin pack of ET-LAD7700 lamp units)  
ET-LAD7700W

**Replacement Long-Life Lamp Unit**  
ET-LAD7700L

**Replacement Long-Life Lamp Units**  
(Twin pack of ET-LAD7700L lamp units)  
ET-LAD7700LW

### Receiver

**Wireless Mouse Receiver**  
ET-RMRC2



### Handle

**Carrying Handle**  
ET-HAD75



### Brackets

**Ceiling Mount Bracket**  
ET-PKD77H



**Low Ceiling Mount Bracket**  
ET-PKD75S



**Dual Stacking Mount Bracket**  
ET-DFD75



## Projection Distance

Diagonal image size (aspect ratio: 16:9)	Distance to screen													
	ET-D75LE6 1.0–1.2:1		ET-D75LE1 1.5–2.0:1		ET-D75LE2 2.1–3.1:1		ET-D75LE3 3.1–5.2:1		ET-D75LE4 5.2–8.2:1		ET-D75LE8 8.2–15.4:1		ET-D75LE5 0.8:1 fixed	
	min.	max.	min.	max.	min.	max.	min.	max.	min.	max.	min.	max.	min.	max.
70"	1.8 5.8	1.6 5.1	1.9 6.1	2.3 7.6	3.1 10.1	3.1 10.3	4.7 15.5	4.7 15.5	7.9 26.0	7.9 26.0	12.7 41.7	12.4 40.7	23.7 77.8	1.2 3.8
100"	2.5 8.3	2.3 7.4	2.7 8.9	3.4 11.0	4.5 14.8	4.5 14.8	6.8 22.3	6.8 22.3	11.4 37.4	11.4 37.4	18.2 59.7	17.9 58.7	33.9 111.2	1.7 5.5
200"	5.1 16.7	4.6 15.0	5.5 17.9	6.8 22.2	9.1 29.7	9.1 29.7	13.7 44.9	13.7 44.9	22.9 75.1	22.9 75.1	36.5 119.8	36.2 118.8	68.3 224.1	3.5 11.3
300"	7.6 25.0	6.9 22.6	8.2 27.0	10.2 33.5	13.6 44.7	13.7 45.0	20.6 67.5	20.6 67.5	34.4 112.9	34.4 112.9	54.8 179.9	54.5 178.8	102.6 336.6	5.2 17.1
400"	10.2 33.3	9.2 30.2	11.0 36.1	13.6 44.7	18.3 60.0	18.3 60.0	27.5 90.1	27.5 90.1	45.9 150.7	45.9 150.7	73.1 239.9	72.9 239.2	136.9 449.1	– –
600"	15.2 50.0	13.8 45.3	16.5 54.3	20.5 67.1	27.4 89.8	27.5 90.2	41.3 135.3	41.3 135.3	68.9 226.2	68.9 226.2	109.7 360.0	109.5 359.3	205.5 674.2	– –

meters  
feet

## Projection Range Example

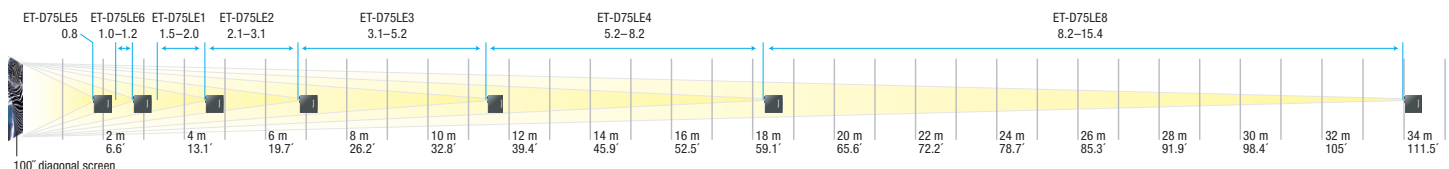



## Specifications

<b>System Device Pixels Lamp</b>	DLP™ projection system 0.85" (diagonal) DLP™ chip (x 3), 16:9 1,049,088 (1,366 x 768) x 3 300 W UHM lamp x 2 (BriteOptic™ Dual Lamp System)
<b>Brightness*1</b>	6000 lumens (dual lamp) 3000 lumens (single lamp)
<b>Contrast ratio*1</b>	4000:1 (full white/full black, with dynamic iris set to "3")
<b>Resolution</b>	1366 x 768 pixels*2
<b>Lens</b>	Optional
<b>Screen size</b>	70"–600" diagonal (70"–300" diagonal, 16:9 aspect ratio with the ET-D75LE5)
<b>RGB input scanning frequency</b>	fH 15–100 kHz, fV 24–120 Hz, Dot clock 20–162 MHz
<b>Component signal</b>	480i, 576i, 480p, 576p, 720/60p, 1035/60i, 1080/60i, 1080/50i, 1080/25p, 1080/24p, 1080/24sF, 1080/30p
<b>Video signal</b>	NTSC, PAL, SECAM, M-NTSC, PAL60, PAL-M, PAL-N
<b>Terminals</b>	
<b>VIDEO IN</b>	BNC
<b>VIDEO OUT</b>	BNC
<b>S-Video IN</b>	Mini DIN 4-pin
<b>RGB1/Y/PbPr IN</b>	BNC x 5
<b>RGB2 IN</b>	D-sub HD 15-pin
<b>Optional board slot x 1</b>	
<b>RS-232C/422 IN</b>	D-sub 9-pin female
<b>RS-232C/422 OUT</b>	D-sub 9-pin male
<b>REMOTE 1 IN</b>	M3 jack
<b>REMOTE 1 OUT</b>	M3 jack
<b>REMOTE 2 IN</b>	D-sub 9-pin female (parallel)
<b>REMOTE 2 OUT</b>	D-sub 9-pin female (parallel)
<b>Lens shift*3</b>	Powered; horizontal ±30%*4, vertical ±70%*4
<b>Keystone correction range</b>	±40° with ET-D75LE2 ±19° with ET-D75LE5 ±28° with ET-D75LE6
<b>Installation</b>	Front/rear, ceiling/floor (menu selec- tion)
<b>Power cord length</b>	2.5 m (8.2')
<b>Power supply</b>	220–240 V AC, 50/60 Hz
<b>Power consumption</b>	800 W (800 VA) (15 W during standby mode with fan stopped)
<b>Dimensions (W x H x D)</b>	530 x 200 x 540 mm (20-7/8" x 7-7/8" x 21-9/32") (without lens and lens hood)
<b>Weight*5</b>	Approx. 22.0 kg/48.5 lbs (without lens)
<b>Operating temperature</b>	0°–40°C (32°–104°F) 0°–35°C (32°–95°F) (dual lamp, lamp power: high)
<b>Operating humidity</b>	10%–80% (no condensation)

- 1: Measurement, measuring conditions, and method of notation all comply with ISO 21118 international standards.  
2: Input signals that exceed this resolution will be converted to 1,366 x 768 pixels.  
3: Shift range is limited during simultaneous horizontal and vertical shifting.  
4: Vertical ±60% with the ET-D75LE6.  
5: Average value. May differ depending on models.

## Supplied accessories

- Wireless/wired remote control unit
- Batteries for remote control unit (R6/LR6 type x 2)
- Remote control cable
- Power cord

## Optional accessories

- Replacement lamp unit (single): ET-LAD7700
- Replacement lamp unit (set of two lamps): ET-LAD7700W
- Replacement long-life lamp unit (single): ET-LAD7700L
- Replacement long-life lamp unit (set of two lamps): ET-LAD7700LW
- Ceiling mount bracket: ET-PKD77H
- Low ceiling mount bracket: ET-PKD75S
- Dual stacking mount bracket: ET-DFD75
- Carrying handle: ET-HAD75
- Zoom lens (1.0–1.2:1): ET-D75LE6
- Zoom lens (1.5–2.0:1): ET-D75LE1
- Zoom lens (2.1–3.1:1): ET-D75LE2
- Zoom lens (3.1–5.2:1): ET-D75LE3
- Zoom lens (5.2–8.2:1): ET-D75LE4
- Zoom lens (8.2–15.4:1): ET-D75LE8
- Fixed focus lens (0.8:1): ET-D75LE5
- Network board: ET-MD77NT
- DVI-D/network board: ET-MD77DV
- SD-SDI/network board: ET-MD77SD1 (480i, 576i)
- HD-SDI/SD-SDI/network board: ET-MD77SD3 (480i, 576i, 720/60p, 720/50p, 1035/60i, 1080/60i, 1080/50i, 1080/25p, 1080/24p, 1080/24sF, 1080/30p)
- Wireless mouse receiver: ET-RMRC2

## Lamp mode/brightness

No. of lamp	Lamp power	Brightness	
		Normal lamp	Long-life lamp
Dual	High	6,000 lm	–
	Low	4,800 lm	3,000 lm
Single	High	3,000 lm	–
	Low	2,400 lm	1,500 lm

## Lamp mode/lamp life

Lamp mode	Lamp life	
	Normal lamp	Long-life lamp
High	1,500 hr	–
Low	2,000 hr	4,000 hr

## NOTE

- The above value is the maximum lifetime when all two lamps are replaced simultaneously, and used in operating cycles of 3.5 hours on and 0.5 hour off. If the ON/OFF frequency increases, the lamp replacement cycle will be shortened. (It is recommended that the mechanical shutter be used to turn off the image for short periods.)
- Using the long-life lamps, lamp life is 8,000 hours maximum when operated in single lamp mode with the lamp relay function on.
- Lamp life varies depending on usage conditions and the surrounding environment.
- When the long-life lamps are used the lamp power mode is automatically set to low.

## Dimensions

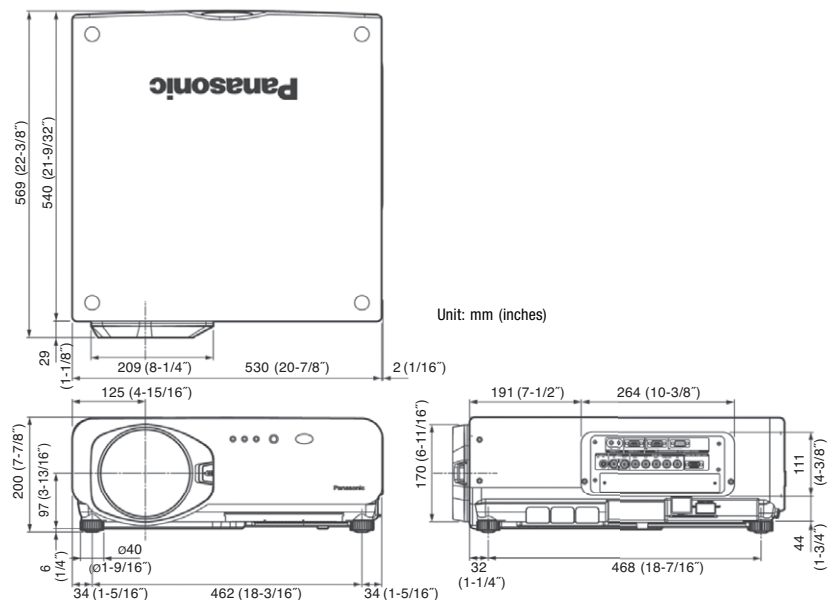

## NOTES ON USE

- Do not install the projector in locations that are subject to excessive water, humidity, steam, or oily smoke. Doing so may result in fire, malfunction, or electric shock.
- The projector uses a high-voltage mercury lamp that contains high internal pressure. This lamp may break, emitting a large sound, or fail to illuminate, due to impact or extended use.
- The projector uses of high-wattage lamp that becomes very hot during operation. Please observe the following precautions.
  - Never place objects on top of the projector while it is operation.
  - Make sure there is an unobstructed space of 500 mm or more around the projector's exhaust openings.
  - Do not stack projector units directly on top of one another for the purpose of multiple (stacked) projection. When stacking projector units, be sure to provide the amount of space indicated between them. These space requirements also apply to installation where only one projector unit is operating at one time and the other unit is used as a backup.
  - If the projector is placed in a box or enclosure, ensure the temperature of the air surrounding the projector is between 0°C and 35°C. Also make sure the projector's intake and exhaust openings are not blocked. Take particular care to ensure that hot air from the exhaust openings is not sucked into the intake openings.
- If the projector is to be operated continuously 24 hours a day, use the dual-lamps optical system's alternating lamp operation (lamp changer) function.
  - The projector cannot be operated continuously 24 hours a day in dual-lamp mode.
  - Allow a minimum of two hours per day of non-operation time per day if the using the dual-lamp mode.
- The lamp replacement cycle duration becomes shorter if the projector is operated repeatedly for short periods.
  - The length of time that it takes for the lamp to break or fail to illuminate varies greatly depending on individual lamp characteristics and usage conditions.
  - The brightness of the lamp will gradually decrease with use.
- Because the ET-D75LE5 is a fixed short-throw lens, the lens shift function cannot be used with it.
- When the ET-D75LE6 is mounted to the PT-D7700 or PT-DW7000, the lens cover that is included with the projector cannot be used as is. Please use the lens cover that is included with the ET-D75LE6.

# Panasonic®

For more information about Panasonic projectors  
<http://panasonic.net/avc/projector>



Weights and dimensions shown are approximate. Specifications are subject to change without notice. Product availability differs depending on region and country. This product may be subject to export control regulations. DLP® and the DLP logo are registered trademarks of Texas Instruments. An application has been filed for trademark rights, or trademark rights have been granted, for P.Link in Japan, the United States of America and other countries and areas. All other trademarks are the property of their respective trademark owners. Projection images simulated.

All information included here is valid as of February 2010.

PT-DW7000E6 Printed in Japan.