

S P E C F I L E



The PT-DZ6700L is not equipped with a lens.

Product Number : **PT-DZ6700/DZ6700L**

Product Name : **DLP™ Projectors**

Specifications

Main unit

Power supply		120 V AC, 50/60 Hz 220–240 V AC, 50/60 Hz
Power consumption	120 V AC, 50/60 Hz	820 W (880 VA) (0.2 W with standby mode set to eco* ¹ , 8 W with standby mode set to normal. Both with fan stopped.)
	220–240 V AC, 50/60 Hz	800 W (960 VA) (0.3 W with standby mode set to eco* ¹ , 9 W with standby mode set to normal. Both with fan stopped.)
DLP™ chip	Panel size	17.0 mm (0.67 in) diagonal (16:10 aspect ratio)
	Display method	DLP™ chip × 1, DLP™ system
	Pixels	2,304,000 (1,920 × 1,200) × 1, total of 2,304,000 pixels
Lens	PT-DZ6700	Powered zoom/focus lenses (1.8–2.4:1), F 1.7–2.0, f 26.8–35.7 mm
	PT-DZ6700L	Optional powered zoom/focus lenses and fixed-focus lens
Lamp		300 W UHM lamps (× 2) (dual lamp system)
Screen size		1.27–15.24 m (50–600 inches) (1.27–5.08 m (50–200 inches) with the ET-DLE055), 16:10 aspect ratio
Brightness* ²		6,000 lumens (dual lamp, lamp mode: high)
Center-to-corner uniformity* ²		90%
Contrast* ²		2,000:1 (full on/full off, contrast mode: high, brightness: 3,000 lumens)
Resolution		1,920 × 1,200 pixels
Scanning frequency	RGB/DVI-D	f _H : 15–91 kHz, f _V : 50–85 Hz, dot clock: 162 MHz or lower
	YPbPr (YCbCr)	480i (525i): f _H 15.75 kHz; f _V 60 Hz, 576i (625i): f _H 15.63 kHz; f _V 50 Hz, 480p (525p): f _H 31.50 kHz; f _V 60 Hz, 576p (625p): f _H 31.25 kHz; f _V 50 Hz, 720 (750)/60p: f _H 45.00 kHz; f _V 60 Hz, 720 (750)/50p: f _H 37.50 kHz; f _V 50 Hz, 1035/60i: f _H 33.75 kHz; f _V 60 Hz, 1080 (1125)/60i: f _H 33.75 kHz; f _V 60 Hz, 1080 (1125)/50i: f _H 28.13 kHz; f _V 50 Hz, 1080/25p: f _H 28.13 kHz; f _V 25 Hz, 1080/24p: f _H 27.00 kHz; f _V 24 Hz, 1080/24sF: f _H 27.00 kHz; f _V 48 Hz, 1080/30p: f _H 33.75 kHz; f _V 30 Hz, 1080/60p: f _H 67.50 kHz; f _V 60 Hz, 1080/50p: f _H 56.25 kHz; f _V 50 Hz
	Video/S-Video	f _H : 15.75 kHz, f _V : 60 Hz [NTSC/NTSC4.43/PAL-M/PAL60] f _H : 15.63 kHz, f _V : 50 Hz [PAL/PAL-N/SECAM]
Optical axis shift		Vertical: +50% (powered), horizontal: ±10% (powered)
Keystone correction range		Vertical: ±40° (±30° with the ET-DLE055 and ET-DLE080)
Installation		Ceiling/floor, front/rear
Terminals	DVI-D IN	DVI-D 24-pin × 1, DVI 1.0 compliant, HDCP compatible, for single link only 480p, 576p, 720/60p, 720/50p, 1080/60i, 1080/50i, 1080/24p, 1080/24sF, 1080/25p, 1080/30p, 1080/60p, 1080/50p, VGA (640 × 480)–WUXGA* ³ (1,920 × 1,200), compatible with non-interlaced signals only, dot clock: 25–162 MHz
	RGB 1 IN	BNC × 5
	R, G, B	R: 0.7 Vp-p, 75 ohms, G: 0.7 Vp-p (G: 1.0 Vp-p for sync on G), 75 ohms, B: 0.7 Vp-p, 75 ohms HD/VD, SYNC: High impedance, TTL (positive/negative) NOTE: HD/SYNC, and VD terminals do not accept tri-level sync signals.
	Y, Pb, Pr (Y, Cb, Cr)	Y: 1.0 Vp-p (including sync signal), Pb/Pr: 0.7 Vp-p, 75 ohms

RGB 2 IN	D-sub HD 15-pin × 1
R, G, B	R: 0.7 Vp-p, 75 ohms, G: 0.7 Vp-p (G: 1.0 Vp-p for sync on G), 75 ohms, B: 0.7 Vp-p, 75 ohms HD/VD, SYNC: High impedance, TTL (positive/negative) NOTE: HD/SYNC, and VD terminals do not accept tri-level sync signals.
Y, PB, PR (Y, CB, CR)	Y: 1.0 Vp-p (including sync signal), PB/PR: 0.7 Vp-p, 75 ohms
VIDEO IN	BNC × 1, 1.0 Vp-p, 75 ohms
S-VIDEO IN	Mini DIN 4-pin × 1, Y: 1.0 Vp-p, C: 0.286 Vp-p, 75 ohms
SERIAL IN	D-sub 9-pin × 1 for external control (RS-232C compliant)
SERIAL OUT	D-sub 9-pin × 1 for link control (RS-232C compliant)
REMOTE 1 IN	M3 jack × 1 for wired remote control
REMOTE 1 OUT	M3 jack × 1 for link control
REMOTE 2 IN	D-sub 9-pin × 1 for external control (parallel)
LAN	RJ-45 × 1 for network connection, 100Base-TX/10Base-T, compliant with PLink™
Power cord length	3.0 m (9 ft 10 in)
Cabinet materials	Molded plastic
Dimensions (W × H × D)	PT-DZ6700 498 mm × 175 mm*4 × 440 mm*5 (19-19/32" × 6-7/8" *4 × 17-5/16" *5) (with supplied lens)
	PT-DZ6700L 498 mm × 175 mm*4 × 432 mm (19-19/32" × 6-7/8" *4 × 17") (without lens)
Weight	PT-DZ6700 Approx. 16.0 kg (35.3 lbs)(with supplied lens)
	PT-DZ6700L Approx. 15.2 kg (33.5 lbs)(without lens)
Operating temperature	0°–45°C (32°–113°F)
Operating humidity	20%–80% (no condensation)

Remote control unit

Power supply	3 V DC (R6/AA type battery × 2)
Operation range*6	Approx. 30 m (98 ft 5 in) when operated from directly in front of the signal receptor
Dimensions (W × H × D)	51 × 176 × 23 mm (2" × 6-15/16" × 29/32")
Weight	Approx. 134 g (4.7 oz) (including batteries)

Supplied accessories

- Power cord (× 1)
- Power cord security lock (× 1)
- Wireless/wired remote control unit (× 1)
- Batteries for remote control (R6/AA type × 2)
- Wire rope (× 1)

Optional accessories

Zoom lens (0.78–0.98:1)	ET-DLE080
Zoom lens (1.3–1.9:1)	ET-DLE150
Zoom lens (2.3–3.6:1)	ET-DLE250
Zoom lens (3.6–5.4:1)	ET-DLE350
Zoom lens (5.4–8.6:1)	ET-DLE450
Fixed-focus lens (0.8:1)	ET-DLE055
Replacement lamp unit	ET-LAD60A ET-LAD60AW (Twin Pack)
Ceiling mount bracket	ET-PKD56H (for high ceilings) ET-PKD55S (for low ceilings)

Weights and dimensions shown are approximate. Specifications and appearance are subject to change without notice.

*1 When the standby mode is set to eco, network functions such as power on over the LAN network will not operate, and the serial output terminal cannot be used. Also, only certain commands can be received for external control using the serial terminal.
 *2 Measurement, measuring conditions, and method of notation all comply with ISO 21118 international standards.
 *3 WUXGA resolution is supported only when the signals are compliant with VESA CVT-RB (Coordinated Video Timing-Reduced Blanking).
 *4 With legs at shortest position.
 *5 Including the supplied lens.
 *6 Operation range differs depending on environments.

Dimensions

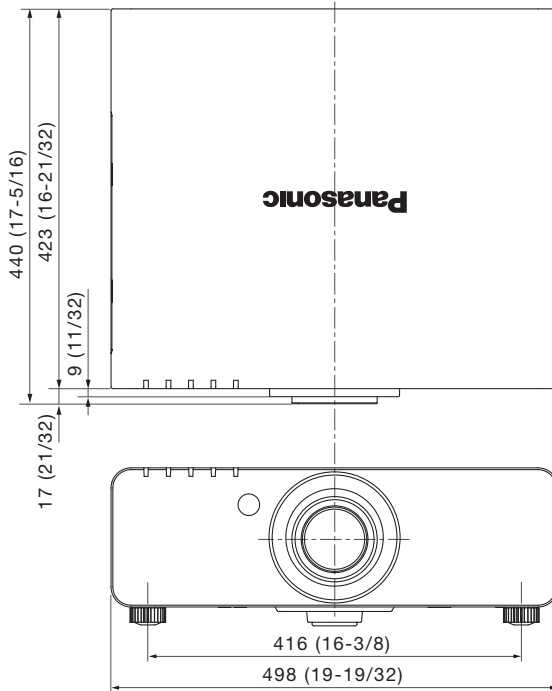

unit : mm (inch)
NOTE: This illustration is not drawn to scale.
The illustration shows the PT-DZ6700.

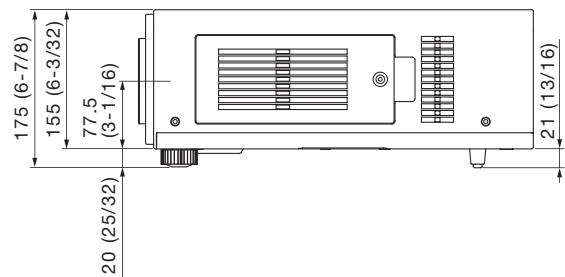

Terminals

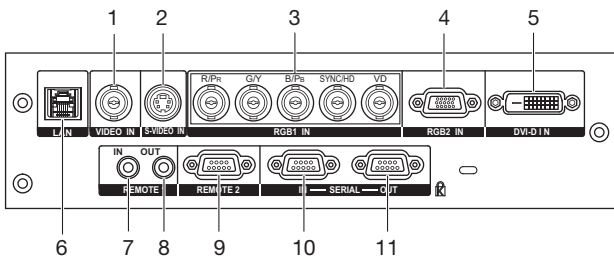

- | | |
|-----------------|-------------------|
| 1 Video input | 7 Remote 1 input |
| 2 S-Video input | 8 Remote 1 output |
| 3 RGB 1 input | 9 Remote 2 input |
| 4 RGB 2 Input | 10 Serial input |
| 5 DVI-D input | 11 Serial output |
| 6 LAN connector | |

Standard setting-up position

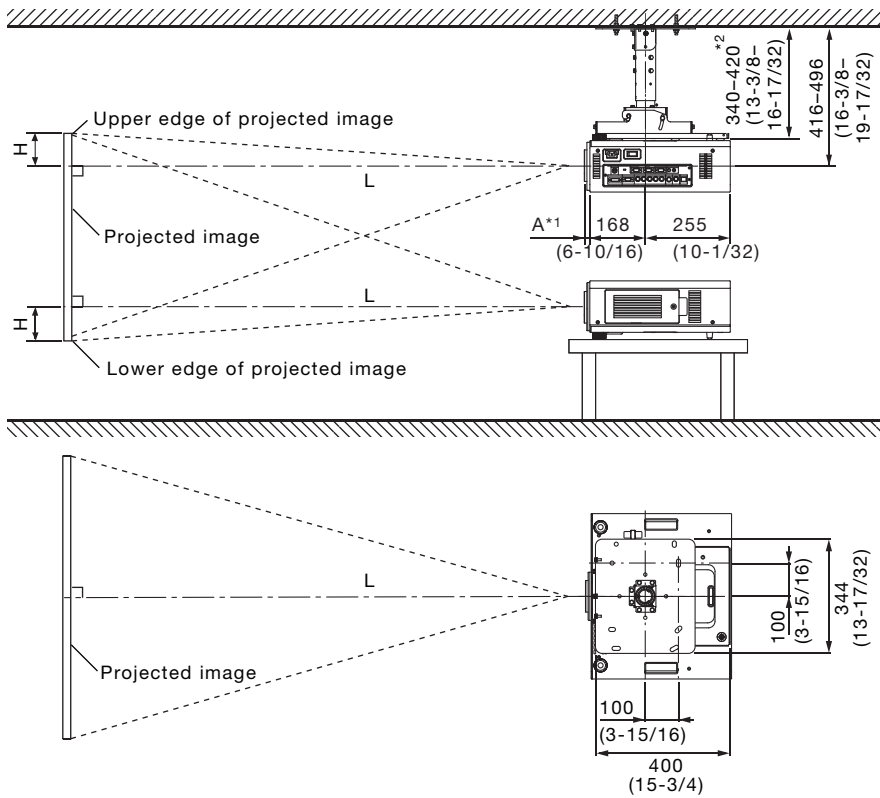

*1 When the lens protrudes to the maximum.
 A: 84 mm (3-5/16") with the ET-DLE080
 17 mm (21/32") with the supplied lens
 44 mm (1-23/32") with the ET-DLE150
 45 mm (1-25/32") with the ET-DLE250
 51 mm (2") with the ET-DLE350
 95 mm (3-3/4") with the ET-DLE450
 27 mm (1-1/16") with the ET-DLE055

*2 Adjustable in 40 mm (1-9/16") steps.

unit : mm (inch)

NOTE:

Illustrations show the projector installed using optional ceiling mount bracket ET-PKD56H and an optional lens. This illustration is not drawn to scale.

Caution:

- All construction work should be done by a qualified technician.
- When mounting to the ceiling, use the special mounting bracket. To prevent the projector from swaying or dropping, attach the wire that is included with the projector between the mounting bracket and the ceiling.

Projection distance for 16:10 aspect ratio screen

Unit: meters

Screen size (diagonal)		Distance to screen (L)												Height from the edge of screen to center of lens (H)		
		Zoom										Fixed-focus				
		ET-DLE080 Zoom lens		ET-DLE150 Zoom lens		<i>Supplied lens</i>		ET-DLE250 Zoom lens		ET-DLE350 Zoom lens		ET-DLE450 Zoom lens		ET-DLE055 Fixed-focus lens	Zoom lenses	Fixed- focus lens
[m]	[in]	min.	max.	min.	max.	<i>min.</i>	<i>max.</i>	min.	max.	min.	max.	min.	max.			
1.27/ 50	0.83	1.04	1.38	2.01	1.90	2.57	2.42	3.87	3.80	5.82	5.66	9.12	0.83	0.00	-0.34	0.34
1.52/ 60	1.00	1.25	1.66	2.43	2.30	3.10	2.92	4.65	4.59	7.00	6.85	11.01	1.00	0.00	-0.40	0.40
1.78/ 70	1.17	1.47	1.95	2.84	2.69	3.63	3.42	5.44	5.38	8.19	8.04	12.89	1.18	0.00	-0.47	0.47
2.03/ 80	1.35	1.68	2.23	3.25	3.09	4.16	3.92	6.23	6.16	9.38	9.24	14.78	1.35	0.00	-0.54	0.54
2.29/ 90	1.52	1.90	2.52	3.66	3.48	4.69	4.42	7.02	6.95	10.57	10.43	16.66	1.53	0.00	-0.61	0.61
2.54/ 100	1.70	2.11	2.81	4.08	3.88	5.22	4.92	7.81	7.74	11.76	11.62	18.55	1.70	0.00	-0.67	0.67
3.05/ 120	2.05	2.55	3.38	4.90	4.67	6.27	5.91	9.39	9.31	14.14	14.00	22.32	2.05	0.00	-0.81	0.81
3.81/ 150	2.57	3.19	4.24	6.14	5.85	7.86	7.41	11.75	11.68	17.71	17.58	27.97	2.58	0.00	-1.01	1.01
5.08/ 200	3.44	4.27	5.67	8.20	7.83	10.50	9.91	15.70	15.61	23.66	23.54	37.39	3.45	0.00	-1.35	1.35
6.35/ 250	4.31	5.35	7.10	10.26	9.80	13.15	12.41	19.64	19.55	29.61	29.50	46.81	-	0.00	-1.68	-
7.62/ 300	5.18	6.43	8.53	12.33	11.78	15.79	14.91	23.59	23.49	35.56	35.46	56.24	-	0.00	-2.02	-
10.16/ 400	6.93	8.59	11.39	16.45	15.73	21.08	19.90	31.48	31.36	47.46	47.38	75.08	-	0.00	-2.69	-
12.70/ 500	8.67	10.75	14.25	20.58	19.68	26.37	24.90	39.37	39.24	59.36	59.30	93.93	-	0.00	-3.37	-
15.24/ 600	10.42	12.91	17.11	24.70	23.63	31.66	29.89	47.26	47.11	71.26	71.22	112.77	-	0.00	-4.04	-

Unit: feet

Screen size (diagonal)		Distance to screen (L)												Height from the edge of screen to center of lens (H)		
		Zoom										Fixed-focus				
		ET-DLE080 Zoom lens		ET-DLE150 Zoom lens		<i>Supplied lens</i>		ET-DLE250 Zoom lens		ET-DLE350 Zoom lens		ET-DLE450 Zoom lens		ET-DLE055 Fixed-focus lens	Zoom lenses	Fixed- focus lens
[m]	[in]	min.	max.	min.	max.	<i>min.</i>	<i>max.</i>	min.	max.	min.	max.	min.	max.			
1.27/ 50	2.7	3.4	4.5	6.6	6.2	8.4	7.9	12.7	12.5	19.1	18.6	29.9	2.7	0.0	- 1.1	1.1
1.52/ 60	3.3	4.1	5.5	8.0	7.5	10.2	9.6	15.3	15.1	23.0	22.5	36.1	3.3	0.0	- 1.3	1.3
1.78/ 70	3.9	4.8	6.4	9.3	8.8	11.9	11.2	17.9	17.6	26.9	26.4	42.3	3.9	0.0	- 1.6	1.6
2.03/ 80	4.4	5.5	7.3	10.7	10.1	13.6	12.8	20.4	20.2	30.8	30.3	48.5	4.4	0.0	- 1.8	1.8
2.29/ 90	5.0	6.2	8.3	12.0	11.4	15.4	14.5	23.0	22.8	34.7	34.2	54.7	5.0	0.0	- 2.0	2.0
2.54/ 100	5.6	6.9	9.2	13.4	12.7	17.1	16.1	25.6	25.4	38.6	38.1	60.8	5.6	0.0	- 2.2	2.2
3.05/ 120	6.7	8.4	11.1	16.1	15.3	20.6	19.4	30.8	30.6	46.4	45.9	73.2	6.7	0.0	- 2.7	2.7
3.81/ 150	8.4	10.5	13.9	20.1	19.2	25.8	24.3	38.6	38.3	58.1	57.7	91.8	8.5	0.0	- 3.3	3.3
5.08/ 200	11.3	14.0	18.6	26.9	25.7	34.5	32.5	51.5	51.2	77.6	77.2	122.7	11.3	0.0	- 4.4	4.4
6.35/ 250	14.1	17.6	23.3	33.7	32.2	43.1	40.7	64.4	64.1	97.1	96.8	153.6	-	0.0	- 5.5	-
7.62/ 300	17.0	21.1	28.0	40.4	38.6	51.8	48.9	77.4	77.1	116.7	116.3	184.5	-	0.0	- 6.6	-
10.16/ 400	22.7	28.2	37.4	54.0	51.6	69.2	65.3	103.3	102.9	155.7	155.4	246.3	-	0.0	- 8.8	-
12.70/ 500	28.5	35.3	46.7	67.5	64.6	86.5	81.7	129.2	128.7	194.7	194.6	308.2	-	0.0	-11.0	-
15.24/ 600	34.2	42.3	56.1	81.0	77.5	103.9	98.1	155.0	154.6	233.8	233.7	370.0	-	0.0	-13.3	-

- The value for L (distance to screen) varies slightly within ±5% depending on the zoom lens characteristics.
- The zoom lens characteristics may cause slight image distortion.
- When vertical keystone correction is used, the image is corrected in the direction that reduces its projected size.
- The brightness varies depending on the zoom setting.

Note: When the ET-DLE055 is mounted, the optical lens shift function cannot be used.

Projection distance for 16:9 aspect ratio screen

Unit: meters

Screen size (diagonal)		Distance to screen (L)												Height from the edge of screen to center of lens (H)		
		Zoom											Fixed-focus			
		ET-DLE080 Zoom lens		ET-DLE150 Zoom lens		<i>Supplied lens</i>		ET-DLE250 Zoom lens		ET-DLE350 Zoom lens		ET-DLE450 Zoom lens		ET-DLE055 Fixed-focus lens	Zoom lenses	Fixed- focus lens
[m]	[in]	min.	max.	min.	max.	<i>min.</i>	<i>max.</i>	min.	max.	min.	max.	min.	max.			
1.27/ 50	0.85	1.07	1.42	2.07	1.96	2.65	2.49	3.98	3.91	5.98	5.82	9.39	0.85	-0.06	-0.31	0.31
1.52/ 60	1.03	1.29	1.71	2.49	2.36	3.19	3.00	4.79	4.72	7.20	7.05	11.32	1.03	-0.08	-0.37	0.37
1.78/ 70	1.21	1.51	2.00	2.92	2.77	3.73	3.51	5.60	5.53	8.43	8.28	13.26	1.21	-0.09	-0.44	0.44
2.03/ 80	1.39	1.73	2.30	3.34	3.17	4.28	4.03	6.41	6.34	9.65	9.50	15.20	1.39	-0.10	-0.50	0.50
2.29/ 90	1.57	1.95	2.59	3.77	3.58	4.82	4.54	7.22	7.15	10.87	10.73	17.13	1.57	-0.11	-0.56	0.56
2.54/ 100	1.75	2.17	2.89	4.19	3.99	5.36	5.05	8.03	7.96	12.09	11.95	19.07	1.75	-0.13	-0.62	0.62
3.05/ 120	2.10	2.62	3.47	5.04	4.80	6.45	6.08	9.65	9.58	14.54	14.40	22.94	2.11	-0.15	-0.75	0.75
3.81/ 150	2.64	3.28	4.36	6.31	6.02	8.08	7.62	12.08	12.00	18.21	18.08	28.75	2.65	-0.19	-0.93	0.93
5.08/ 200	3.54	4.39	5.83	8.43	8.05	10.80	10.19	16.14	16.05	24.32	24.20	38.44	3.55	-0.25	-1.25	1.25
6.35/ 250	4.43	5.50	7.29	10.55	10.08	13.52	12.76	20.19	20.10	30.44	30.33	48.12	-	-0.31	-1.56	-
7.62/ 300	5.33	6.61	8.76	12.67	12.11	16.23	15.32	24.25	24.14	36.55	36.45	57.81	-	-0.37	-1.87	-
10.16/ 400	7.12	8.83	11.70	16.91	16.17	21.67	20.46	32.35	32.24	48.78	48.71	77.18	-	-0.50	-2.49	-
12.70/ 500	8.91	11.05	14.64	21.15	20.23	27.11	25.59	40.46	40.33	61.01	60.96	96.55	-	-0.62	-3.11	-
15.24/ 600	10.71	13.27	17.58	25.39	24.29	32.54	30.72	48.57	48.42	73.24	73.21	115.92	-	-0.75	-3.74	-

Unit: feet

Screen size (diagonal)		Distance to screen (L)												Height from the edge of screen to center of lens (H)		
		Zoom											Fixed-focus			
		ET-DLE080 Zoom lens		ET-DLE150 Zoom lens		<i>Supplied lens</i>		ET-DLE250 Zoom lens		ET-DLE350 Zoom lens		ET-DLE450 Zoom lens		ET-DLE055 Fixed-focus lens	Zoom lenses	Fixed- focus lens
[m]	[in]	min.	max.	min.	max.	<i>min.</i>	<i>max.</i>	min.	max.	min.	max.	min.	max.			
1.27/ 50	2.8	3.5	4.6	6.8	6.4	8.7	8.2	13.0	12.8	19.6	19.1	30.8	2.8	-0.2	-1.0	1.0
1.52/ 60	3.4	4.2	5.6	8.2	7.7	10.5	9.8	15.7	15.5	23.6	23.1	37.1	3.4	-0.3	-1.2	1.2
1.78/ 70	4.0	5.0	6.6	9.6	9.1	12.2	11.5	18.4	18.1	27.6	27.1	43.5	4.0	-0.3	-1.4	1.4
2.03/ 80	4.6	5.7	7.5	11.0	10.4	14.0	13.2	21.0	20.8	31.7	31.2	49.9	4.6	-0.3	-1.6	1.6
2.29/ 90	5.1	6.4	8.5	12.4	11.7	15.8	14.9	23.7	23.5	35.7	35.2	56.2	5.2	-0.4	-1.8	1.8
2.54/ 100	5.7	7.1	9.5	13.8	13.1	17.6	16.6	26.3	26.1	39.7	39.2	62.6	5.7	-0.4	-2.0	2.0
3.05/ 120	6.9	8.6	11.4	16.5	15.7	21.2	20.0	31.7	31.4	47.7	47.2	75.3	6.9	-0.5	-2.5	2.5
3.81/ 150	8.7	10.8	14.3	20.7	19.7	26.5	25.0	39.6	39.4	59.7	59.3	94.3	8.7	-0.6	-3.1	3.1
5.08/ 200	11.6	14.4	19.1	27.7	26.4	35.4	33.4	52.9	52.7	79.8	79.4	126.1	11.7	-0.8	-4.1	4.1
6.35/ 250	14.5	18.1	23.9	34.6	33.1	44.3	41.8	66.2	65.9	99.9	99.5	157.9	-	-1.0	-5.1	-
7.62/ 300	17.5	21.7	28.8	41.6	39.7	53.3	50.3	79.5	79.2	119.9	119.6	189.7	-	-1.2	-6.1	-
10.16/ 400	23.4	29.0	38.4	55.5	53.0	71.1	67.1	106.1	105.8	160.0	159.8	253.2	-	-1.6	-8.2	-
12.70/ 500	29.2	36.3	48.0	69.4	66.4	88.9	84.0	132.7	132.3	200.2	200.0	316.8	-	-2.0	-10.2	-
15.24/ 600	35.1	43.5	57.7	83.3	79.7	106.8	100.8	159.4	158.9	240.3	240.2	380.3	-	-2.5	-12.3	-

- The value for L (distance to screen) varies slightly within ±5% depending on the zoom lens characteristics.
- The zoom lens characteristics may cause slight image distortion.
- When vertical keystone correction is used, the image is corrected in the direction that reduces its projected size.
- The brightness varies depending on the zoom setting.

Note: When the ET-DLE055 is mounted, the optical lens shift function cannot be used.

Projection distance for 4:3 aspect ratio screen

Unit: meters

Screen size (diagonal)		Distance to screen (L)												Height from the edge of screen to center of lens (H)		
		Zoom										Fixed-focus				
		ET-DLE080 Zoom lens		ET-DLE150 Zoom lens		<i>Supplied lens</i>		ET-DLE250 Zoom lens		ET-DLE350 Zoom lens		ET-DLE450 Zoom lens				ET-DLE055 Fixed-focus lens
[m]	[in]	min.	max.	min.	max.	<i>min.</i>	<i>max.</i>	min.	max.	min.	max.	min.	max.			
1.27/	50	0.94	1.18	1.57	2.29	2.16	2.92	2.75	4.39	4.32	6.60	6.45	10.37	0.94	0.00–0.38	0.38
1.52/	60	1.14	1.42	1.89	2.75	2.61	3.52	3.31	5.28	5.21	7.95	7.80	12.50	1.14	0.00–0.46	0.46
1.78/	70	1.34	1.67	2.21	3.22	3.06	4.12	3.88	6.17	6.11	9.29	9.15	14.64	1.34	0.00–0.53	0.53
2.03/	80	1.53	1.91	2.54	3.69	3.50	4.72	4.44	7.07	7.00	10.64	10.49	16.77	1.54	0.00–0.61	0.61
2.29/	90	1.73	2.16	2.86	4.15	3.95	5.32	5.01	7.96	7.89	11.99	11.84	18.90	1.74	0.00–0.69	0.69
2.54/	100	1.93	2.40	3.18	4.62	4.40	5.91	5.58	8.85	8.78	13.34	13.19	21.04	1.93	0.00–0.76	0.76
3.05/	120	2.32	2.89	3.83	5.56	5.29	7.11	6.71	10.64	10.56	16.03	15.89	25.30	2.33	0.00–0.91	0.91
3.81/	150	2.91	3.62	4.80	6.96	6.63	8.91	8.40	13.32	13.24	20.07	19.94	31.70	2.93	0.00–1.14	1.14
5.08/	200	3.90	4.84	6.42	9.29	8.87	11.90	11.23	17.78	17.69	26.81	26.69	42.37	3.92	0.00–1.52	1.52
6.35/	250	4.89	6.07	8.04	11.63	11.11	14.90	14.06	22.25	22.15	33.54	33.44	53.04	–	0.00–1.91	–
7.62/	300	5.88	7.29	9.66	13.96	13.34	17.89	16.88	26.71	26.61	40.28	40.18	63.70	–	0.00–2.29	–
10.16/	400	7.85	9.73	12.90	18.63	17.82	23.88	22.54	35.65	35.52	53.74	53.68	85.04	–	0.00–3.05	–
12.70/	500	9.82	12.17	16.13	23.30	22.29	29.86	28.19	44.58	44.44	67.21	67.17	106.37	–	0.00–3.81	–
15.24/	600	11.80	14.62	19.37	27.97	26.76	35.85	33.85	53.51	53.35	80.68	80.67	127.71	–	0.00–4.57	–

Unit: feet

Screen size (diagonal)		Distance to screen (L)												Height from the edge of screen to center of lens (H)		
		Zoom										Fixed-focus				
		ET-DLE080 Zoom lens		ET-DLE150 Zoom lens		<i>Supplied lens</i>		ET-DLE250 Zoom lens		ET-DLE350 Zoom lens		ET-DLE450 Zoom lens				ET-DLE055 Fixed-focus lens
[m]	[in]	min.	max.	min.	max.	<i>min.</i>	<i>max.</i>	min.	max.	min.	max.	min.	max.			
1.27/	50	3.1	3.9	5.1	7.5	7.1	9.6	9.0	14.4	14.2	21.7	21.1	34.0	3.1	0.0–1.3	1.3
1.52/	60	3.7	4.7	6.2	9.0	8.6	11.5	10.9	17.3	17.1	26.1	25.6	41.0	3.7	0.0–1.5	1.5
1.78/	70	4.4	5.5	7.3	10.6	10.0	13.5	12.7	20.3	20.0	30.5	30.0	48.0	4.4	0.0–1.8	1.8
2.03/	80	5.0	6.3	8.3	12.1	11.5	15.5	14.6	23.2	23.0	34.9	34.4	55.0	5.0	0.0–2.0	2.0
2.29/	90	5.7	7.1	9.4	13.6	13.0	17.4	16.4	26.1	25.9	39.3	38.9	62.0	5.7	0.0–2.3	2.3
2.54/	100	6.3	7.9	10.4	15.2	14.4	19.4	18.3	29.0	28.8	43.8	43.3	69.0	6.3	0.0–2.5	2.5
3.05/	120	7.6	9.5	12.6	18.2	17.4	23.3	22.0	34.9	34.7	52.6	52.1	83.0	7.6	0.0–3.0	3.0
3.81/	150	9.6	11.9	15.8	22.8	21.8	29.2	27.6	43.7	43.4	65.8	65.4	104.0	9.6	0.0–3.8	3.8
5.08/	200	12.8	15.9	21.1	30.5	29.1	39.0	36.8	58.3	58.0	87.9	87.6	139.0	12.8	0.0–5.0	5.0
6.35/	250	16.0	19.9	26.4	38.1	36.4	48.9	46.1	73.0	72.7	110.0	109.7	174.0	–	0.0–6.3	–
7.62/	300	19.3	23.9	31.7	45.8	43.8	58.7	55.4	87.6	87.3	132.1	131.8	209.0	–	0.0–7.5	–
10.16/	400	25.8	31.9	42.3	61.1	58.4	78.3	73.9	116.9	116.5	176.3	176.1	279.0	–	0.0–10.0	–
12.70/	500	32.2	39.9	52.9	76.5	73.1	98.0	92.5	146.2	145.8	220.5	220.4	349.0	–	0.0–12.5	–
15.24/	600	38.7	48.0	63.6	91.8	87.8	117.6	111.0	175.5	175.0	264.7	264.7	419.0	–	0.0–15.0	–

- The value for L (distance to screen) varies slightly within ±5% depending on the zoom lens characteristics.
- The zoom lens characteristics may cause slight image distortion.
- When vertical keystone correction is used, the image is corrected in the direction that reduces its projected size.
- The brightness varies depending on the zoom setting.

Note: When the ET-DLE055 is mounted, the optical lens shift function cannot be used.

Calculation of the projection distance

For a screen size different from the above, use the equation below to calculate the projection distance.

Aspect ratio 16:10

ET-DLE080	minimum	$L (m) = (\text{diagonal screen size in inches}) \times 0.0174 - 0.0471$
	maximum	$L (m) = (\text{diagonal screen size in inches}) \times 0.0216 - 0.0442$
ET-DLE150	minimum	$L (m) = (\text{diagonal screen size in inches}) \times 0.0286 - 0.0540$
	maximum	$L (m) = (\text{diagonal screen size in inches}) \times 0.0413 - 0.0498$
<i>Supplied lens</i>	<i>minimum</i>	$L (m) = (\text{diagonal screen size in inches}) \times 0.0395 - 0.0745$
	<i>maximum</i>	$L (m) = (\text{diagonal screen size in inches}) \times 0.0529 - 0.0734$
ET-DLE250	minimum	$L (m) = (\text{diagonal screen size in inches}) \times 0.0500 - 0.0800$
	maximum	$L (m) = (\text{diagonal screen size in inches}) \times 0.0789 - 0.0792$
ET-DLE350	minimum	$L (m) = (\text{diagonal screen size in inches}) \times 0.0787 - 0.1351$
	maximum	$L (m) = (\text{diagonal screen size in inches}) \times 0.1190 - 0.1346$
ET-DLE450	minimum	$L (m) = (\text{diagonal screen size in inches}) \times 0.1192 - 0.3017$
	maximum	$L (m) = (\text{diagonal screen size in inches}) \times 0.1885 - 0.2991$
ET-DLE055	(fixed focus)	$L (m) = (\text{diagonal screen size in inches}) \times 0.0175 - 0.0476$

Aspect ratio 16:9

ET-DLE080	minimum	$L (m) = (\text{diagonal screen size in inches}) \times 0.0179 - 0.0471$
	maximum	$L (m) = (\text{diagonal screen size in inches}) \times 0.0222 - 0.0442$
ET-DLE150	minimum	$L (m) = (\text{diagonal screen size in inches}) \times 0.0294 - 0.0540$
	maximum	$L (m) = (\text{diagonal screen size in inches}) \times 0.0424 - 0.0498$
<i>Supplied lens</i>	<i>minimum</i>	$L (m) = (\text{diagonal screen size in inches}) \times 0.0406 - 0.0745$
	<i>maximum</i>	$L (m) = (\text{diagonal screen size in inches}) \times 0.0544 - 0.0734$
ET-DLE250	minimum	$L (m) = (\text{diagonal screen size in inches}) \times 0.0513 - 0.0800$
	maximum	$L (m) = (\text{diagonal screen size in inches}) \times 0.0811 - 0.0792$
ET-DLE350	minimum	$L (m) = (\text{diagonal screen size in inches}) \times 0.0809 - 0.1351$
	maximum	$L (m) = (\text{diagonal screen size in inches}) \times 0.1223 - 0.1346$
ET-DLE450	minimum	$L (m) = (\text{diagonal screen size in inches}) \times 0.1225 - 0.3017$
	maximum	$L (m) = (\text{diagonal screen size in inches}) \times 0.1937 - 0.2991$
ET-DLE055	(fixed focus)	$L (m) = (\text{diagonal screen size in inches}) \times 0.0180 - 0.0476$

Aspect ratio 4:3

ET-DLE080	minimum	$L (m) = (\text{diagonal screen size in inches}) \times 0.0197 - 0.0471$
	maximum	$L (m) = (\text{diagonal screen size in inches}) \times 0.0244 - 0.0442$
ET-DLE150	minimum	$L (m) = (\text{diagonal screen size in inches}) \times 0.0324 - 0.0540$
	maximum	$L (m) = (\text{diagonal screen size in inches}) \times 0.0467 - 0.0498$
<i>Supplied lens</i>	<i>minimum</i>	$L (m) = (\text{diagonal screen size in inches}) \times 0.0447 - 0.0745$
	<i>maximum</i>	$L (m) = (\text{diagonal screen size in inches}) \times 0.0599 - 0.0734$
ET-DLE250	minimum	$L (m) = (\text{diagonal screen size in inches}) \times 0.0565 - 0.0800$
	maximum	$L (m) = (\text{diagonal screen size in inches}) \times 0.0893 - 0.0792$
ET-DLE350	minimum	$L (m) = (\text{diagonal screen size in inches}) \times 0.0891 - 0.1351$
	maximum	$L (m) = (\text{diagonal screen size in inches}) \times 0.1347 - 0.1346$
ET-DLE450	minimum	$L (m) = (\text{diagonal screen size in inches}) \times 0.1350 - 0.3017$
	maximum	$L (m) = (\text{diagonal screen size in inches}) \times 0.2133 - 0.2991$
ET-DLE055	(fixed focus)	$L (m) = (\text{diagonal screen size in inches}) \times 0.0198 - 0.0476$

• Distances calculated with the above equations will include a slight error.

Shift range

Optical axis shift function allows to shift the position of a projected image as shown below.

• Floor mount

(When the lens except the ET-DLE080 is mounted.)

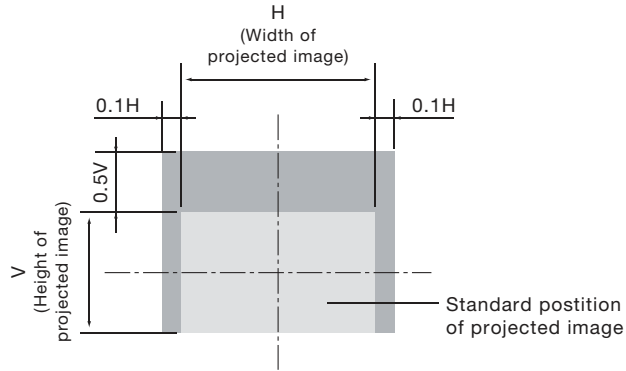

• Ceiling mount

(When the lens except the ET-DLE080 is mounted.)

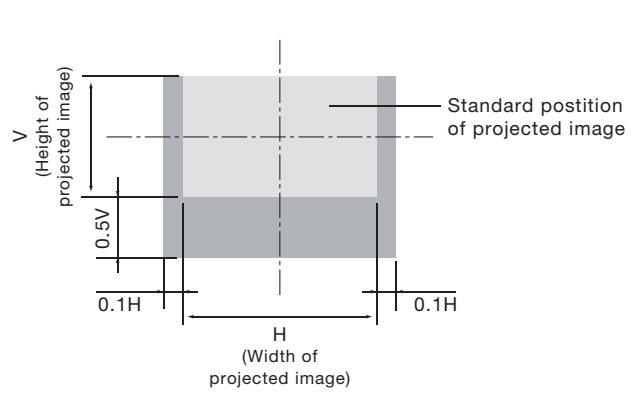

• Floor mount

(When the ET-DLE080 is mounted.)

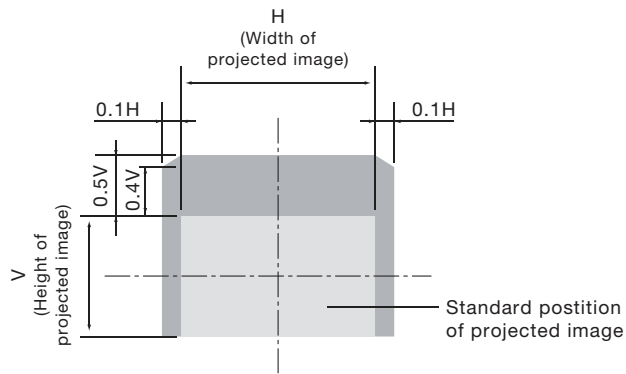

• Ceiling mount

(When the ET-DLE080 is mounted.)

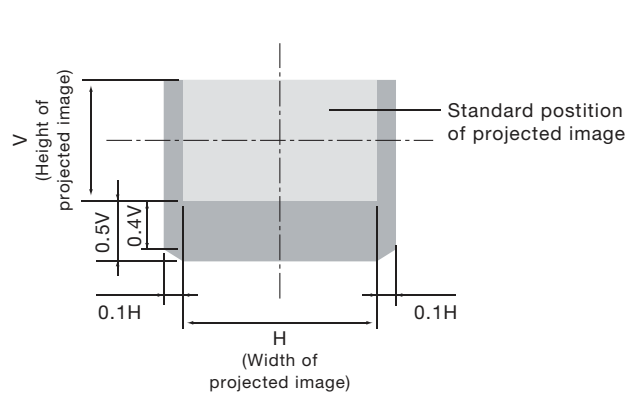

• The ET-DLE055 has a fixed short-focus lens. Therefore, the lens shift function provided in the main unit cannot be used.

Installable angle

Install the projector at an angle within the range shown below.

• Vertical direction

The projector may be installed at a vertical angle of 360°.

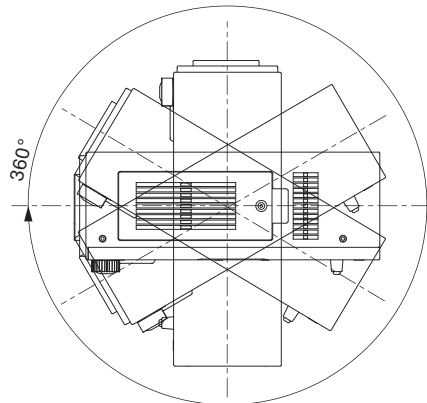

• Horizontal direction

The projector may be installed at a horizontal angle of ±10°.

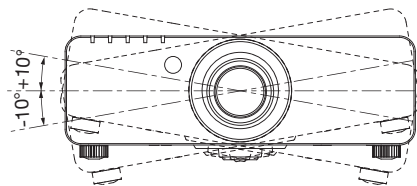

List of compatible signals

The signals that can be input to this projector are shown in the table below. Horizontal scanning frequencies of 15 kHz to 91 kHz, vertical scanning frequencies of 50 Hz to 85 Hz, and a dot clock of 162 MHz maximum can be input.

NOTE: The native resolution of this projector is 1,920 × 1,200 pixels. If the display resolution of the input signal is different from the native resolution, image compression or expansion will be used to convert the input signal to a level within the native resolution.

Display mode	Display resolution (dots) ¹	Scanning frequency H (kHz)	Scanning frequency V (kHz)	Dot clock frequency (MHz)	Picture quality ²	Format
NTSC/NTSC4.43/PAL-M/PAL60	720 x 480i	15.7	59.9	–	A	VIDEO/S-VIDEO
PAL/PAL-N/SECAM	720 x 576i	15.6	50.0	–	A	
480i (525i)	720 x 480i	15.7	59.9	13.5	A	YPbPr /RGB
576i (625i)	720 x 576i	15.6	50.0	13.5	A	
480p (525p)	720 x 483	31.5	59.9	27.0	A	YPbPr /RGB/DVI-D
576p (625p)	720 x 576	31.3	50.0	27.0	A	
720/60p	1,280 x 720	45.0	60.0	74.3	A	
720/50p		37.5	50.0	74.3	A	
1080/60i	1,920 x 1,080i	33.8	60.0	74.3	AA	
1080/50i		28.1	50.0	74.3	AA	
1080/24p	1,920 x 1,080	27.0	24.0	74.3	AA	
1080/24sF	1,920 x 1,080i	27.0	24.0	74.3	AA	
1080/25p	1,920 x 1,080	28.1	50.0	74.3	AA	
1080/30p		33.8	60.0	74.3	AA	
1080/60p		67.5	60.0	148.5	AA	
1080/50p		56.3	50.0	148.5	AA	
VGA400	640 x 400	31.5	70.1	25.2	A	RGB/DVI-D
		37.9	85.1	31.5	A	
VGA480	640 x 480	31.5	59.9	25.2	A	
		35.0	66.7	30.2	A	
		37.9	72.8	31.5	A	
		37.5	75.0	31.5	A	
		43.3	85.0	36.0	A	
SVGA	800 x 600	35.2	56.3	36.0	A	
		37.9	60.3	40.0	A	
		48.1	72.2	50.0	A	
		46.9	75.0	49.5	A	
		53.7	85.1	56.3	A	
MAC16	832 x 624	49.7	74.6	57.3	A	
XGA	1,024 x 768	39.6	50.0	51.9	A	
		48.4	60.0	65.0	A	
		56.5	70.1	75.0	A	
		60.0	75.0	78.8	A	
		65.5	81.6	86.0	A	
		68.7	85.0	94.5	A	
		80.0	100.0	105.0	A	
		96.7	120.0	130.0	A	
MXGA	1,152 x 864	64.0	71.2	94.2	A	
		67.5	74.9	108.0	A	
		76.7	85.0	121.5	A	
MAC21	1,152 x 870	68.7	75.1	100.0	A	
1280 x 768	1,280 x 768	39.6	49.9	65.3	A	
		47.8	59.9	79.5	A	
1280 x 800	1,280 x 800	41.3	50.0	68.0	A	
		49.7	59.8	83.5	A	
MSXGA	1,280 x 960	60.0	60.0	108.0	A	
SXGA	1,280 x 1,024	64.0	60.0	108.0	A	
		80.0	75.0	135.0	A	
		91.1	85.0	157.5	A	
SXGA+	1,400 x 1,050	64.0	60.0	108.0	A	
		82.2	75.0	155.9	A	
WXGA+	1,440 x 900	55.9	59.9	106.5	A	
UXGA	1,600 x 1,200	75.0	60.0	162.0	A	
WSXGA+	1,680 x 1,050	65.3	60.0	146.3	A	
1920 x 1080 ³	1,920 x 1,080	66.6	59.9	138.5	AA	
WUXGA ³	1,920 x 1,200	74.0	60.0	154.0	AA	

1. The “i” appearing after the resolution indicates an interlaced signal.

2. The following symbols are used to indicate picture quality.

AA Maximum picture quality can be obtained.

A Signals are converted by the image processing circuit before picture is projected.

3. Compliant with VESA CVT-RB (Coordinated Video Timing-Reduced Blanking).

Serial connector

The serial connector complies with RS-232C. To control the projector from a personal computer, commands must be input through communication software, based on the format and satisfying the communication conditions shown below.

Pin assignments and signal names

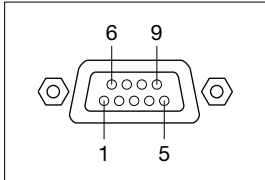

D-sub 9-pin (female) Serial input

No.	Signal name	Description	No.	Signal name	Description
1	-	NC	6	-	NC
2	TXD	Send data	7	CTS	Connected internally
3	RXD	Receive data	8	RTS	Connected internally
4	-	Connected internally	9	-	NC
5	GND	Ground			

Pin assignments and signal names

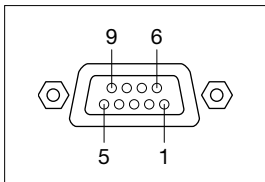

D-sub 9-pin (male) Serial output

No.	Signal name	Description	No.	Signal name	Description
1	-	NC	6	-	NC
2	RXD	Receive data	7	RTS	Connected internally
3	TXD	Send data	8	CTS	Connected internally
4	-	Connected internally	9	-	NC
5	GND	Ground			

Communication conditions (factory setting)

Signal level	RS-232C-compliant
Synchronization method	Start-stop synchronization
Baud rate	9,600 bps
Parity	None
Character length	8 bits
Stop bit	1 bit
X parameter	None
S parameter	None

Basic format

Transmission from the computer begins with STX, then the ID, command, parameter, and ETX are sent in this order. Add parameters according to the details of control.

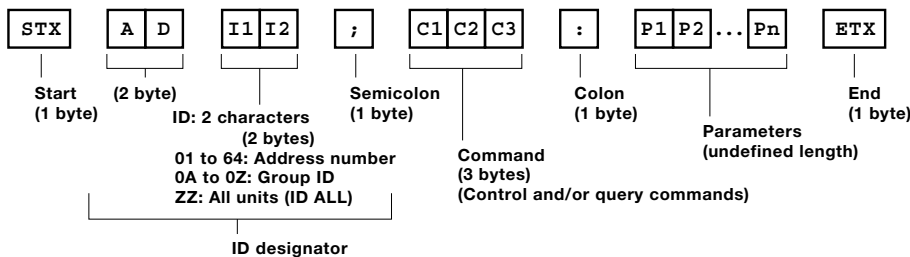

CAUTION

- It may not be possible to send or receive commands for about 10 to 60 seconds when the lamp is first turned on. If this occurs, wait for 60 seconds, then try sending or receiving again.
- When sending multiple commands, be sure to wait for at least 0.5 second after receiving a response from the projector before sending the next command.
- Additional time is sometimes required for response due to processing inside the projector. Set the time-out period for command response to 10 seconds or more.
- When using two or more units:
 - 1) Set different IDs for each unit.
 - 2) Designate only one unit as RESPONSE (ID ALL) ON and the rest as RESPONSE (ID ALL) OFF.
 - 3) Each group should have only one RESPONSE (ID GROUP) ON and the rest should be RESPONSE (ID GROUP) OFF.

Cable specifications

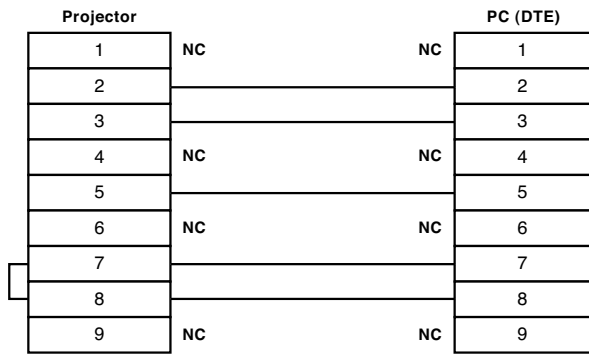

Control commands

Command : Parameter	Function		Callback
PON	POWER (STANDBY)	Standby power on	PON
POF		Standby power off	POF
IIS : DVI	INPUT SELECT	DVI	IIS : DVI
IIS : RG1		RGB 1	IIS : RG1
IIS : RG2		RGB 2	IIS : RG2
IIS : VID		Video	IIS : VID
IIS : SVD		S-Video	IIS : SVD
LPM : 0	LAMP SELECT	Dual (two lamps)	LPM : 0
LPM : 1		Single lamp	LPM : 1
LPM : 2		Lamp 1	LPM : 2
LPM : 3		Lamp 2	LPM : 3
OSH : 0	SHUTTER	Shutter on	OSH : 0
OSH : 1		Shutter off	OSH : 1
OFZ : 0	FREEZE	Off	OFZ : 0
OFZ : 1		On	OFZ : 1
OAS	AUTO SETUP		OAS
VPM : NAT	PICTURE MODE	Natural	VPM : NAT
VPM : STD		Standard	VPM : STD
VPM : DYN		Dynamic	VPM : DYN
VPM : CIN		Cinema	VPM : CIN
VPM : GRA		Graphic	VPM : GRA
VXX : DLVI0 = +00000	SYSTEM DAYLIGHT VIEW 2	Off	VXX : DLVI0 = +00000
VXX : DLVI0 = +00001		1	VXX : DLVI0 = +00001
VXX : DLVI0 = +00002		2	VXX : DLVI0 = +00002
VXX : DLVI0 = +00003		3	VXX : DLVI0 = +00003
OTE : 1	COLOR TEMPERATURE	Middle	OTE : 1
OTE : 2		High	OTE : 2
OTE : 4		User	OTE : 4
OTE : 10		Default	OTE : 10
TSD : y1y2y3y4m1m2d1d2w	DATE	Date setting	TSD : y1y2y3y4m1m2d1d2w
TST : h1h2m1m2s1s2	TIME	Time setting	TST : h1h2m1m2s1s2
OOS : 0	ON SCREEN	On-screen display off	OOS : 0
OOS : 1		On-screen display on	OOS : 1

* Do not send PON, POF or OSH commands continuously in a short period of time. Doing so may burst the lamp or shorten the lamp replacement cycle.
 * When a command that cannot be executed during standby mode is sent, the projector will send an ER401 command in reply.

Status request commands

Command:Parameter	Function	Callback	Description
QPW	Main power status	000	Standby (Off)
		001	On
QSH	Shutter function status	0	Off
		1	On
QFZ	Freeze function status	0	Off
		1	On
QIN	Input signal status	DVI	DVI
		RG1	RGB 1
		RG2	RGB 2
		VID	Video
		SVD	S-Video
QOS	On-screen display status	0	Off
		1	On
QST	Projector run time	p1p2p3p4p5	00000h–99999h
Q\$L:1	Lamp 1 run time	p1p2p3p4	0000h–9999h
Q\$L:2	Lamp 2 run time	p1p2p3p4	0000h–9999h
QSL	Lamp operation mode status	0	Dual
		1	Single
		2	Lamp 1
		3	Lamp 2
QLP	Lamp power mode status	0	High
		1	Low
		NAT	Natural
		STD	Standard
		DYN	dynamic
QPM	Picture mode status	CIN	Cinema
		GRA	Graphic
		DLVI0=+00000	Off
QVX:DLVI0	System daylight view status	DLVI0=+00001	1
		DLVI0=+00002	2
		DLVI0=+00003	3
		QTM:0	Temperature status
QTM:1	p1 = Exhaust air		
QTM:2	p2 = DLP™ chip		
QGD	Date setting status	y1y2y3y4m1m2d1d2w	yyyymmdd (day of week) ^(**)
QGT	Time setting status	h1h2m1m2s1s2	hhmmss

*1 p1p2p3p4: Celsius (°C), p5p6p7p8: Fahrenheit (°F)
 *2 Day of week: Monday = 1, Tuesday = 2, ... Sunday = 7

NOTE: If a wrong command is received, the projector will send an ER401 or ER402 command to the computer.

Command example

To set the on-screen display off, send the command as shown below.



NOTE: When sending commands without parameters, a colon (:) is not necessary.

Notes on projector placement and operation

The projector uses a high-wattage lamp that becomes very hot during operation. Please observe the following precautions.

1. Never place objects on top of the projector while it is operating.
2. Make sure there is an unobstructed space of 500 mm (19-11/16") or more around the projector's exhaust openings.
3. Do not stack projector units directly on top of one another. If two units must be stacked for back-up use in ordinary projection, use a method as shown below and provide ample space between the units to ensure that exhaust heat does not accumulate near the intake opening or around the units. Dual stacked projection is not recommended.
4. Make sure that nothing blocks the projector's air intake and exhaust openings. Also, install the projector so that cool or hot air from other air conditioning equipment does not flow directly toward the projector's air intake or exhaust openings.
5. Do not install the projector in an enclosed space. If it is necessary to install it in an enclosed space, add a separate ventilation system. If ventilation is insufficient, hot air will accumulate at the intake opening. This may cause the projector's protective circuit to interrupt projector operation, or may shorten the replacement cycle for the Auto Cleaning Filter (ACF) Unit.
6. If the projector is installed in an enclosed space, ensure that the temperature of the air surrounding the projector is between 0°C (32°F) and 40°C (104°F). Also make sure that the projector's intake and exhaust openings are not blocked. Even though the air surrounding the projector is 40°C (104°F) or less, if hot exhaust air accumulates inside the space, it may cause the projector's protective circuit to interrupt projector operation, or may shorten the replacement cycle for the ACF Unit. Pay particular attention to the surrounding temperature conditions when planning the installation.

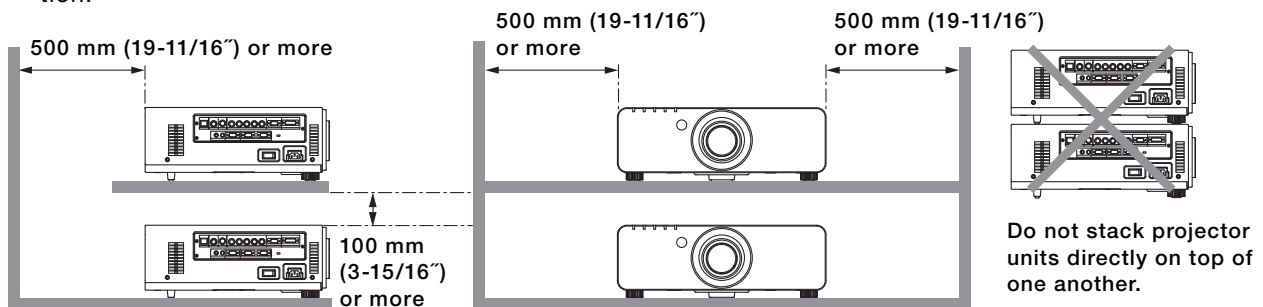

Direction of air intake and exhaust

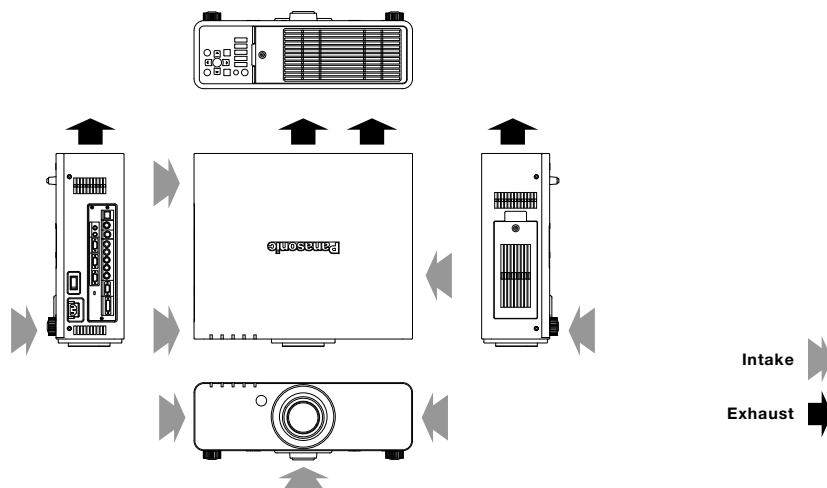

Operating the projector continuously

1. If the projector is to be operated continuously for 24 hours, use the dual-lamp optical system's alternating lamp operation (lamp relay) function. Continuously operating the projector for 24 hours in the dual-lamp mode is not recommended. Allow a minimum of two hours per day of non-operation time for each lamp if the projector is to be operated continuously for more than 22 hours.
2. The lamp replacement cycle duration becomes shorter if the projector is operated repeatedly for short periods.

Replacing the filter unit

The projector is equipped with the Auto Cleaning Filter (ACF) function, which automatically winds the air filter to set a new filter element in place according to operating conditions. The filter unit replacement cycle is approximately 10,000 hours*. Please purchase the ET-ACF100 filter unit for replacement use.

* The replacement cycle given here is a guideline. It may differ depending on the usage environment.

Weights and dimensions shown are approximate. Specifications and appearance are subject to change without notice.
Product availability differs depending on region and country. This product may be subject to export control regulations.

DLP and the DLP logo are trademarks of Texas Instruments.

PJLink is a registered trademark, or a trademark application has been filed, in Japan, the United States, and other countries and regions.
All other trademarks are the property of their respective trademark owners.