

Panasonic®

Installation Instructions

Smoke-cut filter for DLP® Based Projectors

Model No. **ET-SFD100**

Thank you for choosing the smoke-cut filter for Panasonic DLP® Based Projectors.

■ Only a qualified installer should install this product.

Read these instructions completely before installing this product.

Precautions with regard to safety

CAUTION

- This filter can be used for approximately 24 hours in smoky environments. If it is used for more than approximately 24 hours, operating problems may occur.
- Do not wash the smoke-cut filter with water.
- Do not reuse.
- Do not use the filter at high altitudes (1 400 m or more above sea level) or in places where the ambient temperature is 35 °C or higher.

Installing the smoke-cut filter

Installation procedure

1. Turn off the main power and remove the power plug from the receptacle.

- Be sure to observe the procedure "Powering off the projector" of the projector's Operating Instructions and then remove the power plug.

2. Use a Phillips screwdriver to loosen the filter cleaning unit fixing screw at the front of the projector.

- Insert your hand into the base of the air filter and pull the air filter forwards while removing the filter cleaning unit from the projector.

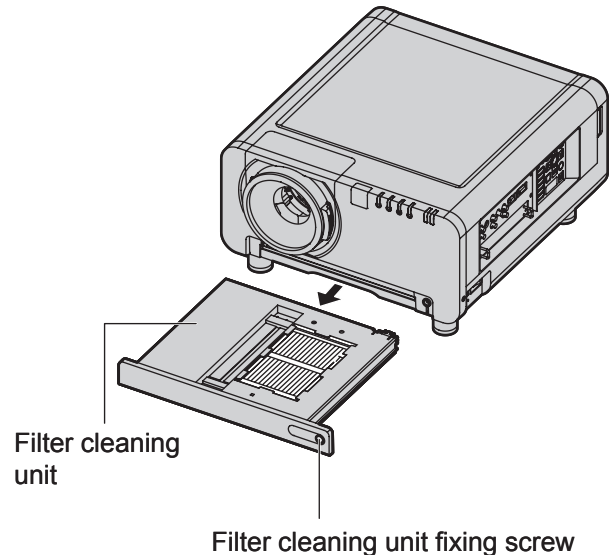

3. Insert the smoke-cut filter securely into the projector as far as it will go, and then use a Phillips screwdriver to securely tighten the fixing screw.

4. Turn on the power for the projector.

- Carry out the steps in "Changing the fan mode" on the next page.

Attention

- The air filter must be installed before using the projector. If the projector is used without the air filter installed or if it is not inserted securely into the projector as far as it will go, foreign particles and dust will get inside the projector and cause problems with operation.

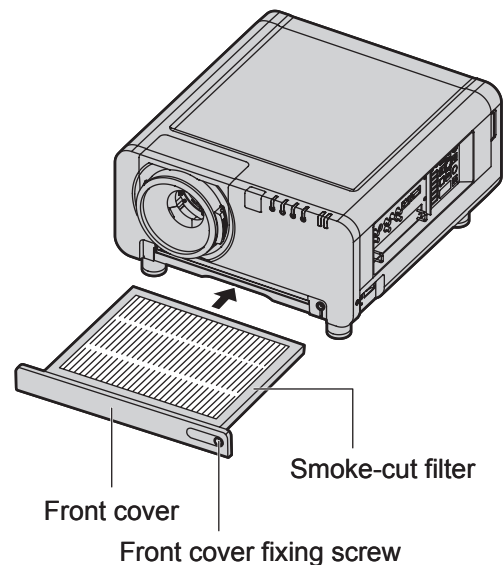

Note

- This filter can be used for approximately 24 hours in smoky environments. If it is used for more than approximately 24 hours, operating problems may occur.
- Do not wash the static electric mesh filter with water.
- Do not reuse.
- This filter will not remove 100 % of the smoke from the air. If the projector is used repeatedly in a smoky environment, it may require inspection or repairs.

Changing the fan mode

1. Press MENU.

- The "MAIN MENU" appears on the screen.

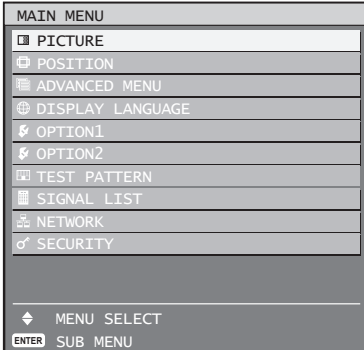

2. Press ▲ ▼ to select "OPTION2".

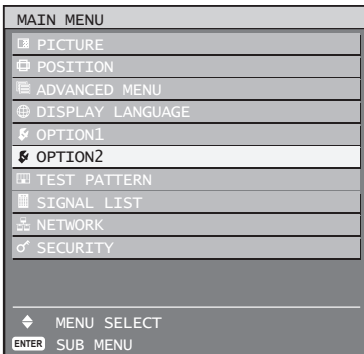

3. Press ENTER.

- The "OPTION2" menu appears on the screen.



4. Press ▲ ▼ to select "PASSWORD".

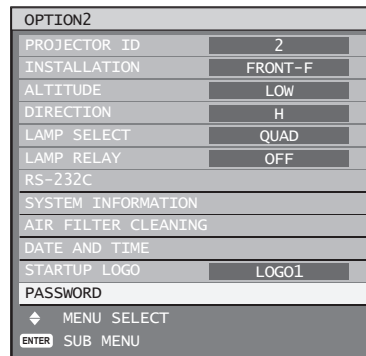

5. Press ENTER.

- The "PASSWORD" menu appears on the screen.

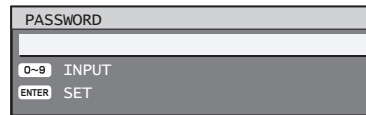

6. Enter "1111" using the remote control, and then press ENTER.

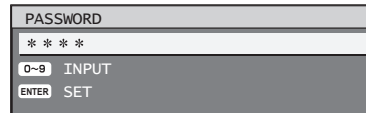

7. Press ◀ ▶ to select "SPECIAL".



8. Press MENU to exit the menu screen.

Note

- The above setting will cause the fan speed to increase.
- "U75" will appear in the self-diagnosis display at the control panel.
- When you have finished using the smoke-cut filter and it has been replaced with the projector's built-in filter cleaning unit, change the setting in step 7 above to "NORMAL" and check that "U75" no longer appears in the self-diagnosis display at the control panel.
- The above display may vary depending on the software version for the projector. ("U70" may appear in the self-diagnosis display on the operation panel.)
If the display is different, check while referring to "Checking the software version" on the next page.

Checking the software version

1. Press STATUS on the remote control.

STATUS
INPUT : RGB1
: 0.00kHz/ 0.00Hz
PROJECTOR RUNTIME : 13h
LAMP1 : 9h/OFF/
LAMP2 : 10h/OFF/
LAMP3 : 9h/OFF/
LAMP4 : 9h/ON/
TEMP : IN- 27 / OUT- 32 /OPT- 36
VERSION MAIN : 0.55
VERSION NETWORK : 0.09
REMOTE2 : DISABLE
ENTER END STATUS VIA E-MAIL

- You can check the software version under “Main” in the status menu window.
- If the version is 1.12 or earlier, contact the following to have the main ROM version upgraded.

Matsushita Electric Industrial Co., Ltd

Web Site : <http://www.panasonic.co.jp/global/>

© 2007 Matsushita Electric Industrial Co., Ltd. All Rights Reserved.