

Bracket assembly

Description

This bracket assembly is used when mounting a Panasonic's applicable projector to ceilings.

NOTE: This ceiling mount bracket cannot be used by itself. Combine it with the optional ceiling mount bracket.

Specifications

Dimensions (W × H × D):	199 × 54.5 × 246 mm (7-27/32 × 2-5/32 × 9-11/16 inches)
Weight:	Approx. 2.6 kg* (5.7 lbs*)
Applicable ceiling mount bracket:	ET-PKV100H/PKV100S
Applicable projector:	PT-CW331R/CW330/CW241R/CW240/CX301R/CX300

* Average value. May differ depending on models.

Parts

Projector mount bracket (bracket assembly)	1	Washer-fitted hexagonal bolts (M6 × 18)	1
Washer-fitted screws (M4 × 10)	11	Safety wire	1

Caution:

- Mounting should be done by a qualified technician.
- Make sure that the mounting (ceiling) area has sufficient strength.
- Read the enclosed mounting instructions thoroughly before starting.
- Do not use an electric screwdriver or impact driver to tighten screws. Use a torque driver or hexagon torque wrench and tighten screws to the torque specified in the instructions.
- When the product is no longer going to be used, have it disposed of quickly by a professional disposal service.

Dimensions

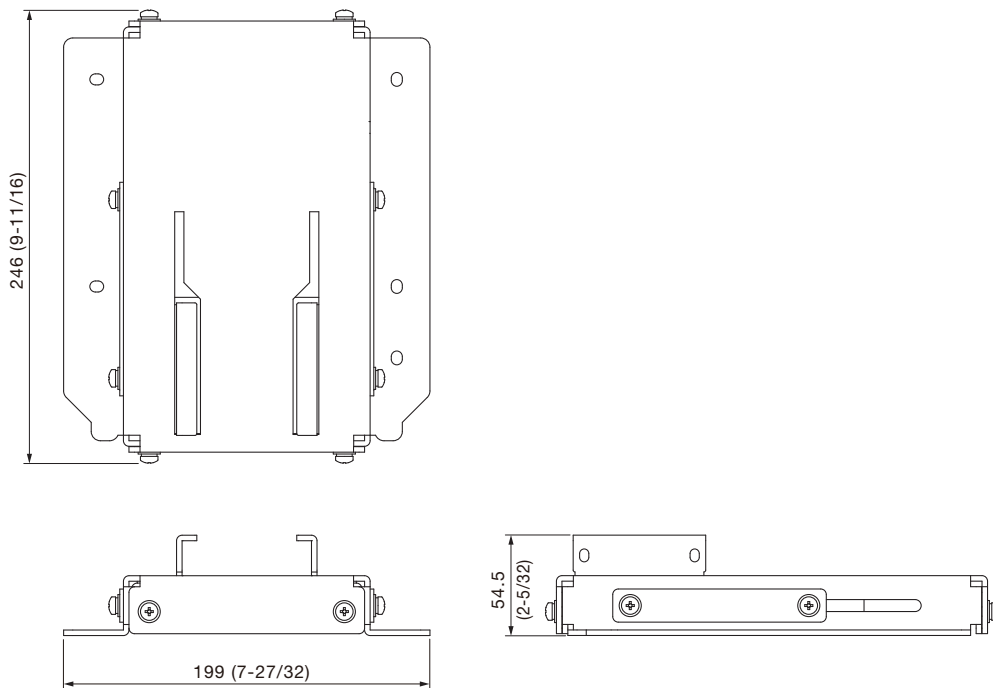

unit : mm (inch)
NOTE: This illustration is not drawn to scale.

Weights and dimensions shown are approximate. Specifications and appearance are subject to change without notice.