



## Specifications

Power supply		100–240 V AC, 50/60 Hz
Power consumption		290 W (approx. 0.3 W at 100–120V AC, approx. 0.4 W at 220–240 V with standby mode set to eco* <sup>1</sup> , approx. 15 W with standby mode set to normal, approx. 18 W in normal standby mode when set to audio monitor out.)
Optical system		Dichroic mirror separation/prism synthesis system
LCD panel	Panel size	16 mm (0.63") diagonal (4:3 aspect ratio)
	Display method	Transparent LCD panel (× 3, R/G/B)
	Drive method	Active matrix
	Pixels	786,432 (1,024 × 768) × 3, total of 2,359,296 pixels
	Pixel configuration	Stripe
Lens		Manual zoom (1:1–1:1.2), manual focus F 2.00–2.20, f 19.22–22.68 mm
Lamp		220 W UHM lamp
Projection size		838–7,620 mm (33–300 inches) diagonally, 4:3 aspect ratio
Colors		Full color (16,777,216 colors)
Brightness* <sup>2</sup>		2,600 lumens
Center-to-corner uniformity ratio* <sup>2</sup>		85%
Contrast ratio* <sup>2</sup>		600:1 (full on/full off)
Resolution RGB		1,024 × 768 pixels (Input signals that exceed this resolution will be converted to 1,024 × 768 pixels.)
Scanning frequency	RGB	Horizontal: 15.00 kHz–91.00 kHz, Vertical: 50 Hz–85 Hz
	YPbPr	480i (525i): f <sub>H</sub> 15.75 kHz; f <sub>V</sub> 60 Hz 576i (625i): f <sub>H</sub> 15.63 kHz; f <sub>V</sub> 50 Hz 480p (525p): f <sub>H</sub> 31.50 kHz; f <sub>V</sub> 60 Hz 576p (625p): f <sub>H</sub> 31.25 kHz; f <sub>V</sub> 50 Hz 720 (750)/60p: f <sub>H</sub> 45.00 kHz; f <sub>V</sub> 60 Hz 720 (750)/50p: f <sub>H</sub> 37.50 kHz; f <sub>V</sub> 50 Hz 1080 (1125)/60i: f <sub>H</sub> 33.75 kHz; f <sub>V</sub> 60 Hz 1080 (1125)/50i: f <sub>H</sub> 28.13 kHz; f <sub>V</sub> 50 Hz 1080 (1125)/60p: f <sub>H</sub> 67.50 kHz; f <sub>V</sub> 60 Hz 1080 (1125)/50p: f <sub>H</sub> 56.25 kHz; f <sub>V</sub> 50 Hz
	Video/S-Video	f <sub>H</sub> : 15.75 kHz, f <sub>V</sub> : 60 Hz [NTSC/NTSC4.43/PAL-M/PAL60] f <sub>H</sub> : 15.63 kHz, f <sub>V</sub> : 50 Hz [PAL/SECAM/PAL-N] 5:1 (fixed)
Optical axis shift		Approx. ±30° vertically
Keystone correction range		17 languages: English, French, German, Spanish, Italian, Korean, Russian, Chinese, Japanese, Swedish, Norwegian, Danish, Portuguese, Polish, Hungarian, Czech, and Thai
On-screen menu		Front/rear, ceiling/desk (menu selection)
Installation		
Built-in speakers	Size	4 × 2 cm (oval) × 1, 1.0 W (monaural)
Terminals	Output power	
	COMPUTER (RGB) IN	D-sub HD 15-pin (female) × 2
	RGB	G: 0.7 V <sub>p-p</sub> (1.0 V [p-p] for sync on green signals), 75 ohms, R, B: 0.7 V <sub>p-p</sub> , 75 ohms, HD/SYNC, VD: TTL (positive/negative polarity compatible)
	YPbPr (YCbCr)	Y: 1.0 V <sub>p-p</sub> (including sync signal), 75 ohms, PbPr/CbCr: 0.7 V <sub>p-p</sub> , 75 ohms
	VIDEO IN	RCA pin × 1, 1.0 V <sub>p-p</sub> , 75 ohms
	S-VIDEO IN	Mini DIN 4-pin × 1, Y: 1.0 V <sub>p-p</sub> , C: 0.286 V <sub>p-p</sub> , 75 ohms
	AUDIO IN	M3 (L, R) × 2, 0.5 V <sub>rms</sub>
	AUDIO OUT	M3 (L, R) × 1, 0–2.0 V <sub>rms</sub> (variable)
	SERIAL	D-sub 9-pin × 1, for external control (RS-232C compliant)
	LAN	RJ-45 × 1 for network connection, compliant with PLink™, 100Base-TX/10Base-T
Power cord length		2 m (6.6 ft)
Cabinet material		Molded plastic (PC+ABS)

Dimensions (W × H × D)		307 × 69 × 210 mm (12-3/32" × 2-23/32" × 8-9/32")*3
Weight		Approx. 2.3 kg (5.1 lbs.)*4
Operating environment	Temperature	0°–40°C (32°–104°F)*5
	Humidity	20%–80% (no condensation)
Remote control unit	Power supply	3 V DC (R03/AAA type battery × 2)
	Operation range	Approx. 7 m (23 ft) when operated from directly in front of the signal receptor
	Dimensions (W × H × D)	46 × 115 × 21 mm (1-13/16" × 4-17/32" × 27/32")
	Weight	Approx. 64 g (2.3 oz) (including batteries)
	Supplied accessories	Power cord (× 1) Power cord secure lock (× 1) Wireless remote control (× 1) Batteries for remote control (R03/AAA type × 2) VGA cable for RGB signals (1.8 m (5 ft 11 in) × 1) Carrying bag (× 1) Software CD-ROM (Logo Transfer Software, Multi Projector Monitoring and Control Software) (× 1)
Optional accessories		Ceiling mount bracket: ET-PKB2 Highly durable filter unit: ET-KFB2 Replacement lamp unit: ET-LAB2 Replacement air filter for ET-KFB2: ET-RFB2

Weights and dimensions shown are approximate. Specifications and appearance are subject to change without notice.

\*1: When the standby mode is set to eco, LAN-based network functions such as the standby on function will not operate and only certain commands can be received from RS-232C control.

\*2: Measurement, measuring conditions, and method of notation all comply with ISO 21118 international standards.

\*3: Protruding parts not included.

\*4: Average value. May differ depending on models.

\*5: The operating temperature range is 0°C to 35°C (32°F to 95°F) when used in High-Altitude mode (1,400 m to 2,700 m (4,593 ft to 8,858 ft)). Also, if the ambient temperature exceeds 35°C (95°F) (30°C (86°F) in High-Altitude mode) when the lamp power mode is set to NORMAL, the light output may be reduced approximately 30% to protect the projector.

Dimensions

unit : mm (inch)

NOTE: This illustration is not drawn to scale.

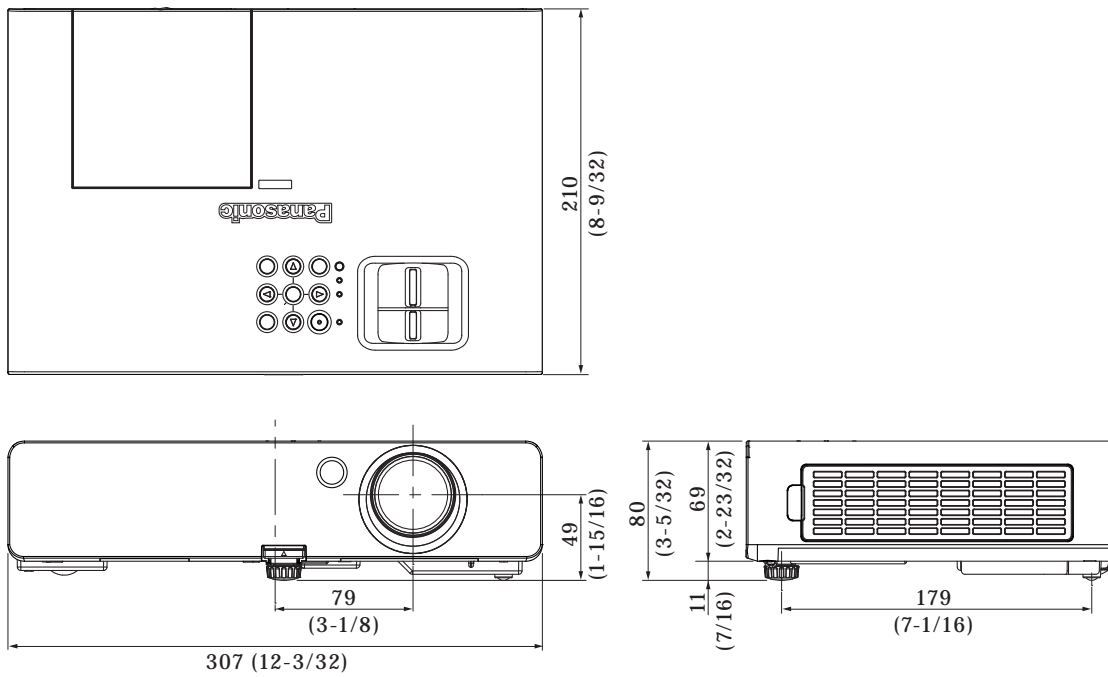

Terminals

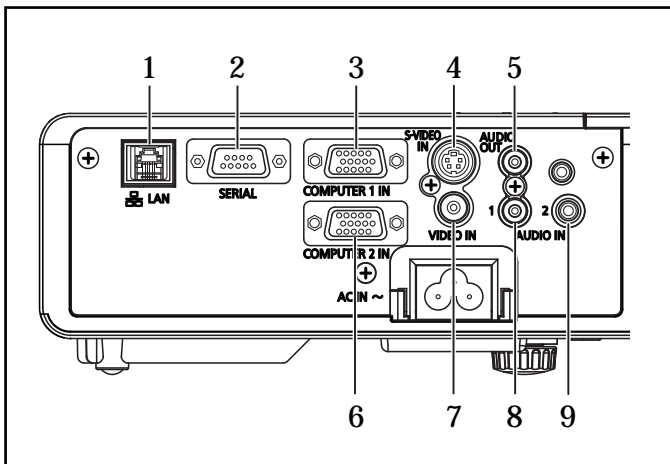

- 1 LAN connector
- 2 Serial input
- 3 Computer 1 input
- 4 S-Video input
- 5 Audio output
- 6 Computer 1 input
- 7 Video input
- 8 Audio 1 input
- 9 Audio 2 input

Standard setting-up positions

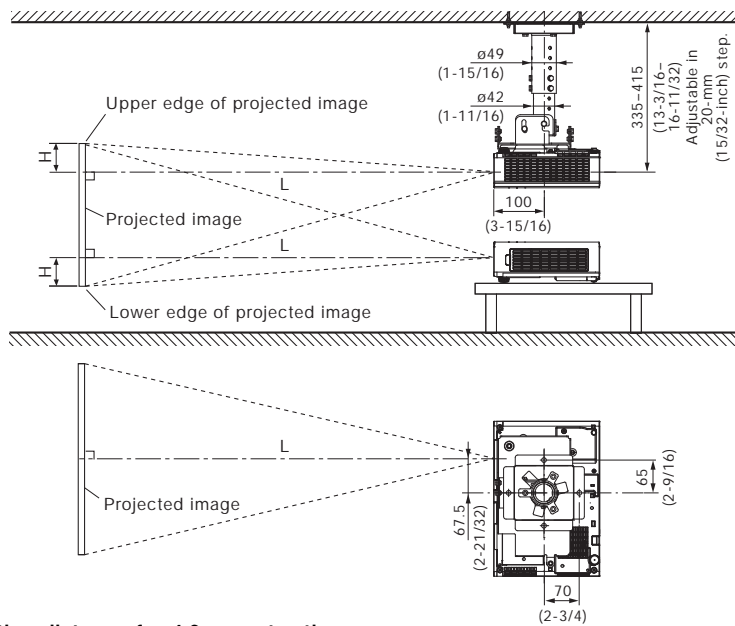

unit : mm (inch)

L: Distance to screen  
H: Height from the edge of screen to center of lens

NOTE:  
Illustrations show the projector installed using optional ceiling mount bracket.  
This illustration is not drawn to scale.

Projection distance for 4:3 aspect ratio screen

Projection size [diagonal]	Projection distance (L)		Height from the edge of screen to center of lens [H]
	Min [wide]	Max [telephoto]	
0.84 m (33")	- (-)	1.1 m (3.8')	0.08 m (0.28')
1.02 m (40")	1.2 m (3.9')	1.4 m (4.6')	0.10 m (0.33')
1.27 m (50")	1.5 m (4.8')	1.8 m (5.8')	0.13 m (0.42')
1.52 m (60")	1.8 m (5.8')	2.1 m (6.9')	0.15 m (0.50')
1.78 m (70")	2.1 m (6.8')	2.5 m (8.1')	0.18 m (0.58')
2.03 m (80")	2.4 m (7.8')	2.8 m (9.3')	0.20 m (0.67')
2.29 m (90")	2.7 m (8.8')	3.2 m (10.5')	0.23 m (0.75')
2.54 m (100")	3.0 m (9.8')	3.5 m (11.6')	0.25 m (0.83')
3.05 m (120")	3.6 m (11.8')	4.3 m (14.0')	0.30 m (1.00')
3.81 m (150")	4.5 m (14.8')	5.3 m (17.5')	0.38 m (1.25')
5.08 m (200")	6.0 m (19.7')	7.1 m (23.4')	0.51 m (1.67')
6.35 m (250")	7.5 m (24.7')	8.9 m (29.3')	0.64 m (2.08')
7.62 m (300")	9.0 m (29.6')	10.7 m (35.1')	0.76 m (2.50')

\* This distance is especially recommended for ceiling-mounted use and other permanent installations.

NOTE:  
Values shown are approximate.  
The value for L (distance to screen) varies slightly depending on the zoom lens characteristics.  
When the shortest projection distance is used, a small amount of distortion may occur in the image due to the zoom lens characteristics.

Calculation of the projection distance

For a screen size different from the above, use the equation below to calculate the projection distance.

- Aspect ratio 4 : 3
  - minimum L (m) = (diagonal screen size in inches) × 0.0302 - 0.035
  - maximum L (m) = (diagonal screen size in inches) × 0.0358 - 0.035
- Aspect ratio 16 : 9
  - minimum L (m) = (diagonal screen size in inches) × 0.0330 - 0.041
  - maximum L (m) = (diagonal screen size in inches) × 0.0391 - 0.040

NOTE: Distances calculated with the above equations will include a slight error.

Installable angle

Install the projector at an angle within the range shown below.

• Vertical direction

The projector may be installed at a vertical angle of ±30°.

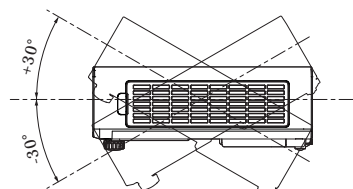

• Horizontal direction

The projector may be installed at a horizontal angle of ±10°.

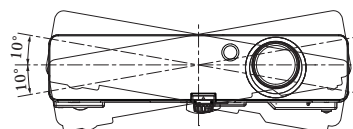

**Computer data compatibility**

This projector accepts up to 91 kHz horizontal scanning frequency and 193 MHz dot clock.

**NOTE:** Pixel thinning is applied to signals that exceed a dot clock frequency of 170 MHz. The display resolution of this projector is 1,024 × 768 pixels. Input signals that exceed this resolution will be converted to 1,024 × 768 pixels.

**List of compatible signals**

Display mode	Display resolution (dots) <sup>1</sup>	Scanning frequency		Dot clock frequency (MHz)	Picture quality <sup>2</sup>	Input terminal
		H (kHz)	V (kHz)			
NTSC/NTSC4.43/PAL-M/PAL60	720 × 480i	15.7	59.9	–	A	VIDEO/S-VIDEO
PAL/PAL-N/SECAM	720 × 576i	15.6	50.0	–	A	
525i (480i)	720 × 480i	15.7	59.9	13.5	A	COMPUTER (RGB/YPbPr)
625i (576i)	720 × 576i	15.6	50.0	13.5	A	
525p (480p)	720 × 483	31.5	59.9	27.0	A	
625p (576p)	720 × 576	31.3	50.0	27.0	A	
750 (720)/60p	1280 × 720	45.0	60.0	74.3	A	
750 (720)/50p		37.5	50.0	74.3	A	
1125 (1080)/60i	1920 × 1080i	33.8	60.0	74.3	A	
1125 (1080)/50i		28.1	50.0	74.3	A	
1125 (1080)/60p	1920 × 1080	67.5	60.0	148.5	A	
1125 (1080)/50p		56.3	50.0	148.5	A	
VESA70	640 × 400	31.5	70.1	25.2	A	COMPUTER (RGB only)
VESA85		37.9	85.1	31.5	A	
VGA60	640 × 480	31.5	59.9	25.2	A	
VGA65		35.0	66.7	30.2	A	
VGA72		37.9	72.8	31.5	A	
VGA75		37.5	75.0	31.5	A	
VGA85		43.3	85.0	36.0	A	
SVGA55	800 × 600	35.2	56.3	36.0	A	
SVGA60		37.9	60.3	40.0	A	
SVGA70		48.1	72.2	50.0	A	
SVGA75		46.9	75.0	49.5	A	
SVGA85		53.7	85.1	56.3	A	
MAC16	832 × 624	49.7	74.6	57.3	A	
XGA50	1024 × 768	39.6	50.1	51.9	AA	
XGA60		48.4	60.0	65.0	AA	
XGA70		56.5	70.1	75.0	AA	
XGA75		60.0	75.0	78.8	AA	
XGA85		68.7	85.0	94.5	AA	
WIDE750 (720)	1280 × 720	44.8	59.9	74.5	A	
		37.1	49.8	60.5	A	
WXGA768	1280 × 768	39.6	49.9	65.3	A	
		47.8	59.9	79.5	A	
WXGA800	1280 × 800	41.3	50.0	68.0	A	
		49.1	60.2	69.1	A	
		49.7	59.8	83.5	A	
MXGA70	1152 × 864	64.0	71.2	94.2	A	
MXGA75		67.5	74.9	108.0	A	
MXGA85		76.7	85.0	121.5	A	
MAC21	1152 × 870	68.7	75.1	100.0	A	
MSXGA60	1280 × 960	60.0	60.0	108.0	A	
SXGA60	1280 × 1024	64.0	60.0	108.0	A	
SXGA75		80.0	75.0	135.0	A	
SXGA85		91.1	85.0	157.5	A	
SXGA60+	1400 × 1050	64.0	60.0	108.0	A	
		65.1	59.9	122.4	A	
WXGA+	1440 × 900	55.9	59.9	106.5	A	
UXGA60	1600 × 1200	75.0	60.0	162.0	A	
WSXGA+	1680 × 1050	65.3	60.0	146.3	A	
WUXGA	1920 × 1200	74.6	59.9	193.3	B	

1. The “i” appearing after the resolution indicates an interlaced signal.

2. The following symbols are used to indicate picture quality.

**AA** Maximum picture quality can be obtained.

**A** Signals are converted by the image processing circuit before picture is projected.

**B** Signals are compressed by the image processing circuit before picture is projected.

**Serial connector**

The serial connector complies with RS-232C. To control the projector from a personal computer, commands must be input through communication software, based on the format and satisfying the communication conditions shown below.

**Pin assignments and signal names**

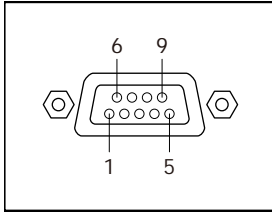

D-sub HD 9-pin, female

No.	Signal name	Description	No.	Signal name	Signal name
1	-	NC	6	-	Connected internally
2	TXD	Send data	7	CTS	Connected internally
3	RXD	Receive data	8	RTS	Connected internally
4	-	NC	9	-	NC
5	GND	Ground			

**Communication conditions (factory setting)**

Signal level	RS-232C-compliant
Synchronization method	Start-stop synchronization
Baud rate	9,600 bps
Parity	None
Character length	8 bits
Stop bit	1 bit
X parameter	None
S parameter	None

**Basic format**

Transmission from the computer begins with STX, then the ID, command, parameter, and ETX are sent in this order. Add parameters according to the details of control.

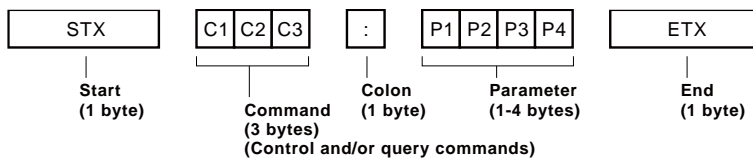

**NOTE**

- If a wrong command is received, the projector will send an ER401 command to the computer.
- If a wrong parameter is received, the projector will send an ER402 command to the computer.

**CAUTION**

- It may not be possible to send or receive commands for about 10 to 60 seconds when the lamp is first turned on. If this occurs, wait for 60 seconds, then try sending or receiving again.
- When sending multiple commands, be sure to wait for at least 0.5 second after receiving a response from the projector before sending the next command.
- Additional time is sometimes required for response due to processing inside the projector. Set the time-out period for command response to 10 seconds or more.

**Cable specifications**

Projector		PC (DTE)	
1	NC	NC	1
2			2
3			3
4	NC	NC	4
5			5
6	NC	NC	6
7			7
8			8
9	NC	NC	9

## Control commands

Command: <Parameter>	Function	Callback: <Parameter>	Parameter value	
			Min	Max
PON*1/*2	Power on (standby mode on)	PON	-	-
POF*1/*2	Power off (standby mode off)	POF	-	-
AVL:<p1>	Volume control	AVL:<p1>	0	63
IIS:<input signal>	Input signal selection	IIS:<input signal>	-	-
OST	The same function as "default" button	OST	-	-
OFZ:<off on>	Freeze	OFZ:<off on>	0	1
OEN	Enter	OEN	-	-
OXG:0	Wide mode: Off	OXG:0	-	-
OXG:1	Wide mode: On	OXG:1	-	-
OXG:2	Wide mode: Auto	OXG:2	-	-
VPM:<NAT>	Picture mode: Natural	VPM:<NAT>	-	-
VPM:<STD>	Picture mode: Standard	VPM:<STD>	-	-
VPM:<DYN>	Picture mode: Dynamic	VPM:<DYN>	-	-
VPM:<BBD>	Picture mode: Blackboard	VPM:<BBD>	-	-
VPM:<WBD>	Picture mode: Whiteboard	VPM:<WBD>	-	-
VXX:DLVI0=<+00000>	Daylight View: Off	VXX:DLVI0=<+00000>	-	-
VXX:DLVI0=<+00001>	Daylight View: Auto	VXX:DLVI0=<+00001>	-	-
VXX:DLVI0=<+00002>	Daylight View: On	VXX:DLVI0=<+00002>	-	-
AUU	Volume up	AUU	-	-
AUD	Volume down	AUD	-	-
OMN	Menu	OMN	-	-
OCU	Cursor up	OCU	-	-
OCD	Cursor down	OCD	-	-
OCL	Cursor left	OCL	-	-
OCR	Cursor right	OCR	-	-
OAS	Auto setup	OAS	-	-
OSH*1	AV mute	OSH	-	-
OIX	Index window	OIX	-	-
DZU	Digital zoom: Enlargement	DZU	-	-
DZD	Digital zoom: Reduction	DZD	-	-

\*1 Do not send PON, POF, or OSH commands continuously in a short period of time (0.5 second or less). Doing so may burst the lamp or shorten the lamp replacement cycle.

\*2 These commands are effective when the standby mode is set to eco. (Other commands are not effective.)



Status request commands

Command	Description	Callback <Parameter>
QPW*	Standby power status	<power condition>
Q\$S*	Lamp status	<lamp condition>
QIN	Input signal status	<input signal>
QAV	Volume adjustment value	<p1>
QVC	Color adjustment value	<p1>
QVT	Tint adjustent value	<p1>
QVB	Brightness adjustment value	<p1>
QVR	Contrast adjustment value	<p1>
QVS	Sharpness adjustment value	<p1>
QWR	White balance: R adjustment value	<p1>
QWG	White balance: G adjustment value	<p1>
QWB	White balance: B adjustment value	<p1>
QHP	Horizontal position adjustment value	<p1>
QVP	Vertical position adjustment value	<p1>
QCP	Clock phase adjustment value	<p1>
QDC	Dot clock adjustment value	<p1>
QSP	Projection method status	<p1>
QLG	On-screen menu language	<p1>
QXG	Wide mode status	Off <0>
		On <1>
		Auto <2>
QVX:DLVIO	Daylight View status	Off <+00000>
		Auto <+00001>
		On <+00002>
QPM	Picture mode status	Natural <NAT>
		Standard <STD>
		Dynamic <DYN>
		Blackboard <BBD>
	Whiteboard <WBD>	
QFZ	Freeze status	<off_on>
Q\$L	Lamp run time	<acctch>
QSH	AV mute	<off_on>
QKS	Keystone correction status	<p1>
QTE	Color temperature adjustment status	<color temp>

\* These commands can be operated in standby mode eco. Other commands shown can not be operated in standby mode eco.

Parameter format

Parameter format	Size (Byte)	Definition
<p1>	3 (1 or 2 bytes also possible when under control)	Decimal without signs: 0 to 999 (000, 001, 002...999) Decimal with signs: -99 to +99 (-99...-01, +00, +01, +02...+99) Callback from the projector is 3 Byte.
<off on>	1	0 = off, 1 = on
<input signal>	3	RG1 = computer 1, RG2 = computer 2, VID = video, SVD = S-Video
<power condition>	3	000 = power off (standby mode off), 001 = power on (standby mode on)
<lamp condition>	1	0 = standby, 1 = lamp on under control, 2 = lamp on, 3 = lamp off under control
<acctch>	4	Decimal without signs: 0000-9999 hours
<color temp>	1	0 = low, 1 = normal, 2 = high

NOTE: If a wrong command is received, the projector will send an ER401 command to the computer.

Command example

To set the volume to +30, send the command as shown right.



NOTE: When sending commands without parameters, a colon (:) is not necessary.

**Notes on projector placement and operation**

The projector uses a high-wattage lamp that becomes very hot during operation. Please observe the following precautions.

1. Never place objects on top of the projector.
2. Make sure there is an unobstructed space of 500 mm (19-11/16") or more around the projector's exhaust openings. Also, make sure there is an efficient space for replacing lamp units or detaching or attaching the air filter.
3. Make sure that nothing blocks the projector's air intake and exhaust openings. Also, install the projector so that cool or hot air from other air conditioning equipment does not flow directly toward the projector's air intake or exhaust openings.
4. Do not install the projector in an enclosed space. If it is necessary to install it in an enclosed space, add a separate ventilation system. If ventilation is insufficient, hot air will accumulate at the intake opening. This may cause the projector's protective circuit to interrupt projector operation.

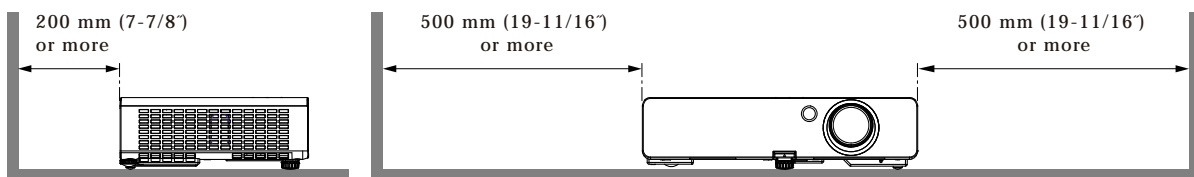

**Direction of air intake and exhaust**

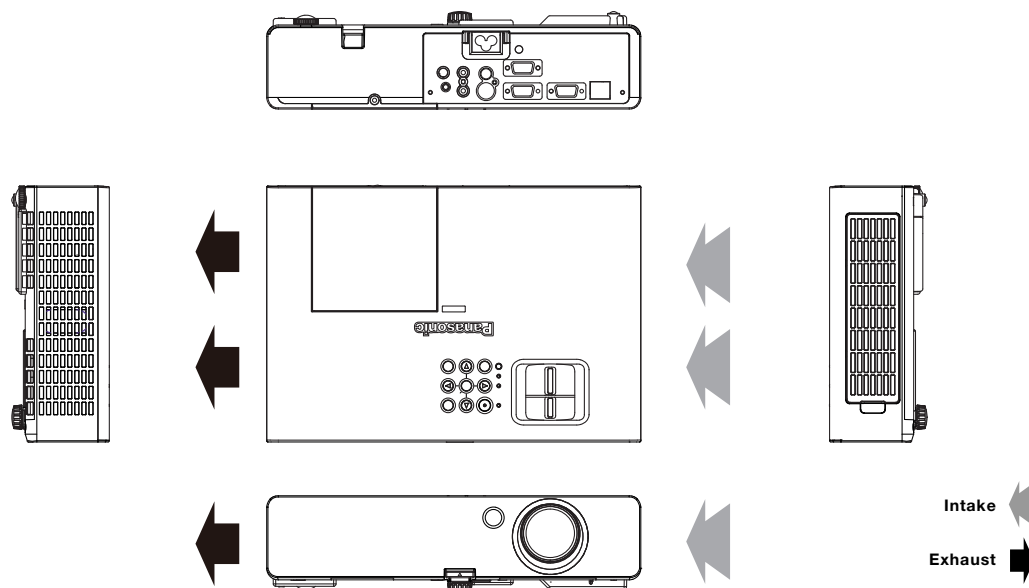

**Operating the projector continuously**

1. If the projector is to be operated continuously 10 hours or more, lamp replacement cycle duration becomes shorter.
2. The lamp replacement cycle duration becomes shorter if the projector is operated repeatedly for short periods (one hour or less).

Weights and dimensions shown are approximate. Specifications and appearance are subject to change without notice. PJLink is a registered trademark, or a trademark application has been filed, in Japan, the United States, and other countries and regions. This product may be subject to export control regulations. All other trademarks are the property of their respective trademark owners.