

# Panasonic®

## Owner's Manual

4K Video Camera

Model No. **HC-X1500**  
**HC-X2000**

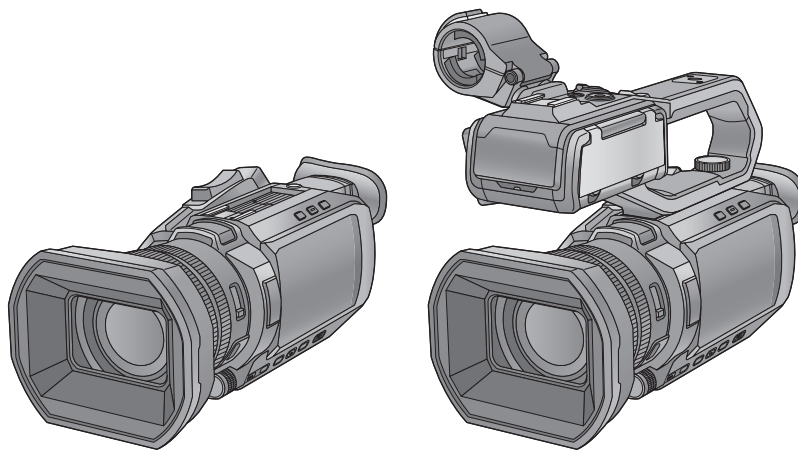

Please read these instructions carefully before using this product, and save this manual for future use.

A firmware update has been made available to improve camera capabilities and to add functionality.

- For information about functions that have been added or modified, refer to the pages for "[Firmware Update](#)".

**AVCHD™**  
Progressive

**DOLBY AUDIO™**

LEICA  
DICOMAR

**WiFi®**  
**CERTIFIED**



**HDMI™**

**SD™ U3 I**  
**XC I**

Register online at <http://shop.panasonic.com/support/register> (U.S. customers only)

If you have any questions, visit :

U.S.A. : <http://shop.panasonic.com/support>

Canada : [www.panasonic.ca/english/support](http://www.panasonic.ca/english/support)

# Safety Precautions

**Dear Customer,**

**Thank you for choosing Panasonic!**

You have purchased one of the most sophisticated and reliable products on the market today. Used properly, we're sure it will bring you and your family years of enjoyment. Please take time to fill in the information on the right.

The serial number is on the tag located on the back of your camera. Be sure to **retain this manual** as your convenient camera information source.

Date of Purchase	_____
Dealer Purchased From	_____
Dealer Address	_____
Dealer Phone No.	_____
Model No.	_____
Serial No.	_____

**U.S.A./CANADA CONSUMERS: ATTENTION:**



A lithium ion battery that is recyclable powers the product you have purchased. Please call 1-800-8-BATTERY for information on how to recycle this battery.

## WARNING:

To reduce the risk of fire, electric shock or product damage,

- Do not expose this unit to rain, moisture, dripping or splashing.
- Do not place objects filled with liquids, such as vases, on this unit.
- Use the recommended accessories.
- Do not remove covers.
- Do not repair this unit by yourself. Refer servicing to qualified service personnel.

## CAUTION!

To reduce the risk of fire, electric shock or product damage,

- Do not install or place this unit in a bookcase, built-in cabinet or in another confined space. Ensure this unit is well ventilated.
- Do not obstruct this unit's ventilation openings with newspapers, tablecloths, curtains, and similar items.
- Do not place sources of naked flames, such as lighted candles, on this unit.

### Certification and Compliance

See Camera for the certification and compliance mark specific to that device.

- 1 Press the <MENU> button.
- 2 Select the [OTHERS] menu.
- 3 Select the [APPROVED REGULATION] menu.

**THE FOLLOWING APPLIES ONLY IN THE U.S.A.**

**FCC Note:**

This equipment has been tested and found to comply with the limits for a Class B digital device, pursuant to Part 15 of the FCC Rules. These limits are designed to provide reasonable protection against harmful interference in a residential installation. This equipment generates, uses, and can radiate radio frequency energy and, if not installed and used in accordance with the instructions, may cause harmful interference to radio communications. However, there is no guarantee that interference will not occur in a particular installation. If this equipment does cause harmful interference to radio or television reception, which can be determined by turning the equipment off and on, the user is encouraged to try to correct the interference by one or more of the following measures:

- Reorient or relocate the receiving antenna.
- Increase the separation between the equipment and receiver.
- Connect the equipment into an outlet on a circuit different from that to which the receiver is connected.
- Consult the dealer or an experienced radio/TV technician for help.

**FCC Caution:**

- Any unauthorized changes or modifications to this equipment would void the user's authority to operate this device.
- To assure continued compliance, follow the attached installation instructions and use only shielded interface cables when connecting to computer or peripheral devices.

This device complies with Part 15 of the FCC Rules. Operation is subject to the following two conditions: (1) This device may not cause harmful interference, and (2) this device must accept any interference received, including interference that may cause undesired operation.

**Supplier's Declaration of Conformity**

Trade Name: Panasonic  
Model No.: HC-X1500/HC-X2000  
Responsible Party: Panasonic Corporation of North America  
Two Riverfront Plaza, Newark, NJ 07102-5490  
Support Contact: <http://shop.panasonic.com/support>



**THE FOLLOWING APPLIES ONLY IN CANADA.**

CAN ICES-3(B)/NMB-3(B)

**THE FOLLOWING APPLIES ONLY IN THE U.S.A.**

**Contains FCC ID: VPYLB1JS955**

This transmitter must not be co-located or operated in conjunction with any other antenna or transmitter.

This equipment complies with FCC radiation exposure limits set forth for an uncontrolled environment and meets the FCC radio frequency (RF) Exposure Guidelines as this equipment has very low levels of RF energy.

**Compliance with FCC requirement 15.407(c)**

Data transmission is always initiated by software, which is then passed down through the MAC, through the digital and analog baseband, and finally to the RF chip. Several special packets are initiated by the MAC. These are the only ways the digital baseband portion will turn on the RF transmitter, which it then turns off at the end of the packet. Therefore, the transmitter will be on only while one of the aforementioned packets is being transmitted. In other words, this device automatically discontinues transmission in case of either absence of information to transmit or operational failure.

Frequency Tolerance:  $\pm 20\text{ppm}$

**THE FOLLOWING APPLIES ONLY IN CANADA.**

**Contains IC: 772C-LB1JS955**

This device contains licence-exempt transmitter(s)/receiver(s) that comply with Innovation, Science and Economic Development Canada's licence-exempt RSS(s). Operation is subject to the following two conditions:

1. This device may not cause interference.
2. This device must accept any interference, including interference that may cause undesired operation of the device.

The available scientific evidence does not show that any health problems are associated with using low power wireless devices. There is no proof, however, that these low power wireless devices are absolutely safe. Low power Wireless devices emit low levels of radio frequency energy (RF) in the microwave range while being used. Whereas high levels of RF can produce health effects (by heating tissue), exposure of low-level RF that does not produce heating effects causes no known adverse health effects. Many studies of low-level RF exposures have not found any biological effects. Some studies have suggested that some biological effects might occur, but such findings have not been confirmed by additional research. HC-X2000/HC-X1500 (HMN is 1JS2099) has been tested and found to comply with ISED radiation exposure limits set forth for an uncontrolled environment and meets RSS-102 of the ISED radio frequency (RF) Exposure rules.

## **IMPORTANT SAFETY INSTRUCTIONS**

Read these operating instructions carefully before using the unit. Follow the safety instructions on the unit and the applicable safety instructions listed below. Keep these operating instructions handy for future reference.

- 1) Read these instructions.
- 2) Keep these instructions.
- 3) Heed all warnings.
- 4) Follow all instructions.
- 5) Do not use this apparatus near water.
- 6) Clean only with dry cloth.
- 7) Do not block any ventilation openings. Install in accordance with the manufacturer's instructions.
- 8) Do not install near any heat sources such as radiators, heat registers, stoves, or other apparatus (including amplifiers) that produce heat.
- 9) Do not defeat the safety purpose of the polarized or grounding-type plug. A polarized plug has two blades with one wider than the other. A grounding-type plug has two blades and a third grounding prong. The wide blade or the third prong are provided for your safety. If the provided plug does not fit into your outlet, consult an electrician for replacement of the obsolete outlet.
- 10) Protect the power cord from being walked on or pinched particularly at plugs, convenience receptacles, and the point where they exit from the apparatus.
- 11) Only use attachments/accessories specified by the manufacturer.
- 12) Use only with the cart, stand, tripod, bracket, or table specified by the manufacturer, or sold with the apparatus. When a cart is used, use caution when moving the cart/apparatus combination to avoid injury from tip-over.
- 13) Unplug this apparatus during lightning storms or when unused for long periods of time.
- 14) Refer all servicing to qualified service personnel. Servicing is required when the apparatus has been damaged in any way, such as power-supply cord or plug is damaged, liquid has been spilled or objects have fallen into the apparatus, the apparatus has been exposed to rain or moisture, does not operate normally, or has been dropped.



■ **Concerning the AC adaptor**

**AC adaptor**

This AC adaptor operates on AC between 100 V and 240 V.

But

- In the U.S.A. and Canada, the AC adaptor must be connected to a 120 V AC power supply only.
- When connecting to an AC supply outside of the U.S.A. or Canada, use a plug adaptor to suit the AC outlet configuration.
- When connecting to a supply of greater than AC 125V, ensure the cord you use is suited to the voltage of the AC supply and the rated current of the AC adaptor.
- Contact an electrical parts distributor for assistance in selecting a suitable AC plug adaptor or AC cord set.

The power plug is the disconnecting device. Install this unit so that the power plug can be unplugged from the socket outlet immediately.

This unit is intended for use in moderate climates.

■ **Concerning the battery**

**Battery pack (Lithium ion battery pack)**

- Use the specified unit to recharge the battery pack.
- Do not use the battery pack with equipment other than the specified unit.
- Do not get dirt, sand, liquids, or other foreign matter on the terminals.
- Do not touch the plug terminals (+ and –) with metal objects.
- Do not disassemble, remodel, heat or throw into fire.

If any electrolyte should come into contact with your hands or clothes, wash it off thoroughly with water.

If any electrolyte should come into contact with your eyes, never rub the eyes. Rinse eyes thoroughly with water, and then consult a doctor.

**Warning**

Risk of fire, explosion and burns. Do not disassemble, heat above 60 °C (140 °F) or incinerate.

**CAUTION**

- Danger of explosion if battery is incorrectly replaced. Replace only with the type recommended by the manufacturer.
- When disposing of the batteries, please contact your local authorities or dealer and ask for the correct method of disposal.

■ **Product Identification Marking**

Product	Location
4K Video Camera	Bottom
AC adaptor	Bottom

## ■ Cautions for use

**Keep this unit as far away as possible from electromagnetic equipment (such as microwave ovens, TVs, video games etc.).**

- If you use this unit on top of or near a TV, the pictures and/or sound on this unit may be disrupted by electromagnetic wave radiation.
- Do not use this unit near cell phones because doing so may result in noise adversely affecting the pictures and/or sound.
- Recorded data may be damaged, or pictures may be distorted, by strong magnetic fields created by speakers or large motors.
- Electromagnetic wave radiation generated by microprocessors may adversely affect this unit, disturbing the pictures and/or sound.
- If this unit is adversely affected by electromagnetic equipment and stops functioning properly, turn this unit off and remove the battery or disconnect AC adaptor. Then reinsert the battery or reconnect AC adaptor and turn this unit on.

**Do not use this unit near radio transmitters or high-voltage lines.**

If you record near radio transmitters or high-voltage lines, the recorded pictures and/or sound may be adversely affected.

**Do not lift up this unit by the handle with the tripod still attached**

- When the tripod is attached, its weight will also affect the unit's handle, possibly causing the handle to break and hurting the user.
- To carry the unit while the tripod is attached, take hold of the tripod.

**Do not swing the unit around, shake it by, or allow it hang from the handle**

- Do not jar, swing, or shake the unit by its handle. Any strong jolt to the handle may damage the unit or result in personal injury.

**Do not allow the cord to drag on the ground or pull a connected cord along the passage**

- The cord will be damaged, causing fire or electrical shock, when the cord gets caught by the feet, excite will also cause personal injury.

**When this unit is turned on, do not use it in direct contact with the skin for a long period of time.**

- When using this unit for a long period of time, use a support such as a tripod. Low temperature burns may result if any high temperature part of this unit or hot air from the ventilation openings on the front side of the hand strap of this unit is in direct contact with the skin for a long period of time.

**About connecting to a PC**

- A USB2.0 cable is not supplied with this unit. Use a commercially-available generic USB cable conforming to USB2.0. If possible, we recommend using a cable with a length of 1.5 m (approx. 4.9 feet) or less.

**About connecting to a TV**

- Use a commercially-available High Speed HDMI cable. If possible, we recommend using a cable with a length of 3 m (approx. 9.8 feet) or less.

**About using a headphone**

- Excessive sound pressure from earphones and headphones can cause hearing loss.
- Listening at full volume for long periods may damage the user's ears.

## ■ Caution regarding the lens and the viewfinder

Do not aim the lens or the viewfinder at the sun or strong light. Doing so may cause the unit to malfunction.

## ■ Batteries that may be used with this product (As of January 2020)

Panasonic AG-VBR59/VW-VBD58 batteries may be used with this product.

It has been found that counterfeit battery packs which look very similar to the genuine product are made available to purchase in some markets. Some of these battery packs are not adequately protected with internal protection to meet the requirements of appropriate safety standards. There is a possibility that these battery packs may lead to fire or explosion. Please be advised that we are not liable for any accident or failure occurring as a result of use of a counterfeit battery pack. To ensure that safe products are used we would recommend that a genuine Panasonic battery pack is used.

## ■ The symbols on this product (including the accessories) represent the following:

~	AC
===	DC
	ON
⏻	Standby
□	Class II equipment (The construction of the product is double-insulated.)

---

## Trademark

---

- SDXC logo is a trademark of SD-3C, LLC.
- "AVCHD", "AVCHD Progressive" and the "AVCHD Progressive" logo are trademarks of Panasonic Holdings Corporation and Sony Corporation.
- Manufactured under license from Dolby Laboratories. Dolby, Dolby Audio, and the double-D symbol are trademarks of Dolby Laboratories.
- The terms HDMI and HDMI High-Definition Multimedia Interface, and the HDMI Logo are trademarks or registered trademarks of HDMI Licensing Administrator, Inc. in the United States and other countries.
- LEICA is a registered trademark of Leica Microsystems IR GmbH and DICOMAR is a registered trademark of Leica Camera AG.
- Windows® is a registered trademark or trademark of Microsoft Corporation in the United States and/or other countries.
- Screenshots are used according to Microsoft Corporation guidelines.
- Intel® and Intel®Core™ are trademarks of Intel Corporation in the U.S. and/or other countries.
- Mac and macOS are trademarks of Apple Inc. registered in the U.S. and other countries.
- iPhone and iPad are trademarks of Apple Inc. registered in the U.S. and other countries.
- App Store is a service mark of Apple Inc.
- Google, Android and Google Play are trademarks of Google LLC.
- The Wi-Fi CERTIFIED™ Logo is a certification mark of Wi-Fi Alliance®.
- The Wi-Fi Protected Setup™ Logo is a certification mark of Wi-Fi Alliance®.
- "Wi-Fi®" is a registered trademark of Wi-Fi Alliance®.
- "Wi-Fi Protected Setup™", "WPA™", and "WPA2™" are trademarks of Wi-Fi Alliance®.
- All other names, company names, product names, etc., contained in this instruction manual are trademarks or registered trademarks of their respective owners.

---

## License

---

This product is licensed under the AVC Patent Portfolio License for the personal use of a consumer or other uses in which it does not receive remuneration to (i) encode video in compliance with the AVC Standard ("AVC Video") and/or (ii) decode AVC Video that was encoded by a consumer engaged in a personal activity and/or was obtained from a video provider licensed to provide AVC Video. No license is granted or shall be implied for any other use. Additional information may be obtained from MPEG LA, L.L.C.

See <http://www.mpegla.com>

- Separate license contract with MPEG-LA is required to record in a memory card with this product and to distribute that card to end users for a profit. The end user mentioned here indicates a person or organization that handles contents for a personal use.

---

## Software information about this product

---

This product incorporates the following software:

- (1) the software developed independently by or for Panasonic,
- (2) the software owned by third party and licensed to Panasonic,
- (3) the software licensed under the GNU General Public License, Version 2.0 (GPL V2.0),
- (4) the software licensed under the GNU LESSER General Public License, Version 2.1 (LGPL V2.1), and/or
- (5) open source software other than the software licensed under the GPL V2.0 and/or LGPL V2.1.

The software categorized as (3) - (5) are distributed in the hope that it will be useful, but WITHOUT ANY WARRANTY, without even the implied warranty of MERCHANTABILITY or FITNESS FOR A PARTICULAR PURPOSE.

For details, refer to the terms of license that are displayed using the following method:

- 1) Select the [OTHERS.X] menu → [USB DEVICE] → [SERVICE MODE] → [YES].  
Select "LICENSE.TXT" in the external drive recognized by the computer.

At least three (3) years from delivery of this product, Panasonic will give to any third party who contacts us at the contact information provided below, for a charge no more than our cost of physically performing source code distribution, a complete machine-readable copy of the corresponding source code covered under GPL V2.0 or LGPL V2.1, as well as the respective copyright notice thereof.

Contact Information: [oss-cd-request@gg.jp.panasonic.com](mailto:oss-cd-request@gg.jp.panasonic.com)

The source code and the copyright notice are also available for free in our website below.

<https://panasonic.net/cns/oss/index.html>



---

## How to read this document

---

### ■ Models described in this owner's manual

- This document describes the operation of models HC-X1500 and HC-X2000.
- The illustrations of the products, menu screens, etc., may differ from the actual items. Unless specifically stated otherwise, screen depictions and illustrations of the unit are of HC-X2000.
- The functionalities of the models differ. Be aware that the part numbers for the models that support the functions are shown.
- Not all models may be available depending on the region of purchase.
- Model numbers are abbreviated as follows in this owner's manual:

Model number	Abbreviation used in this owner's manual	
HC-X1500		[X1500]
HC-X2000		[X2000]

---

### ■ Conventions used in this manual

- Words and phrases in [ ] brackets indicate content displayed in the LCD monitor.
- Words and phrases in < > brackets indicate design text used on this unit, such as button names.

### ■ Reference pages

- Reference pages in this document are indicated by (→ 00).

### ■ Terminology

- The battery pack is described as “battery”.
- SDHC memory card, and SDXC memory card are referred to as “SD card” or “memory card” unless distinguished otherwise.
- Images created with one recording operation are referred to as a “clip”.



# Contents

<b>Safety Precautions</b> .....	<b>2</b>	<b>Menu settings</b> .....	<b>64</b>
<b>Chapter 1 Overview</b> .....	<b>11</b>	[THUMBNAIL] menu .....	64
<b>Before using the unit</b> .....	<b>12</b>	[CAMERA] menu .....	65
<b>Accessories/Optional accessories</b> .....	<b>15</b>	[SCENE FILE] menu .....	68
Accessories.....	15	[AUDIO] menu .....	73
Optional accessories.....	16	[VIDEO OUT/LCD/VF] menu .....	75
<b>When turning on the power for the first time</b> .....	<b>17</b>	[RECORDING] menu.....	83
[TIME ZONE] .....	17	[NETWORK] menu .....	85
[CLOCK SETTING].....	17	[SYSTEM] menu .....	89
<b>What you can do with this unit</b> .....	<b>18</b>	[OTHERS] menu.....	90
Recording to the memory card.....	18	<b>Factory setting value of the scene file</b> .....	<b>93</b>
Linking to external devices.....	18	[SCENE FILE] menu.....	93
Connecting to the network .....	19	<b>Target items for scene file/setup file/initialization</b> .....	<b>94</b>
<b>Chapter 2 Description of Parts</b> .....	<b>20</b>	[THUMBNAIL] menu .....	94
<b>Main unit</b> .....	<b>21</b>	[CAMERA] menu .....	94
<b>Handle unit ([X2000] supplied, [X1500] optional: VW-HU1)</b> .....	<b>24</b>	[SCENE FILE] menu .....	95
<b>Basic operation</b> .....	<b>26</b>	[AUDIO] menu .....	96
Multidial operation.....	26	[VIDEO OUT/LCD/VF] menu .....	96
Touch operation of the LCD monitor.....	26	[RECORDING] menu.....	98
<b>Chapter 3 Preparation</b> .....	<b>27</b>	[NETWORK] menu .....	98
<b>Power supply</b> .....	<b>28</b>	[SYSTEM] menu .....	98
Attaching and removing the battery .....	28	[OTHERS] menu.....	99
Charging the battery .....	29	<b>Handling setting data</b> .....	<b>100</b>
<b>Attaching accessories</b> .....	<b>31</b>	Scene files .....	100
Adjusting the grip belt .....	31	Setup file.....	102
Attaching the lens hood .....	31	<b>Chapter 5 Shooting</b> .....	<b>103</b>
Attaching the eye cup .....	32	<b>Shooting</b> .....	<b>104</b>
Attaching the handle unit ([X2000] supplied, [X1500] optional) .....	33	Selecting the resolution, codec, and frame rate for recording video .....	105
Attaching the external microphone .....	35	<b>Adjustable settings when shooting</b> .....	<b>108</b>
Attaching a tripod.....	36	Iris .....	108
<b>Turning on/off the power</b> .....	<b>37</b>	Gain .....	109
Turning the unit on and off with the power button.....	37	Super gain .....	109
Turning the unit on and off with the LCD monitor/viewfinder .....	37	AE level (exposure compensation).....	110
<b>Charging the built-in battery</b> .....	<b>37</b>	Brightness adjustment .....	111
<b>Setting the date/time of the internal clock</b> .....	<b>38</b>	Focusing (manual focus) .....	111
<b>Preparing the memory card</b> .....	<b>39</b>	Setting the shutter speed.....	112
Memory cards supported by the unit (As of January 2020) .....	39	Area mode function.....	112
Preventing unintentional erasing.....	40	<b>Adjusting the white and black balance</b> .....	<b>114</b>
Inserting/removing the memory card .....	41	White balance adjustment .....	114
Formatting the memory card.....	41	Black balance adjustment.....	117
Recording time of the memory card.....	42	<b>Using the zoom function</b> .....	<b>118</b>
Handling the recording data.....	44	Adjusting the zoom position.....	118
<b>Setting of time data</b> .....	<b>47</b>	<b>Using the built-in LED light</b> .....	<b>120</b>
Definition of time data .....	47	Adjust the amount of light from the built-in LED light.....	120
User bits settings .....	47	<b>Image quality adjustment</b> .....	<b>121</b>
Setting the time code .....	48	Detail function.....	121
<b>Assigning function to the USER buttons</b> .....	<b>50</b>	Skin tone function .....	121
Functions assigned to USER buttons .....	50	RB gain control function.....	121
Checking the function assigned to the USER buttons .....	52	Chroma setting function .....	121
<b>Adjusting and setting the LCD monitor</b> .....	<b>53</b>	Matrix function .....	121
Using the LCD monitor.....	53	Color correction function.....	122
Adjusting the LCD monitor.....	53	Black control function.....	122
Mirror shooting .....	53	Gamma function .....	122
<b>Adjusting and setting the viewfinder</b> .....	<b>54</b>	Knee function.....	122
Using the viewfinder.....	54	White clip function.....	122
Adjusting the viewfinder .....	54	<b>Flash band compensation (FBC) function</b> .....	<b>123</b>
<b>Tally lamp</b> .....	<b>55</b>	Flash band compensation function settings.....	123
<b>Chapter 4 Operation</b> .....	<b>56</b>	When using the flash band compensation function .....	123
<b>Basic operation of the screen</b> .....	<b>57</b>	<b>Super slow recording function</b> .....	<b>124</b>
Major button operation and screen display .....	57	<b>Audio input</b> .....	<b>125</b>
Major button operation and switching screen .....	58	Switching the audio input.....	125
<b>Operating each screen</b> .....	<b>59</b>	Using the built-in microphone/external microphone (stereo mini jack) .....	125
Camera image screen.....	59	Using audio equipment/external microphone (XLR, 3-pin).....	126
Thumbnail screen .....	59	Adjusting the audio recording level.....	126
Operation icon screen.....	59	Monitoring the audio .....	128
<b>Basic operation of the menu</b> .....	<b>60</b>	Confirming audio input setting .....	128
Configuration of the menu.....	60	<b>Special recording function</b> .....	<b>129</b>
Displaying the menu .....	61	Pre-recording.....	129
Operating the menu .....	62	Relay recording.....	129
Initializing the menu .....	63	Simultaneous recording .....	130
		Background recording.....	131
		Interval recording .....	132
		IR recording .....	133

<b>Convenient shooting functions .....</b>	<b>134</b>	<b>Chapter 10 Notes .....</b>	<b>184</b>
Zebra patterns display .....	134	<b>Frequently asked questions .....</b>	<b>185</b>
Displaying the marker .....	134	Power supply .....	185
Focus assist function .....	135	Battery .....	185
Face detection/tracking AE&AF function .....	138	Memory card .....	185
Optical image stabilizer function .....	138	Indication .....	185
Dynamic range stretcher function .....	139	Shooting .....	186
Time stamp function .....	140	Playback .....	186
Waveform monitor function .....	140	Connections with external devices .....	186
Digital zoom function .....	141	Computers .....	187
Level gauge .....	141	Others .....	187
<b>Operation icon screen display .....</b>	<b>142</b>	<b>Warning system .....</b>	<b>188</b>
Displaying the operation icon screen .....	142	Cases indicated by error messages .....	188
<b>Multi manual function .....</b>	<b>143</b>	<b>Recording function that cannot be used simultaneously .....</b>	<b>192</b>
Displaying the operation icon screen .....	144	<b>Updating the unit's firmware .....</b>	<b>193</b>
Adjusting headphone volume .....	144	<b>Cleaning and storing .....</b>	<b>194</b>
<b>Chapter 6 Playback .....</b>	<b>145</b>	Cleaning the main unit .....	194
<b>Thumbnail operation .....</b>	<b>146</b>	Cautions for storage .....	194
Thumbnail operation overview .....	146	<b>Chapter 11 Specification .....</b>	<b>195</b>
Thumbnail screen .....	146	<b>Dimensions .....</b>	<b>196</b>
Copying clip .....	149	<b>Specifications .....</b>	<b>197</b>
Deleting clips .....	150	General .....	197
Protecting clips .....	150	Camera .....	197
Restoring clips .....	151	Memory card recorder .....	198
Playing back clips .....	152	Digital video .....	199
<b>Useful playback function .....</b>	<b>154</b>	Digital audio .....	199
Resume play .....	154	Streaming .....	199
<b>Still image recording function .....</b>	<b>155</b>	Wi-Fi .....	199
<b>Chapter 7 Output and Screen Display .....</b>	<b>156</b>	Video output .....	199
<b>Output format .....</b>	<b>157</b>	Audio input .....	200
Format that can be output from the <SDI OUT> terminal		Audio output .....	200
[X2000] .....	157	Other input/output .....	200
Format that can be output from the <HDMI> terminal .....	158	Monitor .....	200
<b>Screen status display .....</b>	<b>159</b>	Handle unit ([X2000] supplied, [X1500] optional) .....	200
Screen display during shooting .....	159	AC adaptor .....	200
Screen display during playback .....	163	Battery pack (AG-VBR59) .....	200
Checking and displaying shooting status .....	164	<b>Index .....</b>	<b>201</b>
Mode check display .....	165	<b>Useful Information (Only For Latin American Countries) .....</b>	<b>203</b>
<b>Chapter 8 Connecting to External Devices .....</b>	<b>167</b>		
<b>Connecting with headphones and TV/monitor .....</b>	<b>168</b>		
Headphones .....	168		
Remote control .....	168		
TV/monitor .....	169		
<b>Connection function via the USB terminal .....</b>	<b>170</b>		
Connection with a computer in card reader mode .....	170		
Operating environment (mass storage) .....	171		
<b>Remote operation by iPhone/iPad or Android terminal .....</b>	<b>172</b>		
<b>Chapter 9 Network Connection .....</b>	<b>173</b>		
<b>Network connection .....</b>	<b>174</b>		
Available functions .....	174		
About the wireless LAN function on this unit .....	174		
<b>Network settings .....</b>	<b>175</b>		
Wireless LAN settings .....	175		
Confirming the network status .....	177		
<b>Connecting to the iPhone/iPad or Android terminal .....</b>	<b>178</b>		
Unit settings .....	178		
Preparing the HC ROP app .....	179		
Connecting to the HC ROP app .....	179		
Operation while the HC ROP app is connected .....	179		
<b>Streaming function .....</b>	<b>180</b>		
Unit settings .....	180		
Starting streaming with an operation from the application			
software .....	181		
Starting streaming with an operation on the unit .....	182		
Entering the setting using the setting tool .....	183		

# Chapter 1 **Overview**

---

Before using the unit, read this chapter.

## Before using the unit

### ■ Before using the unit, always check if the built-in battery is not consumed, and then set the date/time.

The date of the internal clock of the unit resets to January 1, 2020 if the built-in battery is exhausted. This may result in the meta data of the clip not being recorded correctly, and it may not display correctly in the thumbnail screen.

Connect the AC adaptor to the main unit or attach a battery when recharging the built-in battery.

The date/time set on the main unit is maintained for approximately 6 months when left in this state for approximately 24 hours.

(Recharged even when the power is on.)

For details about setting the time zone and date/time, refer to [TIME ZONE] (→ 17) and [CLOCK SETTING] (→ 17).

### ■ Do not use the unit in oily-smoky or dusty places.

Performance may be adversely affected if small particles or other foreign objects get inside the product.

Take extra care in environments where a special effect such as theatrical smoke is used.

### ■ When using this product during rain or snow or when at the beach, be careful that water does not get inside the camera.

Water causes damage to the camera and memory card. (Repair may be impossible)

### ■ Take care so sand and/or dust do not get inside the camera when using it at the beach, etc.

Sand and dust may damage the camera and memory card. (Be careful when inserting or removing the memory card)

### ■ AC adaptor and battery

- It may take more time to charge or may not be able to charge when the temperature of the battery is extremely high or extremely low.
- Noise may be generated in radio when the unit is used close to a radio (especially when receiving AM). Keep a distance of 1 m (approx. 3.3 feet) or more when using.
- Oscillating sound may generate inside the AC adaptor during the use, but this is not a malfunction.
- Always disconnect the power plug from the power outlet after the use. (Power of approximately 0.1 W is consumed by the AC power itself if kept connected)
- Do not get the terminal section of the AC adaptor, or the battery dirty. Install the device close to the power outlet so the disconnection device (power plug) can be easily reached.

### ■ Charging lamp during charging

When the charging lamp is flashing, the following should be considered.

#### Flashing with approx. 4 second period (on for approx. 2 seconds, off for approx. 2 seconds):

- When the battery is over discharged or the temperature of the battery is too high or low.  
It can be charged, but it may take a few hours to complete the charging normally.
- Once normal charging starts, the charging lamp lights up green. However, depending on the conditions of use, even when normal charging is taking place, the charging lamp may keep flashing in approx. 4 second intervals until charging is completed.

#### Flashing with approx. 0.5 second period (on for approx. 0.25 second, off for approx. 0.25 second):

- The battery is not charged. Remove the battery from the unit, and try charging again.
- Check that the terminals of the unit or battery are not dirty or covered with a foreign object, and connect the battery correctly once again.  
If a foreign object or dirt is present, turn off the unit before removing.
- The battery or environment is at an extremely high or low temperature. Wait until the temperature has returned to an appropriate level and try charging again. If you are still unable to charge, there may be a fault in the main unit, battery or AC adaptor.

#### Off:

- Charging has finished.
- If the status indicator stays off despite the charging being unfinished, there may be a fault in the unit, battery or AC adaptor.
- If the operating time is very short even after the battery has been recharged, the battery has worn out. Please purchase a new battery.

### ■ Memory cards

- The surface of this unit or the memory card may get slightly hot when used for a long period of time, but this is not a malfunction.
- The amount of memory included on the label of the memory card is the total amount of memory below.
  - Capacity to protect and manage copyright
  - Capacity usable as the normal memory on the unit or a PC.
- Do not give a strong impact to, bend, or drop the memory card.
- Memory card data may become destroyed or erased in the following cases.
  - Electrical noise or static electricity
  - Malfunction of the unit or the memory card
- Do not perform the following operations when accessing the memory card (the card 1 access lamp/card 2 access lamp is flashing in orange).
  - Removing the memory card
  - Disconnecting battery or the AC adaptor without turning off the main unit
  - Apply vibration of impact

### ■ Take care not to drop the main unit when carrying the camera.

- Strong impact will damage the main unit, and it may not operate properly.
  - Hold the handle\* or grip when carrying the camera, and handle it carefully.
- \* The handle can be used when the handle unit (X2000) supplied, (X1500) optional) is attached.

■ **Do not apply insecticide or volatile material to the camera.**

- The main unit may deform or the paint may peel off when insecticide or volatile material is applied.

■ **Do not allow the camera to remain in contact with a rubber or vinyl object for a long period of time.**

■ **Disconnect the battery or disconnect the AC cable from the power outlet after the use.**

■ **Battery characteristics**

The battery is a rechargeable lithium-ion battery. It produces electrical energy via an internal chemical reaction. This chemical reaction is effected by the ambient temperature and humidity. The usable time of the battery becomes shorter when the temperature gets higher or lower. When used in an environment with extremely low temperature, it can only be used for approximately 5 minutes.

When the battery is in an extremely hot environment, its protective function will operate and the unit cannot be used temporarily.

■ **After using the unit, be sure to remove the battery.**

Securely remove the battery from the camera.

(Minute current is consumed even if the camera is turned off when the battery is left attached)

The battery will become over discharge and may become unusable even if it is recharged when the battery is left attached for long period of time.

Do not remove the battery when the power is turned on.

Turn off the power and remove the battery after the operation lamp goes completely out.

■ **Take proper care of the battery terminal.**

Do not allow dust or foreign objects on the battery terminal.

Confirm that the battery and its terminal section is not deformed when the battery is dropped by mistake.

Do not mount a deformed battery to the camera. This may damage the camera.

■ **Cautions when throwing memory cards away or transferring them to others**

Formatting memory cards or deleting data using the functions of the unit or a computer will merely change the file management information: it will not completely erase the data on the cards.

It is recommended to completely erase the data in following method when discarding/conveying.

- Physically destroy the memory card itself
  - Completely erase the data in the memory card using a commercially available data erasing software for PC, etc.
- Users are responsible for managing the data stored in their memory card.

■ **LCD monitor and viewfinder**

- Condensation sometimes forms on the LCD panel of the LCD monitor in locations subject to extreme temperature differences. If this happens, wipe with a soft, dry cloth.
- Do not touch the LCD monitor with your finger nails, or rub or press with strong force.
- The LCD monitor will be slightly darker than normal immediately after the power is turned on when the camera is very cold. It will return to its regular brightness when the internal temperature increases.
- The LCD monitor and viewfinder are managed with high precision so that at least 99.99% of the dots are effective pixels and 0.01% or less are invalid pixels and always lit. This is not a malfunction and it has no effect whatsoever on the recorded images.
- It may become difficult to see or difficult to recognize the touch when a LCD protection sheet is affixed.

■ **About Condensation (When the lens, the viewfinder or LCD Monitor is fogged up)**

Condensation occurs when there is a change in temperature or humidity, such as when the unit is taken from outside or a cold room to a warm room. Please be careful, as it may cause the lens, the viewfinder or LCD monitor to become soiled, moldy, or damaged.

When taking the unit to a place which has a different temperature, if the unit is accustomed to the room temperature of the destination for about 1 hour, condensation can be prevented. (When the difference in temperature is severe, place the unit in a plastic bag or the like, remove air from the bag, and seal the bag.)

When condensation has occurred, remove the battery and/or the AC adaptor and leave the unit like that for about 1 hour. When the unit becomes accustomed to the surrounding temperature, fogginess will disappear naturally.

■ **Caution regarding laser beams**

The MOS sensor may be damaged if the MOS sensor is subjected to light from a laser beam.

Take sufficient care to prevent laser beams from striking the lens when shooting in an environment where laser devices are used.

■ **Treatment of clips**

Clips recorded with devices other than this unit are not supported by this unit.

■ **Regarding system frequencies**

You can change the system frequency (59.94 Hz/50.00 Hz) for this unit by using the menu. ([FREQUENCY]: → 89)

- When AVCHD clips are recorded, it is not possible to use the same memory card with different system frequencies. When the system frequency is changed, use a different memory card.

■ **Note the following points.**

- If you prepare to record important images, always shoot some advance test footage to verify that both pictures and sound are being recorded normally.
- Panasonic will not assume liability when video or audio recording fails due to a malfunction of the unit or the memory card during the use.
- Set the calendar (datetime of the internal clock) and the time zone, or check the setting before recording. This will have an effect on the management of the recorded contents.

■ **Exemption of liability**

Panasonic is not liable in any way regarding following.

- 1 **Incidental, special, or consequential damages caused directly or indirectly by the unit**
- 2 **Damages, breakage of the unit, etc., caused by misuse or carelessness of the customer**
- 3 **When disassembly, repair, or modification of the unit is performed by the customer**
- 4 **Inconveniences, damnification, or damages by not being able to record and/or display the video due to any reasons including failure or malfunction of the unit**
- 5 **Inconveniences, damnification, or damages resulting from malfunction of the system combining with any third party equipment**
- 6 **A liability claim or any claim for a privacy violation by an individual or a group that was the subject of the video that the customer has shot (including recording) that became public by any reason (including using with the network user authentication turned OFF)**
- 7 **The registered information is lost due to any reason (including initializing this unit because the authentication information such as user name or password is forgotten)**

■ **Cautions regarding network**

Since this unit is used connected to a network, following mischief may occur.

- 1 **Leaking or divulging of information through the unit**
- 2 **Fraudulent operation of the unit by a malicious third party**
- 3 **Obstruction and/or stopping of the unit by a malicious third party**

It is customer's responsibility to take sufficient network security measures including the following to prevent damage caused by such mischief. Please note that Panasonic is not liable in any way for damage caused by such mischief.

- Use the unit on a network where safety is secured by using a firewall, etc.
- When using the unit on a system where a PC is connected, make sure that checking and cleaning of infection by computer virus and malicious program is performed periodically.
- In order to prevent malicious attacks, use the authentication system and change the default setting values by using 8 characters or more including 3 or more character types for the authentication information (such as user name and password) so that a third party cannot guess your authentication information.
- Store the authentication information (user name, password, etc.) appropriately so it is not visible to the third party.
- Periodically change the authentication information (user name, password, etc.) and do not use the same authentication information as other accounts.
- To prevent the setting information in the unit to leak to the network, execute measure such as restricting the access with user authentication, etc.
- Do not install in a location where the unit, cable, etc., can be easily damaged.

■ **Security**

Take caution so the unit or memory card is not stolen, lost, or neglected. Note that Panasonic is not liable to leakage, falsification, or loss of information caused by them.

■ **When requesting repairs, or when transferring ownership/disposing of the product**

- After first taking note of personal information, make sure you delete information in this unit that includes personal information, including the wireless LAN connection settings, etc., that you have registered or set in this unit, using the following menu settings:
  - [NETWORK] menu → [UTILITY] → [NETWORK INITIALIZE]
  - [OTHERS] menu → [MENU INITIALIZE]
- Remove the Memory Card from this unit when requesting a repair.
- Settings may return to factory default when this unit is repaired.
- Please contact the dealer where you purchased this unit or Panasonic if above operations are not possible due to malfunction.
- (For the X2000 )  
When requesting a repair for the handle unit, request a repair for the video camera as well, as the cause of the problem may be in the video camera.

## Accessories/Optional accessories

### Accessories

Check the accessories before using this unit.

Product numbers correct as of January 2020. These may be subject to change.

#### Battery pack (→ 28) AG-VBR59



#### AC adaptor (→ 29) SAE0011A

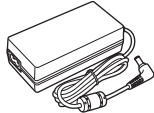

#### AC cable (→ 29) ● For AC adaptor K2CA2YY00259



#### Lens hood (→ 31) DVYE1189Z

- Pre-attached to the main unit.

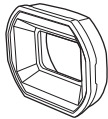

#### Eye cup (→ 32) DVZE1040Z



#### ■ For the X2000

The following accessories are also supplied.

#### Handle unit (→ 33) VW-HU1

- To purchase as a supplied accessory, use part number 1KC1VWHU1PPK when ordering.

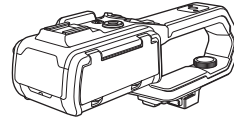

#### 1AC2HCX2500Z

##### Microphone holder (→ 33)

- The microphone holder mounting screws are supplied with the microphone holder.

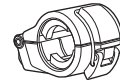

##### Microphone holder mounting screws (→ 33)

#### 1PP1HCX2500Z

- Length 12 mm (0.47") (x2)



(For U.S.A. only)

If accessories are lost, customers can visit us at

<http://shop.panasonic.com/support>







for further information about obtaining replacement parts.

#### NOTE

- Appropriately discard the AC cable cap (if attached) and packing materials after taking the product out.

## Optional accessories

Some optional accessories may not be available in some countries.

Accessory No.	Figure	Description
AG-MC200G*		Unidirectional microphone
VW-VMS10PP		Stereo microphone
AG-BRD50		Battery charger
VW-VBD58		Battery pack
AG-VBR59		Battery pack
VW-LED1PP		LED video light
VW-HU1		Handle unit

\* Handle unit (  X2000 supplied,  X1500 optional (VW-HU1)) required.

(For U.S.A. only)

To order optional accessories please visit <http://shop.panasonic.com>  
or your local Photo Specialty Dealer.

**NOTE:**

Accessories and/or model numbers may vary by country. Please consult your local dealer.  
Product numbers correct as of January 2020. These may be subject to change.



## When turning on the power for the first time

The time zone, date, and time are not set when the unit is shipped.

[TIME ZONE] is displayed in the LCD monitor when the power is turned on for the first time.

Follow the guidance and make the settings in the order of [TIME ZONE] and then [CLOCK SETTING].

- You can do these operations either with the multial or by touching the LCD monitor.

### [TIME ZONE]

Set the time difference from the Greenwich Mean Time.

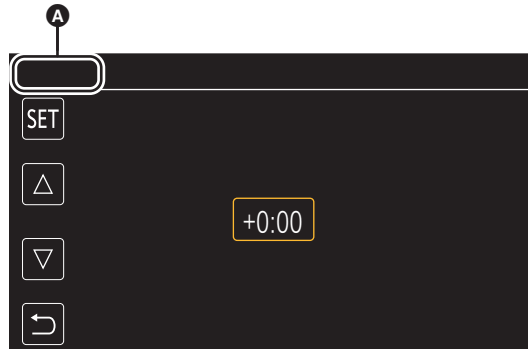

**A** [TIME ZONE]

**1** Set the time difference.

**2** Select [SET].

Once the setting for [TIME ZONE] is completed, the [CLOCK SETTING] screen is displayed.

#### NOTE

- The setting for the date/time of the main unit changes together with the time zone settings.
- This can also be set with the [OTHERS] menu → [CLOCK] → [TIME ZONE].

### [CLOCK SETTING]

Set the year, month, date, and time.

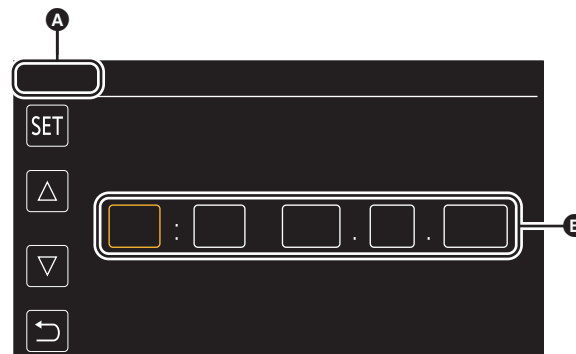

**A** [CLOCK SETTING]

**B** 0 : 0 JAN. 1. 2020

**1** Set the year, month, date, and time.

The year can be set between 2018 and 2037.

**2** Select [SET].

Once the setting is complete, the camera image screen is displayed.

#### NOTE

- This can also be set with the [OTHERS] menu → [CLOCK] → [CLOCK SETTING].

## What you can do with this unit

### Recording to the memory card

Recording in following types is possible.

- MOV recording (UHD and FHD recording)
- MP4 recording (UHD and FHD recording)
- AVCHD recording
- Simultaneous recording
- Relay recording
- Interval recording
- Background recording
- Pre-recording

### Linking to external devices

#### Connecting to TV/monitor

Connect to a TV/monitor and output images.

- When using **X2000**, use a BNC cable (<SDI OUT> terminal) to connect a TV/monitor.

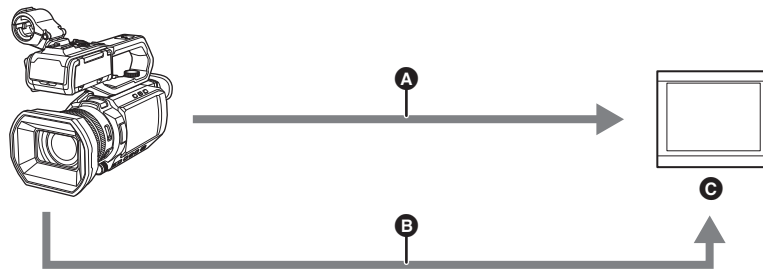

- A** HDMI cable
- B** (For the **X2000**)  
BNC cable (<SDI OUT> terminal)
- C** TV/Monitor

- Use a commercially-available High Speed HDMI cable. If possible, we recommend using a cable with a length of 3 m (approx. 9.8 feet) or less.
- (For the **X2000**)  
Use a commercially-available 5C-FB or equivalent double-shielded cable for the BNC cable.

**When using a DVI converter, etc., to connect an HDMI cable to this unit, make sure that you connect last to the <HDMI> terminal on this unit. Connecting first to the <HDMI> terminal on this unit may cause a malfunction.**

#### Card reader mode

Data (files) for performing nonlinear editing on a computer are transferred.

- The unit supports USB2.0.

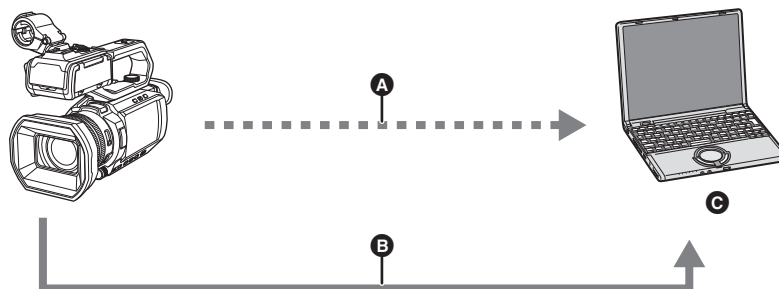

- A** Memory card\*1
- B** USB2.0 cable\*2
- C** Computer

\*1 Memory cards are optionally available. They are not supplied with the unit.

\*2 A USB2.0 cable is not supplied with the unit.

Use a commercially-available generic USB cable conforming to USB2.0. If possible, we recommend using a cable with a length of 1.5 m (approx. 4.9 feet) or less.

The unit does not offer a bus-powered function.

## Connecting to the network

This unit is equipped with wireless LAN. It can connect to wireless LAN devices via a network.

### Available functions

When the unit is connected to a network, the following functions are available.

#### ■ Connecting to HC ROP app

You can remotely control this unit with the HC ROP app by connecting this unit with an iPhone/iPad or Android terminal via wireless LAN.

- Checking camera status
- Camera remote control (focus, zoom, image quality settings, recording control such as start/end recording, and time code/user bits settings)
- Menu Operations
- Starting and stopping streaming (when the function is assigned to the USER button)

The unit supports the multi camera function, with which a camera selected from up to 8 cameras is remotely controlled from a single device.

For details about operation of the HC ROP app, refer to the online help for the app.

#### ■ Streaming function

You can perform streaming of audio and video currently shot with the unit over a network (wireless LAN).

## Chapter 2 **Description of Parts**

---

This chapter describes the names, functions, and operations of parts on the unit.

## Main unit

The illustrations in this document show the handle unit ( **X2000** supplied, **X1500** optional) removed.

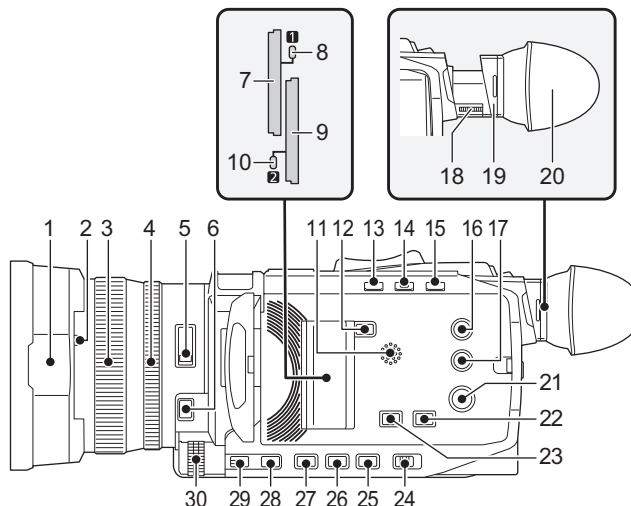

- 1 Lens hood (→ 31)**
- 2 Lens cover switching lever (→ 32)**  
Opens/closes the lens cover.
- 3 Focus ring (→ 111)**  
When the <FOCUS A/M/∞> button is pressed to set to manual focus mode ([MF]) you can focus manually.
- 4 Rear ring (→ 108, 110, 118)**  
You can manually perform zoom operations, adjust the iris (the lens stop), and adjust the AE level (exposure compensation).
  - You can switch the function to be adjusted by setting with the menu, pressing the USER button assigned to [REAR RING], or touching the USER button icon.
- 5 <ND FILTER> switch (→ 111)**  
Selects the ND filter to suit the illumination of the subject.  
<1/64>: Reduces the amount of light entering the MOS sensor to 1/64.  
<1/16>: Reduces the amount of light entering the MOS sensor to 1/16.  
<1/4>: Reduces the amount of light entering the MOS sensor to 1/4.  
<CLR>: Does not use the ND filter.
- 6 <FOCUS A/M/∞> button (→ 111)**  
Select the focus function.  
[AF] and [MF] switch each time you press the button. The focal point goes to infinity after you press and hold the button, and then the manual focus mode is engaged.  
[AF]: Changes to the auto focus mode. The auto focus mode adjusts the focus automatically.  
[MF]: Changes to the manual focus mode. Control the focus ring manually to adjust the focus.
- 7 Card slot 1 (→ 41)**  
A slot for the memory card.
- 8 Card 1 access lamp (→ 41)**  
Indicates the access status for recording and playback of the memory card inserted in card slot 1.
- 9 Card slot 2 (→ 41)**  
A slot for the memory card.
- 10 Card 2 access lamp (→ 41)**  
Indicates the access status for recording and playback of the memory card inserted in card slot 2.
- 11 Built-in speaker**  
Outputs audio during playback.  
Audio is not output from the built-in speaker when headphones are connected to the headphone terminal.
- 12 <SLOT SEL> button**  
Selects the card slot to record to or play back from.
- 13 <USER1> button (→ 50, 141)**  
Used as a USER button (USER1).
  - [LEVEL GAUGE] is allocated at the time of purchase.  
Switches display/hide of level gauge.
- 14 <USER2> button (→ 50, 109)**  
Used as a USER button (USER2).
  - [BACKLIGHT] is allocated at the time of purchase.  
Switches enable/disable of the auto iris control function for backlight compensation.
- 15 <O.I.S.>/<USER3> button (→ 50, 138)**  
Switches enable/disable of the optical image stabilizer function. This is also used as the USER button (USER3).
- 16 <THUMBNAIL> button (→ 146)**  
Press the button to switch between the camera image screen and the thumbnail screen.
- 17 <DISP/MODE CHK> button (→ 165)**  
Switches display/hide of information other than the time counter, time stamp, zebra pattern, and marker.  
Press and hold the button to display information about the settings of the various shooting functions and information such as a list of the functions assigned to the USER button. Each press of the button switches the information page in order.
- 18 Diopter adjustment dial (→ 54)**  
Adjusts the diopter scale so that the viewfinder screen can be viewed clearly.
- 19 Eyepiece**  
Do not leave the eyepiece pointed toward the sun. Doing so might damage the devices inside.
- 20 Eye cup (→ 32)**
- 21 Power button (→ 37)**  
Press the button to switch the power on/off.
- 22 <WHITE BAL> button (→ 114)**  
Selects the method for adjustment of the white balance.  
Each time you press the button, the white balance switches in the order "Preset", [Ach], [Bch].  
"Preset": Adjusts the white balance to the preset value. Each time you either press the USER button assigned to [AWB] or touch the USER button icon, the setting changes in the order [P 3200K], [P 5600K], "VAR" (screen display example: [V 3200K]).  
[Ach]/[Bch]: Selects when using the stored value for the adjustment of the white balance.
- 23 <AE LEVEL>/<USER4> button (→ 50, 110)**  
Switches enable/disable of the AE level function.  
Set the target value of the AE level in the [SCENE FILE] menu → [AE LEVEL EFFECT].  
This is also used as the USER button (USER4).
- 24 <AUTO/MANU> switch (→ 104)**  
Selects the method to adjust the focus, gain, iris, white balance, and shutter speed at shooting.  
<AUTO>: Adjusts automatically. (Auto mode)  
<MANU>: Adjusts manually. (Manual mode)

**25 <SHUTTER> button (→ 112)**

Switches the shutter mode.

**26 <GAIN> button (→ 109)**

Selects the method for adjusting screen brightness.

**27 <IRIS> button (→ 108)**

Selects the method for adjustment of the lens stop.

**28 <MENU> button (→ 60)**

Displays the menu. Pressing the <MENU> button while the menu is displayed closes the menu.

Press the button while the thumbnail screen is displayed to display the operation screen of the thumbnail menu, and clips can be deleted.

**29 <EXIT> button**

Returns to one level higher when the menu is displayed. Pressing the <EXIT> button without confirming the setting value will not reflect the change in the setting.

**30 Multidial (→ 143)**

Moves, selects, and sets the menu while the menu is displayed. Use the multidial to also operate thumbnails, select the multi manual function and select/set the various operation icons.

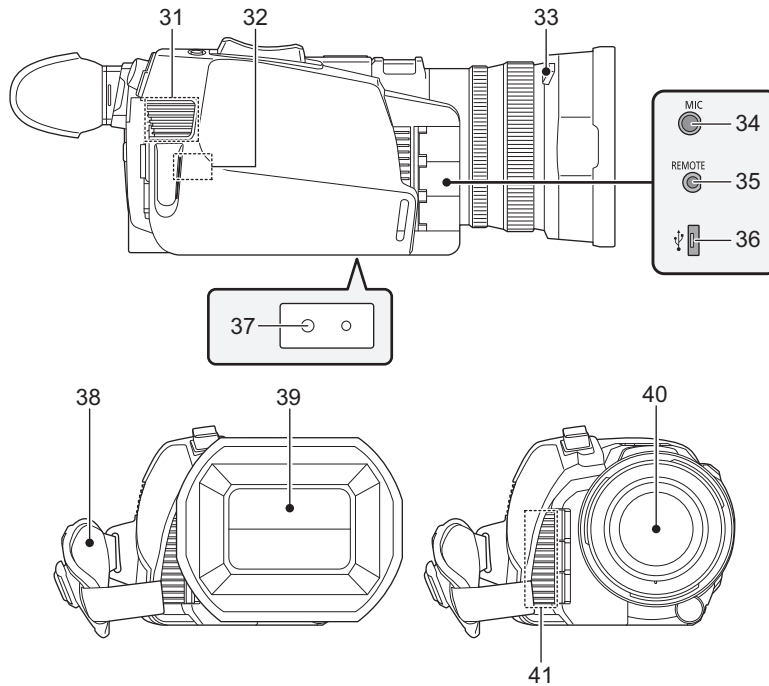

**31 Fan inlet**

Fan inlet for cooling fan. Do not block this while the unit is being used.

**32 Wireless LAN Transmitter**

**33 Lens hood release button (→ 31)**

**34 <MIC> terminal (→ 36, 125)**

Connect an external microphone (stereo mini jack).

**35 <REMOTE> terminal**

Connects the remote control unit (commercially-available) to control some functions remotely.

**36 USB terminal (→ 170)**

Connect to a computer with the USB2.0 cable to transfer data.

**37 Tripod mounting holes (→ 36)**

Attach the tripod. (bottom)

- Mounting hole size
  - 1/4-20 UNC (screw length 5.5 mm (0.22") or shorter)
- Attaching a tripod with a screw length of 5.5 mm (0.22") or more may damage the unit.

**38 Grip belt (→ 31)**

**39 Lens cover (→ 32)**

**40 Lens**

**41 Fan outlet**

Fan outlet for cooling fan. Do not block this while the unit is being used.

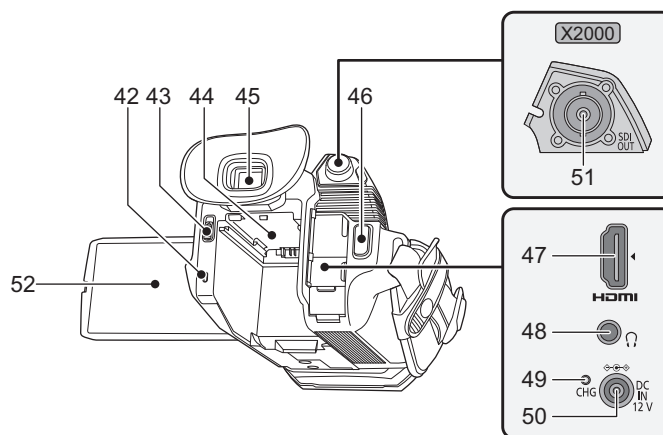

- 42 Status indicator (→ 37)**  
Illuminates when power is on.
- 43 Battery release lever (→ 28)**  
Used when removing the battery from the main unit.
- 44 Battery mounting section (→ 28)**  
Attaches a battery.
- 45 Viewfinder (→ 54)**
- 46 REC button (on the grip) (→ 104)**  
Starts or stops the recording.  
It is possible to directly record from the thumbnail mode.
- 47 <HDMI> terminal (→ 169)**  
A terminal to output video signal by connecting a monitor, etc.
- 48 Headphones terminal**  
Connects audio monitoring headphones.
- 49 Charging lamp (→ 29)**  
Illuminates when the battery is charging.
- 50 <DC IN 12V> terminal (→ 29)**  
Connects the supplied AC adaptor and supplies an external power.
- 51 (For the X2000 )**  
**<SDI OUT> terminal (→ 169)**  
A terminal to output SDI signal by connecting a monitor, etc.
- 52 LCD monitor (→ 53)**

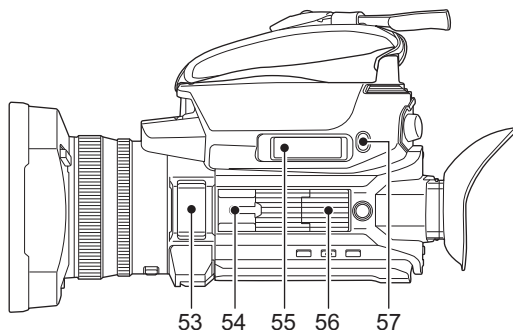

- 53 Built-in microphone (→ 125)**  
This is the built-in stereo microphone <L>/<R>.
- 54 Accessory shoe (on the main unit)**  
Attach a video light, etc.
- 55 Zoom lever (on the grip) (→ 118, 153)**  
Adjusts the zoom of an image.  
<T>: Zooms in the image.  
<W>: Zooms out the image.  
• Adjust the volume when playing back clips.
- 56 Handle unit mounting section (→ 33)**
- 57 <USER5> button (→ 50, 105)**  
Used as a USER button (USER5).  
• [REC CHECK] is set at the time of purchase.  
Automatically plays back the last approximately 3 seconds of the previously shot clip.

## Handle unit ([X2000] supplied, [X1500] optional: VW-HU1)

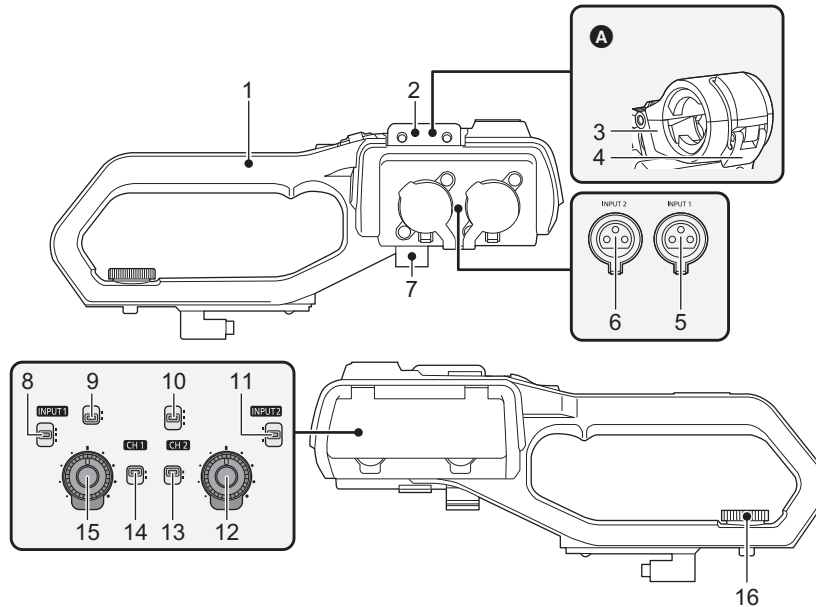

**A** With a microphone holder attached

**1 Handle**

**2 Microphone holder mounting section (→ 33)**

Attaches the supplied microphone holder with the microphone holder mounting screws.

**3 Microphone holder (→ 33, 35)**

Secures the external microphone in place.

**4 Buckle (→ 33, 35)**

Used to open and close the microphone holder.

**5 <INPUT 1> terminal (XLR, 3-pin) (→ 35, 125)**

Connects an audio equipment or an external microphone.

**6 <INPUT 2> terminal (XLR, 3-pin) (→ 35, 125)**

Connects an audio equipment or an external microphone.

**7 Microphone cable clamp (→ 35)**

Fixes the external microphone cable.

**8 <INPUT1> switch (→ 126)**

Switches audio input signals connected to the <INPUT 1> terminal.  
 <LINE>: Select when audio equipment is connected by the line input.  
 <MIC>: Select when the external microphone is connected.  
 <+48V>: Select when the external microphone is connected and the microphone needs a power supply.

**9 CH1 SELECT switch (→ 125)**

Selects the audio to be recorded on audio channel 1.  
 <INT/MIC (L)>: Records left audio from the built-in microphone or <MIC> terminal.  
 <INPUT1>: Records input signals from the <INPUT 1> terminal.

**10 CH2 SELECT switch (→ 125)**

Selects the audio to be recorded on audio channel 2.  
 <INT/MIC (R)>: Records right audio from the built-in microphone or <MIC> terminal.  
 <INPUT1>: Records input signals from the <INPUT 1> terminal.  
 <INPUT2>: Records input signals from the <INPUT 2> terminal.

**11 <INPUT2> switch (→ 126)**

Switches audio input signals connected to the <INPUT 2> terminal.  
 <LINE>: Select when audio equipment is connected by the line input.  
 <MIC>: Select when the external microphone is connected.  
 <+48V>: Select when the external microphone is connected and the microphone needs a power supply.

**12 <AUDIO LEVEL CH2> dial (→ 126)**

Adjust the recording level of audio channel 2.

**13 <CH2> switch (→ 126)**

Selects how the recording level for audio channel 2 is adjusted.  
 <AUTO>: Adjusted automatically.  
 <MANU>: Adjusted manually with the <AUDIO LEVEL CH2> dial.

**14 <CH1> switch (→ 126)**

Selects how the recording level for audio channel 1 is adjusted.  
 <AUTO>: Adjusted automatically.  
 <MANU>: Adjusted manually with the <AUDIO LEVEL CH1> dial.

**15 <AUDIO LEVEL CH1> dial (→ 126)**

Adjust the recording level of audio channel 1.

**16 Handle unit mounting screw (→ 33)**

Secures the handle unit to the main unit.



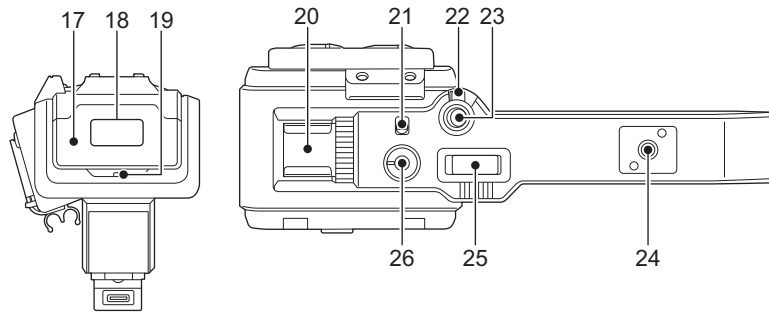

**17 Light cover**

- Keep the Light cover out of reach of children to prevent swallowing.

**18 Built-in LED light (→ 120)**

**19 Tally lamp (→ 55)**

Illuminates when the recording is started. Flashes when the battery level becomes low.

Whether or not to illuminate the lamp can be set in the menu.

**20 Accessory shoe (on the handle)**

Attach a video light, etc.

**21 <LIGHT> switch (→ 120)**

Switches the built-in LED light on/off.

**22 Hold lever**

Disables the REC button (on the handle) when switched to <HOLD>.

**23 REC button (on the handle) (→ 104)**

Starts or stops the recording.

**24 Accessory mounting hole**

Accessories can be attached.

- Mounting hole size
  - 1/4-20 UNC (screw length 5.5 mm (0.22") or shorter)

**25 Zoom lever (on the handle) (→ 118)**

Adjust the zoom of an image.

<T>: Zooms in the image.

<W>: Zooms out the image.

- The zoom speed is controlled with this lever in a way different from the way it is controlled with the zoom lever (on the grip).

**26 Light dimmer dial (→ 120)**

Adjusts the brightness of the built-in LED light.

Turn to <+> to brighten, turn to <-> to dim.

## Basic operation

### Multidial operation

Operate the multidial on the main unit by turning it in vertical direction or pushing it.

- Turning the multidial in vertical direction will move the cursor.
- Pressing the multidial will select or confirm the item with cursor.
- Values of the menu or the pages of the thumbnail screen can be changed continuously by pressing and turning the multidial vertically to fix the setting.

#### NOTE

- For details about operating the menu, refer to “When operating with the multidial”. (→ 62)

### Touch operation of the LCD monitor

The LCD monitor can be operated by directly touching with a finger.

Do not touch the LCD monitor with a pointed hard object such as a ball point pen.

#### ■ Touching

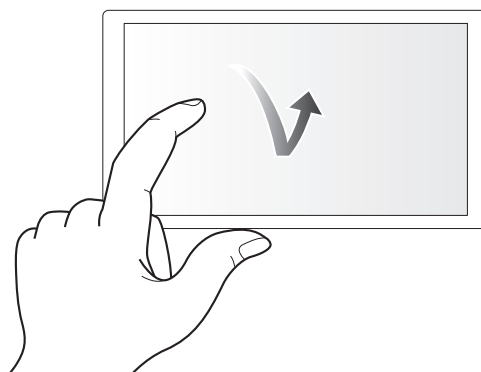

An operation to press and release the LCD monitor. An item or icon can be selected, or an item can be executed.

- To select an icon, touch the center of the icon.
- It will not operate while touching a different location of the LCD monitor.

#### ■ Sliding

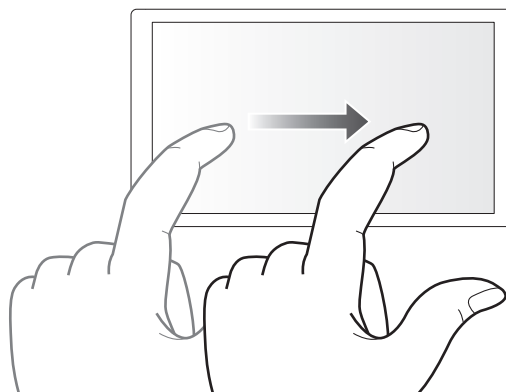

An operation to move a finger while touching the LCD monitor. Playback operation such as the skip playback or direct playback, etc. can be performed.

#### ■ Touching and holding

An operation to keep on pressing, then releasing the LCD monitor. Values of the menu or the pages of the thumbnail screen can be changed continuously.

#### NOTE

- For details about operating the menu, refer to “When operating by touching the LCD monitor”. (→ 63)

## Chapter 3 **Preparation**

---

Before you use the unit, attach the battery following the procedures in this chapter. The attaching of accessories is also described in this chapter.

## Power supply

A battery or the supplied AC adaptor can be used as the power supply for the unit.

- The unit is compatible to following batteries. (As of January 2020)
  - AG-VBR59 (supplied/optional, supports quick charging)
  - VW-VBD58 (optional)
- AG-VBR59 supports quick charging. Use a battery charger (AG-BRD50: optional) to perform quick charging.

### Attaching and removing the battery

- Press the power button to turn off the unit. (→ 37)

#### Attaching the battery

- 1 Push the battery against the battery mounting section on the main unit and slide forward to attach.**

Press in the battery until it clicks and gets locked.

- A** Battery mounting section

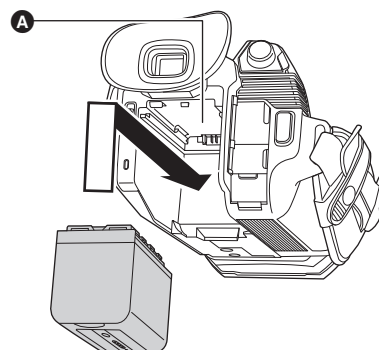

#### Removing the battery

Be sure to hold down the power button until the status indicator goes off. Then remove the battery while supporting the unit to prevent it from dropping.

- B** Status indicator

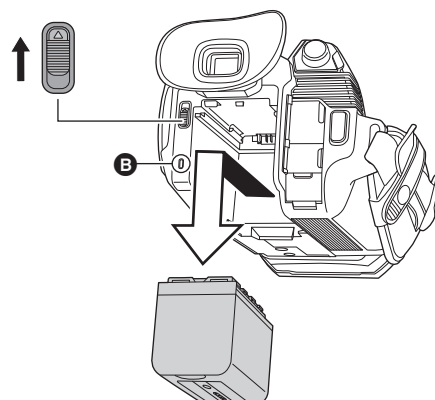

Move the battery release lever in the direction indicated by the arrow and remove the battery when unlocked.

## Charging the battery

The battery is not charged at the time of purchase. Use only after charging sufficiently.

It is recommended that you have one extra battery.

- It is recommended to perform charging of the battery in a location with ambient temperature of 10 °C to 30 °C (50 °F to 86 °F) (same for the battery temperature).
- Use the supplied AC adaptor. Do not use the AC adaptor of another device.
- The supplied AC cable is dedicated for this unit. Do not use with any other device. Also, do not use AC cable from other device on this unit.
- The battery is not charged when the power is on.

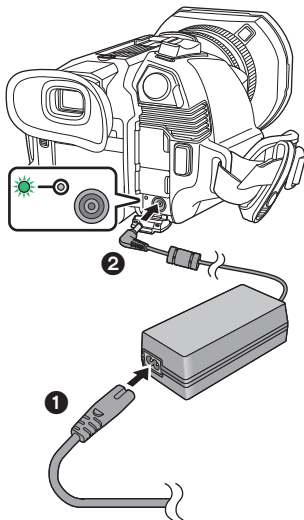

### 1 Connect the AC cable to the AC adaptor and the AC outlet.

- Insert the plugs as far as they will go.

### 2 Connect the AC adaptor to the <DC IN 12V> terminal.

- As the charging lamp lights up green, charging starts. It will turn off when the charging is completed.
- If the charging lamp flashes, refer to page 12.
- The DC plug of the AC adaptor, depending on its angle, may block your view of the charging lamp. To check the charging lamp status, adjust the angle of the DC plug.

### ■ Connecting to the AC outlet

It is possible to use this unit with power supplied from the AC outlet by turning on the unit with the AC adaptor connected.

Even when you use the AC adaptor for recording images, keep the battery connected.

This allows you to continue the recording even if a power failure occurs or the AC adaptor is unplugged from the AC outlet by accident.

- The AC adaptor is in the standby condition when the mains plug is connected. The primary circuit is always "live" as long as the AC adaptor is connected to an electrical outlet.

### NOTE

- Do not use any other AC adaptors except the supplied one.
- We recommend using Panasonic batteries (→ 28).
- If you use other batteries, we cannot guarantee the quality of this product.
- Do not heat or expose to flame.
- Do not leave the battery(ies) in a car exposed to direct sunlight for a long period of time with doors and windows closed.
- Do not expose to low air pressure at high altitudes.
- Do not expose to extremely low air pressure, as this may result in explosions or leakage of flammable liquids and gases.

**Standard charging time and recordable time**

Battery parts number	Voltage/capacity (minimum)	Charging time for main unit	[FREQUENCY]	Continuous recordable time	
				[X1500]	[X2000]
AG-VBR59 (supplied/optional)	7.28 V/5900 mAh	Approx. 5 h 30 min	[59.94Hz]	Approx. 5 h 20 min	Approx. 4 h 35 min
			[50.00Hz]	Approx. 5 h 40 min	Approx. 4 h 50 min
VW-VBD58 (optional)	7.2 V/5800 mAh	Approx. 5 h 15 min	[59.94Hz]	Approx. 5 h 15 min	Approx. 4 h 30 min
			[50.00Hz]	Approx. 5 h 35 min	Approx. 4 h 45 min

- “h” is an abbreviation for hour and “min” for minute.
- The charging time is the time when the operating ambient temperature is 25 °C (77 °F) and operating relative humidity is 60%. At other temperature and humidity the charging time may take longer.
- Continuous recordable time is the time when the unit is used fulfilling all of the following conditions. If you use the unit in other conditions, continuous recordable time will shorten.
  - When set to the factory default menu settings ([FILE FORMAT] is [MOV] and [REC FORMAT] is [2160-59.94p/HEVC LongGOP 200M]/[2160-50.00p/HEVC LongGOP 200M])
  - When the LCD monitor is used and cable is not connected to the external input/output terminal
- **The charging time is the time to charge when the charging capacity of the battery is used up. The charging time or the continuous recordable time differs depending on the use condition such as high or low temperature.**

**■ Batteries that support quick charging**

For quick charging of a battery (AG-VBR59: supplied/optional), use a battery charger (AG-BRD50: optional).

**NOTE**

- Battery is warm after using or after charging, but this is not a malfunction.

**Checking the remaining battery level**

The remaining battery level can be checked with the power status display on the LCD monitor or the indicator on the supplied battery.

**Checking the remaining battery level with the LCD monitor**

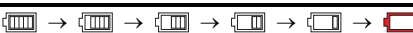
The battery status display will change as  while the remaining battery level gets lower. It will flash in red when the remaining battery level is zero.

**NOTE**

- The power status display may not be displayed depending on the setting in the menu.
- Repair or copy of the clip, or update of the firmware is not possible when it is flashing in red.

**Checking the remaining battery level with the battery**

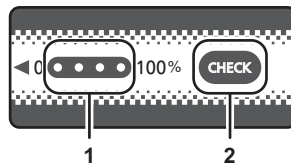

- The remaining battery level can be checked with the indicator display by pressing the <CHECK> button on the battery when it is not charging.
  - The remaining battery level is a rough indication.
  - The indicator will not illuminate even if the <CHECK> button is pressed when the remaining battery level is zero. Charge the battery.
- The progress of the charging is notified by the flashing position of the indicator while the battery is charging. Once the charging is completed, the indicator turns off.











1 Indicator

2 <CHECK> button

**■ Display of the indicator**

- The color and illuminate/flashing status of the indicator indicated by the icon in the table are as follows.
  -  : Flashing in green
  -  : Illuminated in green
  -  : Off

Indicator display		Remaining battery level/charging progress
When checking the remaining battery level	Charging	
		0% to 25%
		25% to 50%
		50% to 75%
		75% to 100%

- Display of the indicator is a rough indication. If the battery is attached to the unit or the battery charger (optional), check the remaining level on the device the battery is attached to. The remaining level may differ from the one displayed with the indicator on the battery.

## Attaching accessories

### Adjusting the grip belt

- Adjust the grip belt so that it fits the size of your hand.
- If the buckle is difficult to tighten, move the pad backward and tighten the buckle again.

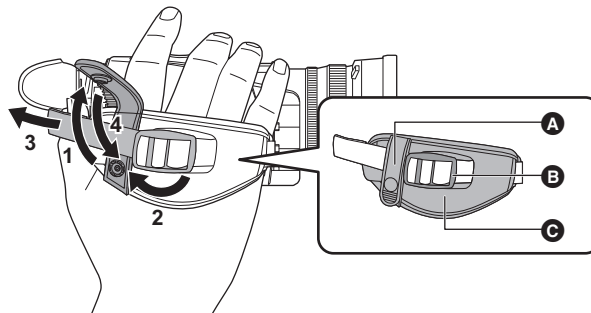

- Ⓐ Button
- Ⓑ Buckle
- Ⓒ Pad

- 1 Undo the button of the grip belt.**
- 2 Open the buckle section.**
- 3 Pull the end of the belt.**
- 4 Do up the button of the grip belt.**

### Attaching the lens hood

#### Removing

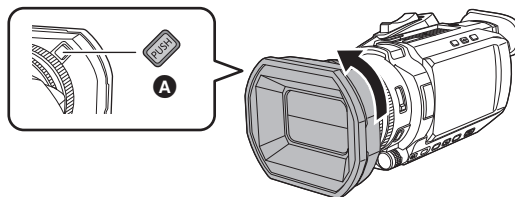

- Ⓐ Lens hood release button

- 1 While pressing the lens hood release button, turn the lens hood in the direction of the arrow to remove it.**

#### Attaching

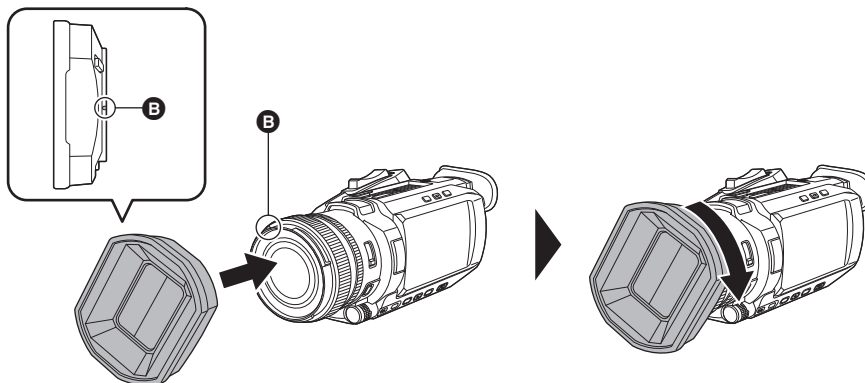

- Ⓑ Mounting mark

- 1 Insert the lens hood into the unit.**
  - Align the mounting marks on the lens hood and unit.
- 2 Turn the lens hood clockwise.**
  - Turn until the lens clicks and locks into place.

### Opening and closing the lens cover

Use the lens cover switching lever to open and close the lens cover.

Open the lens cover when shooting.

When not using the unit, close the lens cover in order to protect the lens.

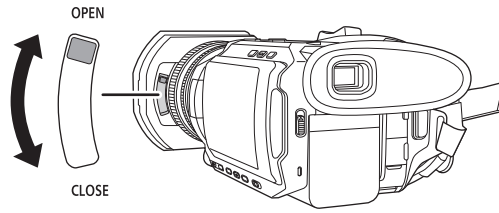

#### NOTE

- Do not press the lens cover with force. Doing so may damage the lens and lens cover.
- The lens cover may not open and close or the lens hood may not attach depending on the various filters and MC protectors mounted to the front lens of the unit.

### Attaching the eye cup

**1** Attach the eye cup by aligning the groove on the mounting part of the eye cup with the inner ridge of the eye cup.

The illustration below is an example of attaching the eye cup to use it with your right eye.

If you rotate the eye cup to the left by 180° before attaching it, you can use it with your left eye.

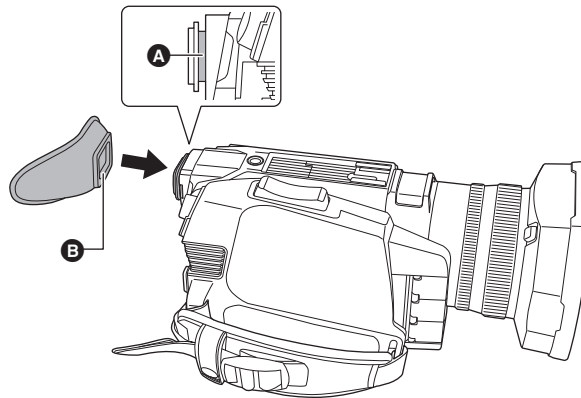

- A** Groove
- B** Ridge



## Attaching the handle unit ([X2000] supplied, [X1500] optional)

● Press the power button to turn off the unit. (→ 37)

### 1 Open the microphone holder.

Open buckle ①, and detach fitting ② from hook ③.

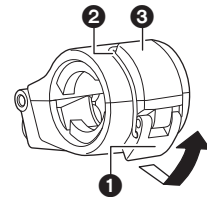

### 2 Attach the microphone holder to the microphone holder mounting section on the handle unit.

- Attach using a commercially-available screwdriver.
- There will be some rubbing noises with the rubber when screwing in the microphone holder mounting screws, but please ensure they are done up tightly.

- ① Microphone holder
- ② Microphone holder mounting screws

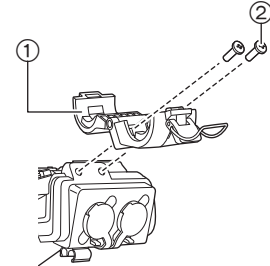

### 3 Push the handle unit into the handle unit mounting section on the camera.

Match the positions of mounting mark **A** on the handle unit and mounting mark **B** on the camera when pushing in.

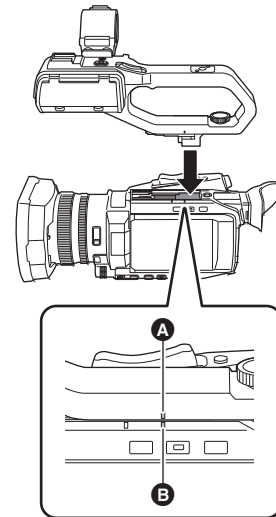

### 4 Slide the handle unit in the direction indicated by the arrow.

Slide up to mounting mark **C**.

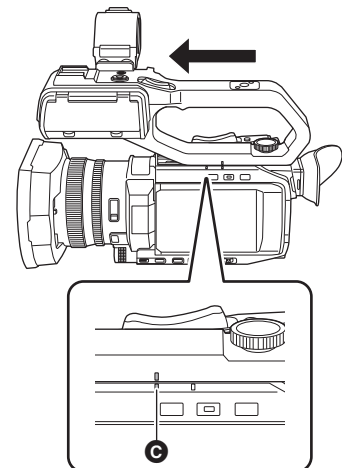

- 5** While pressing the handle unit mounting screw down, turn it in the direction indicated by arrow ② until it stops.

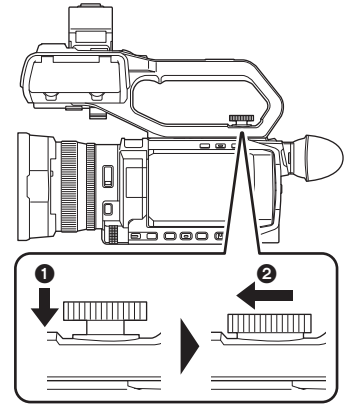

■ **How to remove**

Remove by doing the steps for attaching in reverse.

 **NOTE**

- Keep the microphone holder mounting screws out of reach of children to prevent swallowing.

## Attaching the external microphone

### ■ Attaching an external microphone to the <INPUT 1>/<INPUT 2> terminals

When the handle unit ( **X2000** supplied, **X1500** optional) is attached to the unit, you can attach an external microphone such as a unidirectional microphone AG-MC200G (optional) that is compatible with XLR terminals to the handle.

#### 1 Open the microphone holder.

#### 2 Attach the external microphone to the microphone holder, then close the buckle to secure the external microphone.

Attach the fitting to the hook and close the buckle in the direction indicated by the arrow.

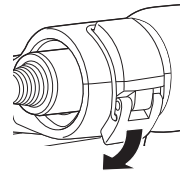

#### 3 Connect the microphone cable to the <INPUT 1> terminal **A**.

#### 4 Attach the microphone cable to the microphone cable clamp **B**.

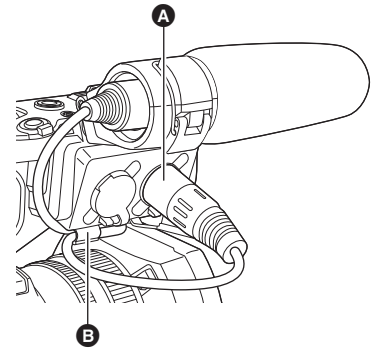

#### 5 Switch the <INPUT1> switch to match the microphone to be connected.

#### NOTE

- When removing the microphone cable from the <INPUT 1> terminal, remove by lifting levers **C**.

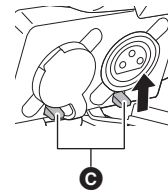

■ **Attaching an external microphone to the <MIC> terminal**

You can attach an external microphone, such as a Stereo Microphone VW-VMS10PP (optional), etc., that is compatible with the stereo mini jack.

**1 Attach the external microphone to the accessory shoe **A**.**

- For details about how to attach the external microphone, refer to the operating instructions for the external microphone.

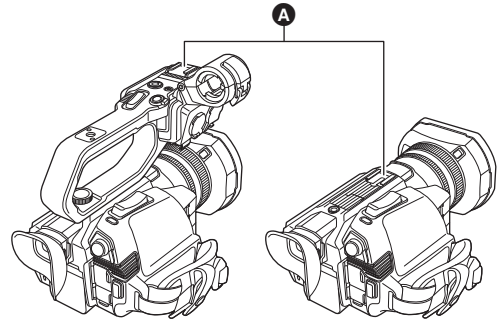

**2 Connect the microphone cable to the <MIC> terminal.**

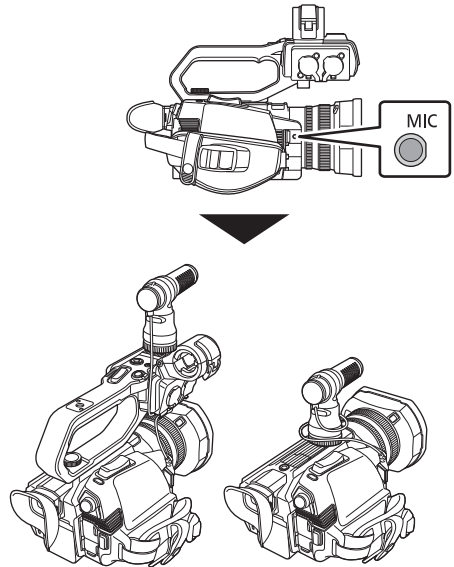

**Attaching a tripod**

The tripod mounting holes accept 1/4-20 UNC screws.

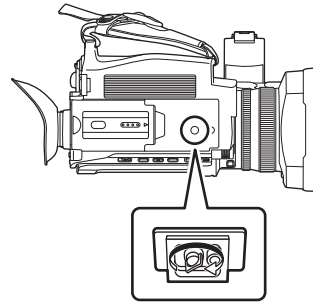

**NOTE**

- Use a tripod in safe locations.
- The depth of the tripod mounting holes is 5.5 mm (0.22"). Do not over-tighten the tripod screw when attaching the unit to a tripod.
- Attaching a tripod with a screw length of 5.5 mm (0.22") or more may damage the unit.

## Turning on/off the power

### Turning the unit on and off with the power button

- 1 Open the LCD monitor and press the power button to turn on the unit.

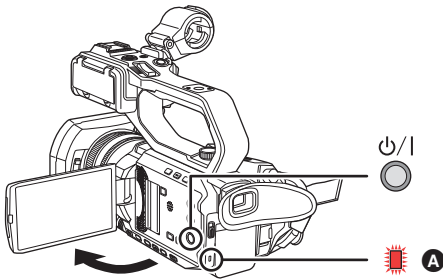

- A** The status indicator lights on.

#### ■ To turn off the unit

Hold down the power button until the status indicator goes off.

#### NOTE

- The [TIME ZONE] screen is displayed when the power is turned on for the first time. (→ 17)  
Set the time zone, date, and time.
- The built-in battery (rechargeable battery) will discharge. The setting for date/time may be initialized when the unit is not turned on for approximately 6 months.  
Set the date/time again after charging the built-in battery. (→ 38)

### Turning the unit on and off with the LCD monitor/viewfinder

Opening the LCD monitor or extending the viewfinder turns on the unit. Closing the LCD monitor/viewfinder turns off the unit.

During normal use, you may find it convenient to turn the unit on/off using the LCD monitor or viewfinder.

- The unit will not turn off unless the LCD monitor is closed and the viewfinder is retracted.
- The unit will not turn off during recording or while connected to a network even if the LCD monitor is closed and the viewfinder is retracted.
- In the following cases, opening the LCD monitor or extending the viewfinder does not turn on the unit. Press the power button to turn on the unit.
  - When the unit is originally purchased
  - When you have turned off the unit using the power button

## Charging the built-in battery

The date/time set in the unit is maintained by the built-in battery.

If this unit is left without turning the power on, and then when you turn the power on and [BACKUP BATT EMPTY] is displayed on the viewfinder and LCD monitor for approximately 5 seconds, the built-in battery is exhausted.

The date of the internal clock of the unit resets to January 1, 2020 if the built-in battery is exhausted.

Charge the built-in battery with the following procedure.

- 1 Press the power button to turn off the unit.

- 2 Connect a fully charged battery or the AC adaptor to the unit.

For details about the connection of the battery or AC adaptor, refer to “Power supply”. (→ 28)

- 3 Leave the unit for approximately 24 hours.

The built-in battery will be charged.

The built-in battery recharges even when the power is on.

Check the date/time setting and the time code after charging. If [INTERNAL CLOCK HAS RESET] [<PLEASE SET TO CORRECT TIME>] is displayed on the STATUS screen of the mode check, set the date/time of the internal clock. (→ 38)

- 4 Press the power button to turn on the power, and confirm that [BACKUP BATT EMPTY] is not displayed on the LCD monitor.

If [BACKUP BATT EMPTY] is still displayed after charging, the built-in battery needs to be replaced. Consult your dealer.

## Setting the date/time of the internal clock

The date/time/time zone are recorded as meta data in the clip while shooting.

This will affect the management of recorded clips, so always check and set the date/time and time zone before using the unit for the first time.

Do not change the setting of the date/time and time zone while shooting.

### 1 Press the <MENU> button.

The menu is displayed.

### 2 Select the [OTHERS] menu → [CLOCK] → [TIME ZONE], and set the time difference from Greenwich Mean Time.

### 3 Select the [OTHERS] menu → [CLOCK] → [CLOCK SETTING], and set the year, month, date, and time.

#### ■ Time zone table

Time difference	Region	Time difference	Region
+0:00	Greenwich	+0:30	
-0:30		+1:00	Central Europe
-1:00	Azores	+1:30	
-1:30		+2:00	Eastern Europe
-2:00	Mid-Atlantic	+2:30	
-2:30		+3:00	Moscow
-3:00	Buenos Aires	+3:30	Tehran
-3:30	Newfoundland	+4:00	Abu Dhabi
-4:00	Halifax	+4:30	Kabul
-4:30	Caracas	+5:00	Islamabad
-5:00	New York	+5:30	Mumbai
-5:30		+6:00	Dakar
-6:00	Chicago	+6:30	Yangon
-6:30		+7:00	Bangkok
-7:00	Denver	+7:30	
-7:30		+8:00	Beijing
-8:00	Los Angeles	+8:30	
-8:30		+9:00	Tokyo
-9:00	Alaska	+9:30	Darwin
-9:30	Marquesas Islands	+10:00	Guam
-10:00	Hawaii	+10:30	Lord Howe Island
-10:30		+11:00	Solomon Islands
-11:00	Midway Islands	+11:30	
-11:30		+12:00	New Zealand
-12:00	Kwajalein Atoll	+12:45	Chatham Islands
		+13:00	Phoenix Islands

#### NOTE

- Accuracy of the clock is approximately  $\pm 30$  seconds per month. Check and reset the time when accurate time is required.
- Due to the format specifications, with AVCHD format, the following time difference conversions are made for recording with the clip.

Time difference set in [TIME ZONE]	Time difference recorded with AVCHD clips
+12:45	+12:30

## Preparing the memory card

### Memory cards supported by the unit (As of January 2020)

Type of the memory card	Recording capacity
SDHC memory card	4 GB to 32 GB
SDXC memory card	48 GB to 128 GB

- Operation is not guaranteed for any memory cards other than the above.
- Panasonic memory cards are recommended.
- The following memory cards cannot be used because they do not comply with the SD standards.
  - A memory card with 4 GB or more without the SDHC logo
  - A memory card with 48 GB or more without the SDXC logo
- This unit supports the following memory cards:
  - SDHC/SDXC memory cards that conform with the UHS-I UHS Speed Class 3 standard
- Keep the memory card out of reach of children to prevent swallowing.





### Speed Class during shooting

The memory card to use differs depending on the file format and the recording format.

Use memory cards compatible with the Speed Class or UHS Speed Class.

The recording may stop suddenly when a memory card not compatible with the required Speed Class is used.

Speed Class and UHS Speed Class are the speed specification regarding continuous writing. Check the display on the label and other information on the memory card.

File format	Recording bit rate or recording function	Supported memory cards and Speed Classes	Example of card display
MOV/MP4	200 Mbps, 150 Mbps, 100 Mbps, Super slow recording	• SDXC memory card with UHS Speed Class 3	
	72 Mbps, 50 Mbps	• SDXC memory card with Speed Class 10	 CLASS 
AVCHD	All	• SD card with Speed Class 4 or better	 CLASS 

#### When the file format is MOV or MP4

- SDXC memory cards can be used. SDHC memory cards cannot be used.

## Preventing unintentional erasing

Writing, erasing and formatting data is prohibited by setting the write-protection switch **A** of the memory card to the LOCK side.

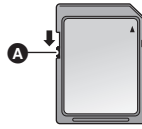

## Status of the card access lamp and memory card

Card access lamp	Memory card status	
Orange (illuminated)	Recording target	Both loading/writing are permitted. Current recording target.
Green (illuminated)	Recording possible	Both loading/writing are permitted.
Orange (flashing)	Accessing card	Loading/writing are currently being performed.
Orange (rapidly flashing)	Recognizing memory card	The memory card is being recognized.
	Error	An error has occurred. This will flash even if the memory card is not inserted when an error has occurred.
Green (slowly flashing)	No remaining recording capacity	No recording capacity left on the memory card. Only loading is possible.
	Write-protected	The write-protection switch of the memory card is set to the LOCK side.
	Recording not possible	It cannot record with the recording format that is currently set. Change the recording format or use a memory card compatible with the recording format to record.
Off	No memory card inserted	A memory card has not been inserted.
	Illegal format	It is not the correct format. Reformat the card.
	Card not supported	This is a card that cannot be used with the unit, such as MMC (Multi Media Card).
	During card reader mode	The card 1 access lamp/card 2 access lamp turns off when not accessing.



## Inserting/removing the memory card

### Inserting the memory card

The memory card to use with the unit should always be formatted on the unit. (→ 41)

- Formatting the memory card will erase all of the recorded data which cannot be restored.

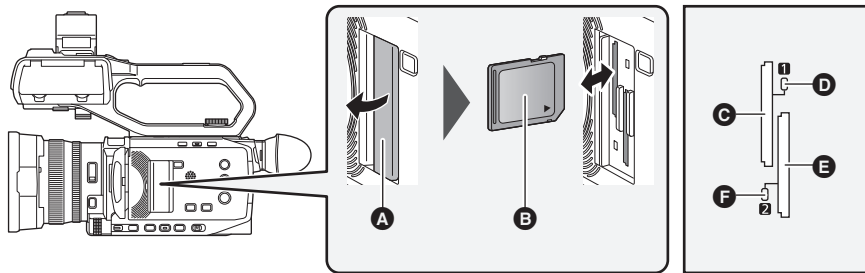

- A** Card slot cover
- B** Label side
- C** Card slot 1
- D** Card 1 access lamp
- E** Card slot 2
- F** Card 2 access lamp

#### 1 Open the card slot cover.

#### 2 Insert the memory card into the card slot.

- Card slot 1 and card slot 2 can each insert one memory card.
- With the label facing in the direction indicated in the diagram, push in until there is a click.  
Do not force or apply excess force when inserting the memory card.

#### 3 Close the card slot cover.

### Removing the memory card

#### 1 Open the card slot cover.

- Confirm that the card access lamp is not flashing in orange.
- Data is being written/loaded when the card access lamp is flashing in orange, so do not remove the memory card.

#### 2 Press in the memory card further into the main unit and let go.

- Pull the memory card straight out when it is released from the card slot.

#### 3 Close the card slot cover.

### Cautions when using or storing

- Do not touch the connecting terminal section at the rear of the memory card.
- Avoid high temperature and humidity.
- Avoid water droplets.
- Avoid charging with electricity.  
Use or store the memory card with the card inserted into the unit and with the slot cover closed.

### Formatting the memory card

Before recording with a memory card that is to be used for the first time in this unit, format it.

All data will be deleted when the card is formatted. Save any important data to a computer, etc. (→ 170)

- When using 2 memory cards, you must format both of the memory cards.

#### 1 Select the [RECORDING] menu → [FORMAT MEDIA] → [SLOT1]/[SLOT2].

#### 2 When the confirmation message is displayed, select [SET].

#### 3 When the completion message is displayed, select [↵].

#### NOTE

- Do not turn this unit off or remove the memory card, while formatting. Do not expose the unit to vibrations or shock.
- This function can be operated also by touching the LCD monitor.
- It may take few seconds after closing the completion message until it can record.

**Format the cards using this unit. (Do not format using other devices, such as a computer, etc. Doing so may make the cards unusable in this unit.)**

## Recording time of the memory card

- Memory cards are only mentioned with their main memory size. The stated times are the approximate recordable times for continuous recording.
- If recording for long periods, prepare batteries for 3 or 4 times the period you wish to record for. (→ 30)
- The recordable time may be reduced if recording with a lot of action is recorded or recording of short clip is repeated.
- The recordable times depends on the recording condition or memory card type to be recorded.
- For the resolutions, frame rates, and bit rates for [REC FORMAT], refer to page 105.
- Refer to page 39 for the memory cards compatible with the different file formats.

### When the file format is MOV

Recording format	Recording rate	Recording capacity	
		64 GB	128 GB
UHD	200 Mbps	Approx. 40 min	Approx. 1 h 20 min
	150 Mbps	Approx. 55 min	Approx. 1 h 50 min
	100 Mbps	Approx. 1 h 20 min	Approx. 2 h 40 min
FHD	200 Mbps	Approx. 40 min	Approx. 1 h 20 min
	100 Mbps	Approx. 1 h 20 min	Approx. 2 h 40 min
	50 Mbps	Approx. 2 h 40 min	Approx. 5 h 20 min

- “h” is an abbreviation for hour and “min” for minute.

#### NOTE

- With super slow recording, the recording time changes depending on the frame rate of the [REC FORMAT].
- File is split approximately every 3 hours for the data in MOV format.  
These are displayed as separate clips in the thumbnail screen. In addition, the clips recorded across 2 memory cards using the relay recording are displayed as separate clips.
- The recording is stopped once when the recording time reaches 10 hours, and recording is automatically resumed after few seconds. Image and audio during the pause will not be recorded. This includes the case of special recording, such as super slow recording or relay recording.  
With super slow recording, the recording time will be shorter than 10 hours.  
For the recording time for 1 clip when super slow recording, refer to page 124.
- In the interval recording, the recording is stopped once when the length of a clip reaches 10 hours, and recording is automatically resumed after few seconds.

**When the file format is MP4**

Recording format	Recording rate	Recording capacity	
		64 GB	128 GB
UHD	100 Mbps	Approx. 1 h 20 min	Approx. 2 h 40 min
	72 Mbps	Approx. 1 h 50 min	Approx. 3 h 40 min
FHD	50 Mbps	Approx. 2 h 40 min	Approx. 5 h 20 min

- “h” is an abbreviation for hour and “min” for minute.

 **NOTE**

- File is split approximately every 3 hours for the data in MP4 format. These are displayed as separate clips in the thumbnail screen. In addition, the clips recorded across 2 memory cards using the relay recording are displayed as separate clips.
- The recording is stopped once when the recording time reaches 10 hours, and recording is automatically resumed after few seconds. Image and audio during the pause will not be recorded. This includes the case of special recording, such as relay recording.
- In the interval recording, the recording is stopped once when the length of a clip reaches 10 hours, and recording is automatically resumed after few seconds.

**When the file format is AVCHD**

■ For SDHC memory card

Recording format	Recording rate	Recording capacity			
		4 GB	8 GB	16 GB	32 GB
PS	25 Mbps	Approx. 19 min	Approx. 40 min	Approx. 1 h 20 min	Approx. 2 h 40 min
PH	21 Mbps	Approx. 21 min	Approx. 46 min	Approx. 1 h 30 min	Approx. 3 h
HA	17 Mbps	Approx. 30 min	Approx. 1 h	Approx. 2 h	Approx. 4 h 10 min
PM	8 Mbps	Approx. 1 h	Approx. 2 h	Approx. 4 h 15 min	Approx. 8 h 30 min

■ For SDXC memory card

Recording format	Recording rate	Recording capacity	
		64 GB	128 GB
PS	25 Mbps	Approx. 5 h 20 min	Approx. 11 h
PH	21 Mbps	Approx. 6 h	Approx. 12 h 30 min
HA	17 Mbps	Approx. 8 h 30 min	Approx. 17 h
PM	8 Mbps	Approx. 17 h 10 min	Approx. 35 h

- “h” is an abbreviation for hour and “min” for minute.

 **NOTE**

- File is split approximately every 4 GB for the data in AVCHD format. These are displayed as one clip in the thumbnail screen. However, the clips recorded across 2 memory cards using the relay recording are displayed as separate clips.
- The recording is stopped once when the recording time reaches 10 hours, and recording is automatically resumed after few seconds. Image and audio during the pause will not be recorded. This includes the case of special recording, such as relay recording.
- Protection is automatically released on memory cards locked with AVCHD protection such as DVD recorders.

## Handling the recording data

### Folder structure example of a memory card

Various important information is contained in the recording data, and it is linked with the folder structure and management files as shown in the figure. If such information is changed or deleted even partially, an error such as that the data cannot be recognized or the recording becomes impossible may occur.

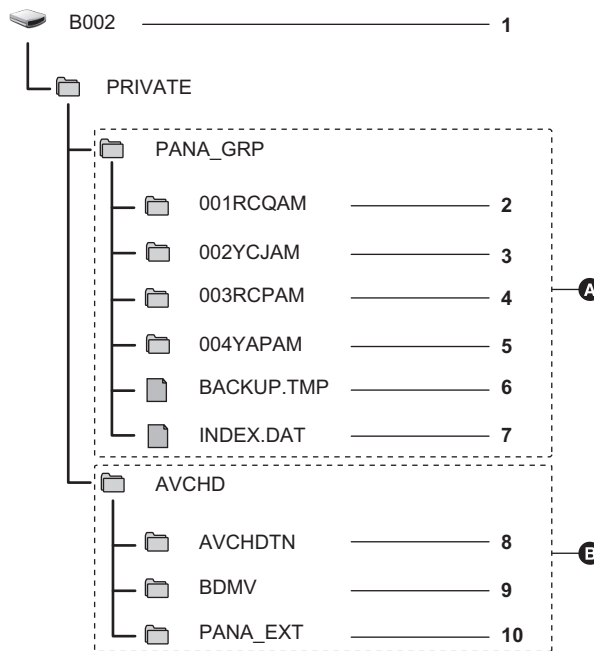

- A** MOV/MP4 format
- B** AVCHD format

- 1** Volume label of the memory card
- 2** Video data in MOV format: UHD (3840×2160), 29.97p MOV (audio: LPCM)
- 3** Video data in MOV format: FHD (1920×1080), 59.94i MOV (audio: LPCM)
- 4** Video data in MP4 format: UHD (3840×2160), 29.97p MP4 (audio: AAC)
- 5** Video data in MP4 format: FHD (1920×1080), 59.94p MP4 (audio: AAC)
- 6** Management file 1
- 7** Management file 2
- 8** Thumbnail of video data
- 9** Video data in AVCHD standard (00000.MTS, etc.)
- 10** Management folder

#### NOTE

- Do not erase a folder or file on the memory card with a computer. It may make it impossible to load on the unit.
- If data is recorded to the memory card with a computer, an error may occur such as an inability to recognize or record to the memory card with the unit.
- The memory card to use with the unit should always be formatted on the unit.

### Volume label of the memory card

#### ■ When the file format is MOV or MP4

The value set in the [RECORDING] menu → [CLIP NAME] is stored in the volume label in the CAM INDEX + NEXT CARD COUNT format when the memory card is formatted. Once it is stored, [NEXT CARD COUNT] will increase by one. The CARD COUNT that is stored is also used for the CARD number of the MOV format/MP4 format file name.

#### NOTE

- When recording to the memory card that CAM INDEX + CARD COUNT is not stored in the volume label, the value set in the [RECORDING] menu → [CLIP NAME] is automatically stored in the volume label, and [NEXT CARD COUNT] will increase by one.

#### ■ When the file format is AVCHD

“CAM\_SD” is stored in the volume label.

**Folder name of the MOV format/MP4 format video data**

The fourth through eighth characters of the folder name differ depending on the setting of the unit.

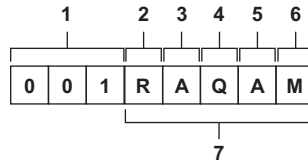

- 1 Folder number**  
001 to 999 (sequential number)
- 2 Number of pixels**  
R: 3840×2160  
Y: 1920×1080
- 3 Frame rate**  
A : 59.94 fps  
B : 50.00 fps  
C : 29.97 fps  
D : 25.00 fps  
F : 23.98 fps
- 4 Video format**  
P : Progressive recording (MP4, AAC)  
Q : Progressive recording (MOV, LPCM)  
I : Interlace recording (MP4, AAC)  
J : Interlace recording (MOV, LPCM)
- 5 Fixed values**  
A
- 6 Recording setting**  
M : Standard recording (card slot 1 for simultaneous recording)  
T : Simultaneous recording (card slot 2 for simultaneous recording)
- 7 Recording format information**

■ **When the folder name is 001RAQAM**

Following video data is saved in the folder.

- Number of pixels: 3840×2160
- Frame rate: 59.94 fps
- Video format: Progressive recording (MOV, LPCM)

**File name of the MOV format/MP4 format video data**

The format of the file name is as follows.

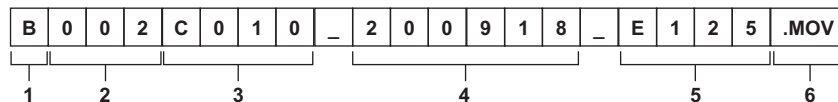

- 1 CAM INDEX**  
One character from upper case A to Z.  
● An INDEX assigned to each camera. Set with the [RECORDING] menu → [CLIP NAME] → [CAM INDEX].
- 2 CARD number**  
001 to 999  
● This is the number assigned to each memory card. The CARD COUNT stored in the volume label of the memory card is assigned.
- 3 Clip number**  
C001 to C999  
● This is a sequential number assigned to each recording on the memory card. The number returns to C001 when the memory card is formatted.  
It will also return to C001 for the one after C999.  
The clip number is maintained even when the folder is split or when the clip is deleted.
- 4 Date**  
Last 2 digits of year + 2 digits of month + 2 digits of date when the recording is started.
- 5 Hashtag generated from the serial number**  
4-digit number or alphabet
- 6 File format**  
[.MOV] or [.MP4]

**NOTE**

- The clip name of the card slot 2 will be the same as the clip name of the card slot 1 for the simultaneous recording.

### About the number of clips that can be recorded to a memory card

File format	Number of clips
MOV	Approx. 4000
MP4	<ul style="list-style-type: none"> <li>• The total number of clips for MOV and MP4.</li> </ul>
AVCHD	Approx. 3900

- When multiple file formats are recorded to a single memory card, the number will be less than that shown above.

#### ■ About MOV/MP4 folders

The maximum number of folder and the folder number is 999. The recording is prohibited when it reaches 999 even if number in between is open.

- The upper limit for the number of clips that can be recorded in a single folder is 999. Once it reaches 999, a folder with sequential number added is newly created.

Also, a folder with sequential number added is newly created when the folder name is changed by changing the setting of the unit.

The folder number will return to 001 when the memory card is formatted.

#### ■ About AVCHD playlists

When recording with AVCHD, playlists are generated. The upper limit for the number of clips that can be recorded in a single playlist is 99.

- A new playlist is generated in the following cases.
  - When the [REC FORMAT] is changed for recording
  - When recording with interval recording
  - When a memory card that has been used in this unit is recorded to with another device
  - When the total recording time in a single playlist reaches 11 hours 30 minutes
- The upper limit for the number of playlists is 900. Recording is prohibited when the number of playlists reaches 900.

## Setting of time data

The unit provides time code, user bits, and date and time (real time) data as time data, and records in each frame synchronized with the video. The time data is also recorded as the clip meta data.

### Definition of time data

#### ■ Time code

[FREE RUN] and [REC RUN] can be switched with the [RECORDING] menu → [TC/UB] → [FREE/REC RUN].

- **[FREE RUN]:** Advances regardless of the operation mode. It is advancing even when the power is turned off, so it can be treated equally as time.
- **[REC RUN]:** Advances only while recording. Recording is started with the value continuing from the last time code recorded previously.

#### NOTE

- The [REC RUN] will not be a continuous value for following cases.
  - When deleting recorded clips
  - When recording is interrupted due to a malfunction of [REC WARNING], etc. during recording.
- It will be fixed to [FREE RUN] when pre-recording is enabled. (→ 129)
- [FREE RUN] is fixed when the background recording function is enabled. (→ 131)
- [REC RUN] is fixed when the super slow recording function is enabled. (→ 124)
- It will be fixed to [REC RUN] when the interval recording function is enabled. (→ 132)

#### ■ User bits

User bits are built-in. User bits are recorded in the clip.

The user setting value, time, date, time code, and frame rate information of shooting, and the clip name can be selected for recording.

The value at the time when the recording has started is recorded in the user bits of the clip meta data.

#### ■ Counter

When you display the counter by either pressing the USER button assigned to [COUNTER] or touching the USER button icon, the counter value is displayed in the time code display area of the viewfinder/LCD monitor screen.

Counter value is displayed as "hour:minute:second.frame".

Furthermore, while the counter value is being displayed, you can reset the counter value by either pressing the USER button assigned to [RESET] or touching the USER button icon.

Either of the following settings can be set in the [RECORDING] menu → [REC COUNTER].

- **[TOTAL]:** Counting continues cumulatively until the counter value is reset. The counter value will be maintained even if the memory card is replaced or the power is turned off.
- **[CLIP]:** Clears the counter value and starts counting from 0 each time recording starts. You can shoot while always checking the recording time of the clip you are currently shooting.

#### ■ Date/time (real time)

- The internal clock is the standard for the free run time code count while the power is turned off, for the user bits time, and for the date data. Also, it will be the reference for the file generation time and file name when the clip is recorded.
- The free run time code is reset if the built-in battery is exhausted.

#### NOTE

- Switch the display on the camera image screen by either pressing the USER button assigned to [COUNTER] or touching the USER button icon.

### User bits settings

Set the user bits to be recorded.

#### 1 Select the user bits to record in the [RECORDING] menu → [TC/UB] → [UB MODE].

[FRAME RATE]	Records the frame rate information of the shooting. Use with this setting when using the frame rate information of the user bits with an editing device such as a computer.
[USER]	Records the user bits set in the [RECORDING] menu → [TC/UB] → [UB PRESET]. The setting value is maintained even if the power is turned off. For details, refer to "How to input user bits". (→ 48)
[TIME]	Records the hour, minute, and second of the date and time measured with the internal clock.
[DATE]	Records the last 2 digits of year, month, date, and hour of the date and time measured with the internal clock.
[TC]	Records the value for the time code as users bits.
[CLIP NAME]	Records the value that CAM INDEX (one character) and CARD COUNT (3-digit number) both converted to ASCII character code.

### How to input user bits

By setting user bits, information such as memos (date, time) up to 8 digits long (hexadecimal) can be recorded.

- 1 Select the [RECORDING] menu → [TC/UB] → [UB MODE] → [USER].
- 2 Select the [RECORDING] menu → [TC/UB] → [UB PRESET].  
The user bits setting screen is displayed.
- 3 Set the user bits.
  - Set 2 digits each.
  - You can reset to [00] by either pressing the USER button assigned to [RESET] or touching the USER button icon.
- 4 Confirm the setting value of the user bits.
  - The setting value is confirmed when last 2 digits are set.

### Memory function of the user bits

The setting content of the user bits is automatically recorded and maintained even if the power is turned off.

#### Frame rate information

The relationship between frame rate, image pull-down, time code, and user bits is as follows.

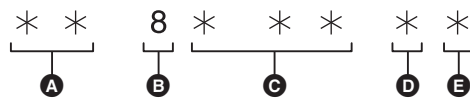

- A Verification information on the right-hand 6 digits
- B Fixed values
- C Frame rate
- D Camera video mode
- E REC mark

#### ■ Camera video mode

The display of the camera video mode differs depending on the setting of following menus.

- The [SYSTEM] menu → [REC FORMAT]
- The [SYSTEM] menu → [SUPER SLOW]

[FREQUENCY]	Frame rate of [REC FORMAT]	Display of camera video mode	
		When [SUPER SLOW] is [ON]	When [SUPER SLOW] are [OFF]
[59.94Hz]	23.98p	D	C
	29.97p	9	8
	59.94p	9	8
	59.94i	—	0
[50.00Hz]	25.00p	B	A
	50.00p	B	A
	50.00i	—	2

### Setting the time code

- 1 Select the [SYSTEM] menu → [FREQUENCY] → [59.94Hz]/[50.00Hz].
- 2 From the [SYSTEM] menu → [FILE FORMAT]/[REC FORMAT], select the recording format.
- 3 Select the [RECORDING] menu → [TC/UB] → [DF/NDF] → [DF]/[NDF].

Item	Time code display example	Description
[DF]	TCG 00:00:00.00	Time code is compensated in accordance with the actual time. It is mainly used for broadcasting such as TV programs.
[NDF]	TCG 00:00:00:00	It will not compensate the time code. (There will be a difference from the actual time)

- 4 Select the [RECORDING] menu → [TC/UB] → [TC PRESET].  
The [TC PRESET] screen is displayed.
- 5 Set the time code.  
You can reset the time code to 0 by either pressing the USER button assigned to [RESET] or touching the USER button icon.
- 6 Confirm the setting value of the time code.  
The setting value is confirmed when last 2 digits are set.



### ■ Setting range of time code

The range of the time code that can be set differs depending on the frame rate of [REC FORMAT].

[FREQUENCY]	Frame rate of [REC FORMAT]	Range of the time code that can be set
[59.94Hz]	59.94p, 29.97p, 59.94i	00:00:00:00 to 23:59:59:29
	23.98p	00:00:00:00 to 23:59:59:23
[50.00Hz]	50.00p, 25.00p, 50.00i	00:00:00:00 to 23:59:59:24

#### NOTE

- The set change is not reflected if the time code setting screen is closed without confirming the setting value.
- Set the number of frames with a value that is a multiple of 4 when the frame rate of [REC FORMAT] is set to 23.98p. The recorded time code will shift with any other value.
- In the following cases, [DF/NDF] is fixed to [NDF]:
  - When the frame rate of the [REC FORMAT] is 23.98p
  - When interval recording is enabled

#### Time code function during battery replacement

The operation of the time code generator will continue by the backup mechanism functioning even when replacing the battery.

The time code of the free run may shift when any item in the [SYSTEM] menu → [FREQUENCY], [FILE FORMAT], or [REC FORMAT] is changed.

After turning on the power again with the power button, check the time code and set again if necessary.

#### Time code in super slow recording

The time code is fixed to [REC RUN] when the super slow recording function is enabled.

- The time code output from the <SDI OUT> terminal\* or the <HDMI> terminal proceeds at 1× speed starting at the same time as recording.

\* Available for use when using 

## Assigning function to the USER buttons

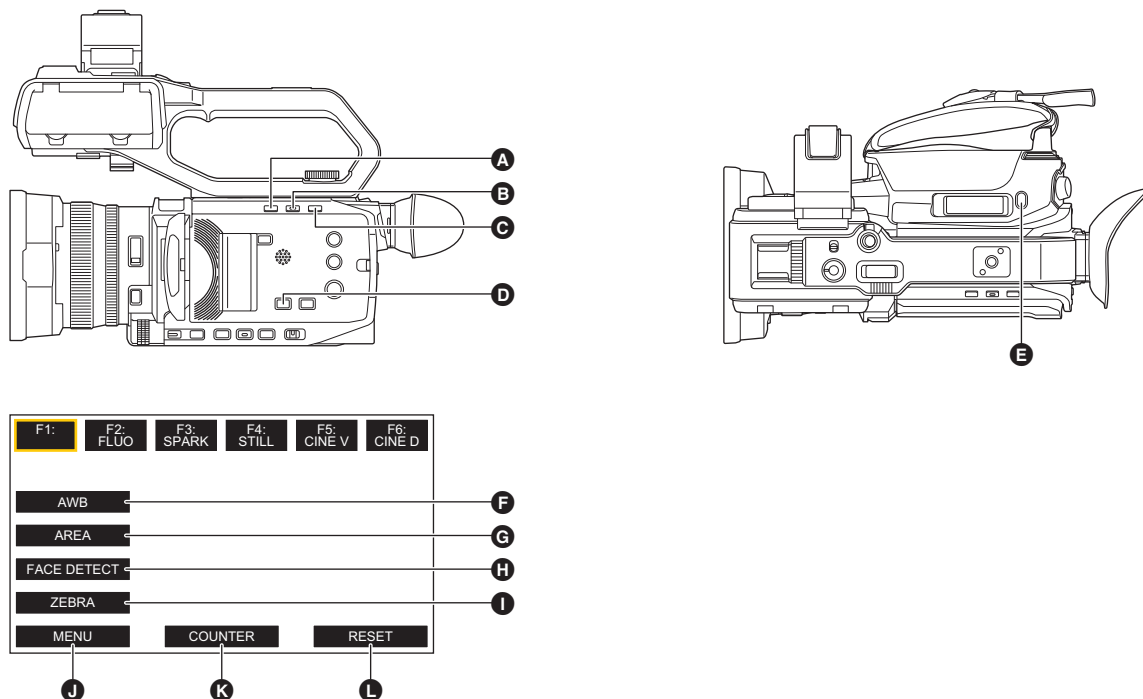

- A** <USER1> button
- B** <USER2> button
- C** <USER3> button
- D** <USER4> button
- E** <USER5> button

- F** [USER6] button icon
- G** [USER7] button icon
- H** [USER8] button icon
- I** [USER9] button icon
- J** [USER10] button icon
- K** [USER11] button icon
- L** [USER12] button icon

Selected function can be assigned to the USER buttons.

The USER buttons have 5 USER buttons on the unit (<USER1> to <USER5> buttons) and 7 USER button icons displayed on the LCD monitor ([USER6] to [USER12] button icons).

The <USER1> to <USER5> buttons can be used as the USER buttons when the camera image screen is displayed.

The [USER6] to [USER12] button icons can be used as the USER buttons when the operation icon screen is displayed.

**1** Select the function to assign to each in the [CAMERA] menu → [USER SW] → [USER1] to [USER12].

### ■ Functions assigned to the USER buttons in the factory setting

USER button/USER button icon	Function (USER button icon display)
<USER1> button	[LEVEL GAUGE]
<USER2> button	[BACKLIGHT]
<USER3> button	[O.I.S.]
<USER4> button	[AE LEVEL]
<USER5> button	[REC CHECK]
[USER6]	[AWB] ([AWB])
[USER7]	[AREA] ([AREA])
[USER8]	[FACE DETECT] ([FACE DETECT])
[USER9]	[ZEBRA] ([ZEBRA])
[USER10]	[MENU] ([MENU])
[USER11]	[COUNTER] ([COUNTER])
[USER12]	[RESET] ([RESET])

### Functions assigned to USER buttons

Item (USER button icon display)	Description
[INHIBIT] ([INHIBIT])	Disables assignment of functions.
[AWB] ([AWB])	Assigns the automatic white balance function.
[DRS] ([DRS])	Assigns the dynamic range stretcher function.
[FBC] ([FBC])	Switches enable/disable of the flash band compensation function.

### Chapter 3 Preparation — Assigning function to the USER buttons

Item (USER button icon display)	Description
[ONE PUSH AF] ([ONE PUSH AF])	Assigns the one-push auto focus function.
[S.GAIN] ([S.GAIN])	Assigns the function that switches to super gain.
[AREA] ([AREA])	Assigns the area function.
[ATW] ([ATW])	Switches enable/disable of the auto tracking white balance function.
[ATW LOCK] ([ATW LOCK])	Fixes the value of the white balance. Press the USER button again or touch the USER button icon to resume the operation of the auto tracking white balance. Enable when the auto tracking white balance is operating.
[SPOTLIGHT] ([SPOTLIGHT])	Switches enable/disable of the auto iris control function for the spot light.
[BACKLIGHT] ([BACKLIGHT])	Switches enable/disable of the auto iris control function for the backlight compensation.
[AE LEVEL] ([AE LEVEL])	Switches enable/disable of the AE level function.
[Y GET] ([Y GET])	Assigns the function that displays the luminance level of the frame area displayed near the center.
[O.I.S.] ([O.I.S.])	Switches enable/disable of the optical image stabilizer function.
[i.ZOOM] ([i.ZOOM])	Assigns the zoom function to minimize image distortion.
[D.ZOOM] ([D.ZOOM])	Switches enable/disable of digital zoom. Zooms in on the field angle by 2x, 5x, and 10x vertically and horizontally each time the USER button is pressed or the USER button icon is touched.
[IR REC] ([IR REC])	Switches enable/disable of IR recording.
[FAST ZOOM] ([FAST ZOOM])	Speeds up the zoom speed when the zoom lever is pushed in all the way.
[PRE REC] ([PRE REC])	Switches enable/disable of pre-recording.
[SUPER SLOW] ([SUPER SLOW])	Switches enable/disable of the super slow recording function.
[BACKGR PAUSE] ([BACKGR PAUSE])	Assigns the function that stops the background recording of card slot 2. Press and hold the USER button to which [BACKGR PAUSE] is assigned for approximately 5 seconds or touch and hold the USER button icon for approximately 5 seconds and release to stop background recording.
[REC CHECK] ([REC CHECK])	Automatically plays back the last approximately 3 seconds of the previously shot clip.
[DEL LAST CLIP] ([DEL LAST CLIP])	Deletes the clip last shot.
[FOCUS ASSIST] ([FOCUS ASSIST])	Switches enable/disable of the focus assist function.
[WFM] ([WFM])	Switches the display of the waveform monitor. The waveform display is selected in the [VIDEO OUT/LCD/VF] menu → [EI ASSIST] → [WFM MODE].
[ZEBRA] ([ZEBRA])	Switches display/hide of zebra patterns.
[LEVEL GAUGE] ([LEVEL GAUGE])	Switches display/hide of the level gauge.
[LEVEL GAUGE SET] ([LEVEL GAUGE SET])	Sets the current horizontal and vertical direction as the reference value of the level gauge.
[LCD/VF DETAIL] ([LCD/VF DETAIL])	Adjusts the intensity for the contour of the video in the viewfinder or LCD monitor to make it easier to focus.
[FACE DETECT] ([FACE DETECT])	Switches enable/disable of the face detection AE&AF function.
[MENU] ([MENU])	Switches display/hide of the menu.
[LOAD SETUP FILE] ([LOAD SETUP FILE])	Selects the setup file saved on the memory card to load on the unit.
[LCD BACKLIGHT] ([LCD BACKLIGHT])	Switches the brightness of the LCD monitor. Each time you either press the USER button or touch the USER button icon, the brightness switches in the order [0], [1], [2], [-1].
[CARD READER MODE] ([CARD READER MODE])	Switches enable/disable of the card reader mode function (USB mass storage function). • Release the connection to enable the card reader mode when connected to a network via a wireless LAN. (The unit returns to the original setting when the card reader mode is disabled.)
[STREAMING START] ([STREAMING START])	Starts/stops streaming from the unit. Streaming starts only during RTMP streaming.
[COUNTER] ([COUNTER])	Switches the time code display. (Time code display/user bits display/counter display/no display)
[RESET] ([RESET])	Resets the counter value.
[REAR RING] ([REAR RING])	The rear ring operation is switched. (Zoom/iris/iris and AE level)

#### NOTE

- The following functions are disabled the next time you turn the unit on after turning it off with the power.
  - [FBC], [S.GAIN], [AREA], [ATW LOCK], [SPOTLIGHT], [BACKLIGHT], [Y GET], [D.ZOOM], [FAST ZOOM], [REC CHECK], [DEL LAST CLIP], [FOCUS ASSIST], [WFM], [CARD READER MODE], [STREAMING START]
- The following functions cannot be set when IR recording is enabled.
  - [AWB], [ATW], [ATW LOCK], [SPOTLIGHT], [BACKLIGHT], [AE LEVEL], [FACE DETECT]
- In auto mode, the following functions cannot be set:
  - [AWB], [FBC], [ONE PUSH AF], [ATW], [FOCUS ASSIST]
- USER button functions can also be set from the following menus:

USER button functions	Menu settings
[DRS]	[SCENE FILE] menu → [DRS]
[AE LEVEL]	[SCENE FILE] menu → [AE LEVEL]
[O.I.S.]	[CAMERA] menu → [SW MODE] → [O.I.S.]
[i.ZOOM]	[CAMERA] menu → [SW MODE] → [i.ZOOM]
[IR REC]	[CAMERA] menu → [SW MODE] → [IR REC]
[PRE REC]	[RECORDING] menu → [PRE REC]

### Chapter 3 Preparation — Assigning function to the USER buttons

USER button functions	Menu settings
[SUPER SLOW]	[SYSTEM] menu → [SUPER SLOW]
[LEVEL GAUGE]	[VIDEO OUT/LCD/VF] menu → [LEVEL GAUGE] → [LEVEL GAUGE]
[LCD/VF DETAIL]	[VIDEO OUT/LCD/VF] menu → [FOCUS ASSIST] → [DETAIL]
[LOAD SETUP FILE]	[OTHERS] menu → [FILE] → [SETUP FILE(SD CARD)] → [LOAD]
[LCD BACKLIGHT]	[VIDEO OUT/LCD/VF] menu → [LCD] → [BACK LIGHT]
[CARD READER MODE]	[OTHERS] menu → [USB DEVICE] → [CARD READER MODE]
[STREAMING START]	[NETWORK] menu → [STREAMING] → [START]
[REAR RING]	[CAMERA] menu → [SW MODE] → [REAR RING]

#### Checking the function assigned to the USER buttons

You can check the function assigned to the USER buttons in the SWITCH screen of the mode check. For details, refer to “Mode check display” (→ 165).

## Adjusting and setting the LCD monitor

### Using the LCD monitor

This unit is equipped with a 3.5-inch LCD monitor. Use either the viewfinder or the LCD monitor depending on your purpose and the shooting conditions.

#### 1 Open the LCD monitor.

The light goes on when the LCD monitor is opened. The light goes off when it is closed.

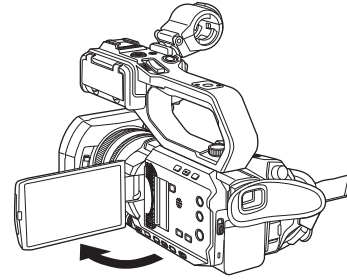

#### 2 Turn the LCD monitor to a comfortable viewing angle.

It can be turned towards the lens by 180° and in the forward direction by 90°.

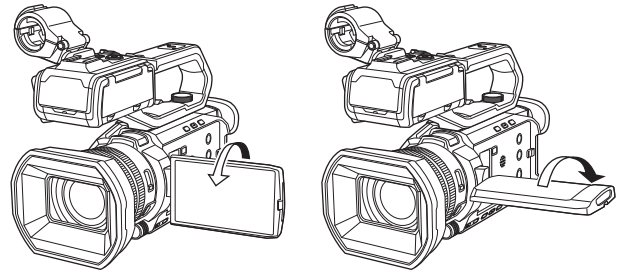

#### NOTE

- When closing the LCD monitor, be sure to close it firmly.
- Take care not to apply excessive force on the LCD monitor when it is opened. Doing so may result in a malfunction.
- The image brightness and color hue seen on the viewfinder and LCD monitor may be different from that seen on a TV monitor. The final check of the image should be done on a TV monitor.

### Adjusting the LCD monitor

#### ■ Adjusting brightness, contrast, color level, redness, and blueness

By setting the following items in the [VIDEO OUT/LCD/VF] menu → [LCD], you can adjust items such as brightness and contrast for the LCD monitor:

- [BRIGHTNESS]: Adjusts the brightness.
- [COLOR LEVEL]: Adjusts the density of the colors.
- [CONTRAST]: Adjusts the contrast.
- [RED TINT]: Adjusts the strength of red.
- [BLUE TINT]: Adjusts the strength of blue.

The adjustments of the LCD monitor do not affect the images output or recorded by the camera.

#### ■ Adjusting the backlight luminance

The following operations switch the luminance of the backlight of the LCD monitor:

- Set with the [VIDEO OUT/LCD/VF] menu → [LCD] → [BACK LIGHT].
- Each time you either press the USER button assigned to [LCD BACKLIGHT] or touch the USER button icon, the brightness switches in the order [0], [1], [2], [-1].

### Mirror shooting

When recording with the LCD monitor rotated towards the lens side, if the unit is set to the [VIDEO OUT/LCD/VF] menu → [LCD] → [SELF SHOOT] → [MIRROR], the image is displayed in reverse in left and right on the LCD monitor. This allows shooting as if looking at a mirror image. Note that only the display of the LCD monitor is horizontally reversed. The settings for mirror shooting do not affect the images output or recorded by the camera.

## Adjusting and setting the viewfinder

This unit is equipped with a 0.24-inch viewfinder. Use either the viewfinder or the LCD monitor depending on your purpose and the shooting conditions.

### Using the viewfinder

When the LCD monitor is difficult to use because the surroundings are bright, you can check the image using the viewfinder.

#### 1 Extend the viewfinder.

The viewfinder turns on when it is extended and turns off when retracted.

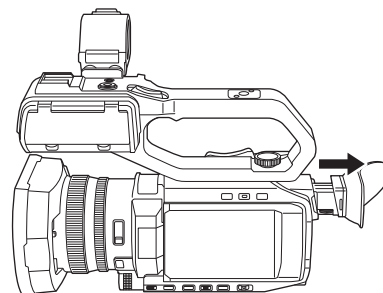

#### 2 Move the viewfinder in the vertical direction to adjust the screen to a comfortable angle.

The viewfinder can be elevated approximately 50°.

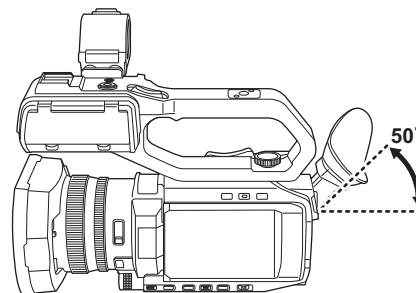

#### 3 Adjust the characters on the viewfinder screen so that they are clearly visible using the diopter adjustment dial **A**.

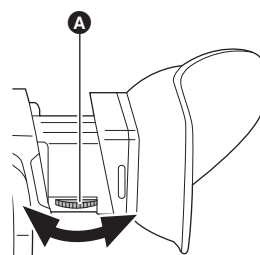

#### NOTE

- The image brightness and color hue seen on the viewfinder and LCD monitor may be different from that seen on a TV monitor. The final check of the image should be done on a TV monitor.

### Adjusting the viewfinder

#### ■ Adjusting brightness, contrast, color level, redness, and blueness

By setting the following items in the [VIDEO OUT/LCD/VF] menu → [VF], you can adjust items such as brightness and contrast for the viewfinder:

- [BRIGHTNESS]: Adjusts the brightness.
- [COLOR LEVEL]: Adjusts the density of the colors.
- [CONTRAST]: Adjusts the contrast.
- [RED TINT]: Adjusts the strength of red.
- [BLUE TINT]: Adjusts the strength of blue.

The adjustments for the viewfinder do not affect the images output or recorded by the camera.

#### ■ Switching between color and monochrome

The viewfinder screen can switch between a color display and monochrome display. Set the display with the [VIDEO OUT/LCD/VF] menu → [VF] → [VF COLOR].

## Tally lamp

---

When the handle unit ( **X2000** supplied, **X1500** optional) is attached to the unit, the tally lamp can be illuminated during recording.

### 1 Select the [OTHERS] menu → [HANDLE TALLY LED] → [ON].

- The tally lamp will flash when the unit is in the following status.
  - When the remaining recording capacity of the memory card or the remaining battery level is low (one time per second)
  - When the memory card has no more space to record (4 times per second)
  - When a warning such as a system error or a recording abnormality has occurred (4 times per second)

---

#### **NOTE**

- The tally lamp will not illuminate or flash when the [OTHERS] menu → [HANDLE TALLY LED] → [OFF] is set.

## Chapter 4      **Operation**

---

This chapter describes how to operate the screen of this unit, how to operate the menu, the structure of the menu, and details of the menu.



## Basic operation of the screen

### Major button operation and screen display

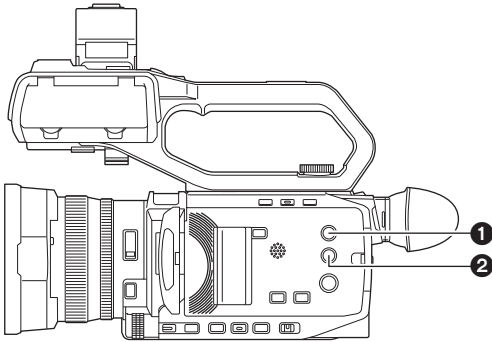

- ❶ <THUMBNAIL> button
- ❷ <DISP/MODE CHK> button

#### ■ <THUMBNAIL> button

Displays the thumbnail screen.

Playback, copy, delete, or protect of a clip can be performed.

For details about the thumbnail screen, refer to "Thumbnail operation". (→ 146)

#### ■ <DISP/MODE CHK> button

Press while the camera image screen is displayed to switch display/hide of most of the items.

Press the <DISP/MODE CHK> button for 1 second or more while displaying the camera image screen to display the STATUS screen of the mode check.

Each setting and the status of the unit can be confirmed.

For details about each screen of the mode check, refer to "Mode check display". (→ 165)

## Major button operation and switching screen

The screens switch as shown below when you press the <DISP/MODE CHK> button, <EXIT> button, <THUMBNAIL> button, or multial.

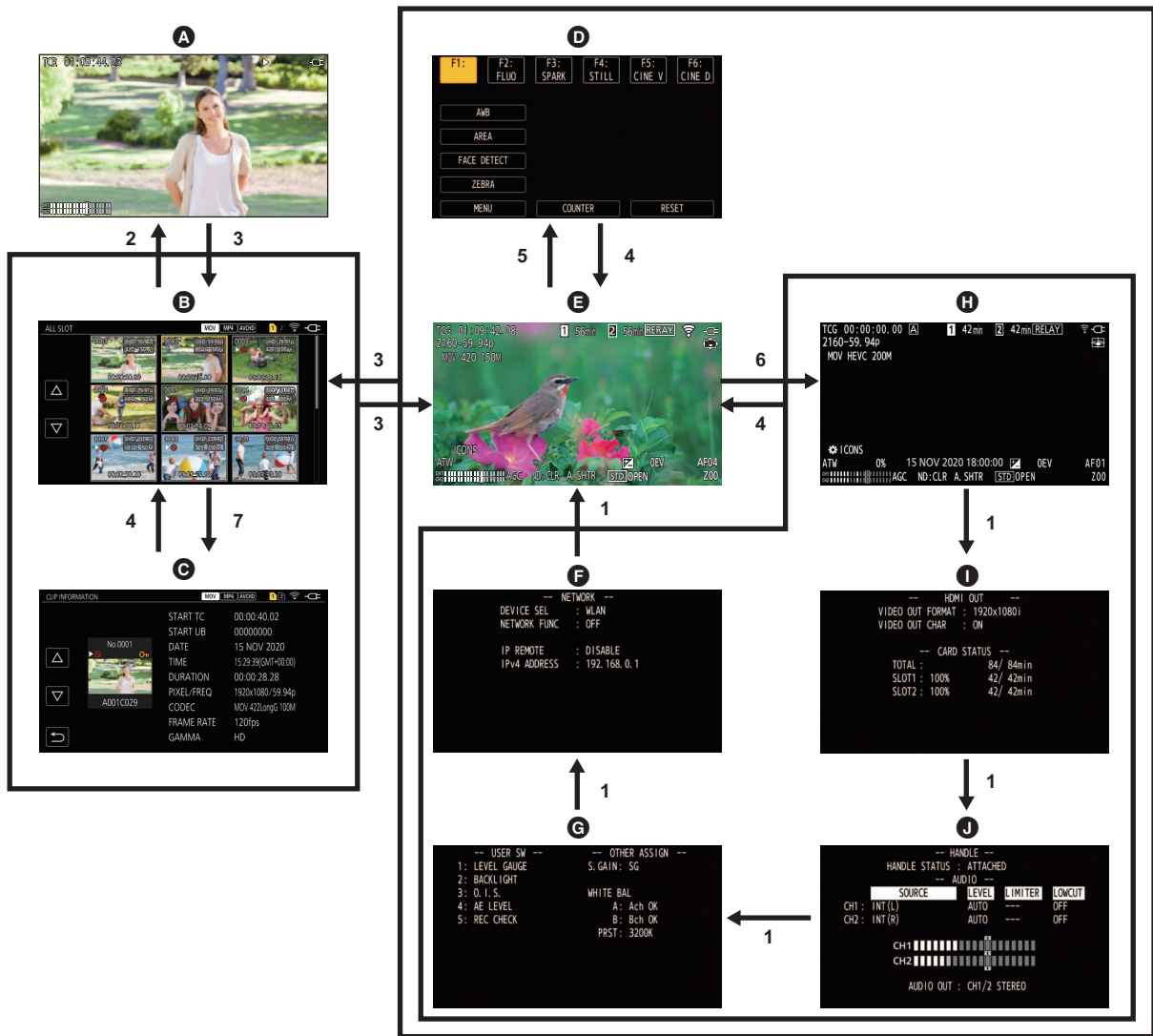

- Ⓐ Playback screen
- Ⓑ Thumbnail screen
- Ⓒ Clip information
- Ⓓ Operation icon screen
- Ⓔ Camera image screen

- Ⓕ Mode check NETWORK screen
- Ⓖ Mode check SWITCH screen
- Ⓗ Mode check STATUS screen
- Ⓘ Mode check FUNCTION screen
- ⓵ Mode check AUDIO screen

- 1 Press the <DISP/MODE CHK> button.
- 2 Press the multial.
- 3 Press the <THUMBNAIL> button.
- 4 Press the <EXIT> button.
- 5 Either touch and hold the screen for approximately 2 seconds, or press the multial when [ICONS] is displayed.
- 6 Press the <DISP/MODE CHK> button for 1 second or more.
- 7 Select the [THUMBNAIL] menu → [CLIP] → [INFORMATION].

### NOTE

- The camera image screen is displayed when the unit is turned on.
- The camera image screen is automatically displayed if recording starts while the thumbnail screen, playback screen or clip information is displayed.
- The playback screen is displayed if a clip is selected in the thumbnail screen.
- The thumbnail screen is displayed if the playback of the clip ends or playback is stopped.
- The unit changes to the camera image screen if any area other than the icon in the operation icon screen is touched. The camera image screen is displayed automatically after 5 seconds without any operation of the multial or touch operation in the operation icon screen.
- The camera image screen is automatically displayed after 5 seconds without operation of the <DISP/MODE CHK> button in each screen of the mode check.
- The screen will not switch to the camera image screen while the <DISP/MODE CHK> button is pressed.
- The camera image is displayed in the operation icon screen and each screen for the mode check.

## Operating each screen

---

### Camera image screen

Displays the shooting screen.

For details about the camera image screen, refer to “Screen status display”. (→ 159)

### Thumbnail screen

Playback, copy, delete, or protect of a clip can be performed.

For details about the thumbnail screen, refer to “Thumbnail operation”. (→ 146)

### Operation icon screen

You can select the scene file or operate the functions assigned to [USER6] through [USER12].

For details about the operation icon screen, refer to “Operation icon screen display”. (→ 142)

## Basic operation of the menu

The setting of the unit can be changed with the menu in accordance to the shooting scene or recording contents. Set data is written and saved in the main unit memory.

- There are 2 methods of operation: a method to operate with the multial, or a method to touch the LCD monitor.

### Configuration of the menu

[THUMBNAIL] menu	Performs confirmation or deleting of the recording clip. This menu can be set when the thumbnail screen is displayed.
[CAMERA] menu	Sets the basic functions of the camera. This menu cannot be set when the thumbnail screen is displayed.
[SCENE FILE] menu	Sets the setting regarding scene file. This menu sets the detailed image quality adjustment of the camera video. Also, selection of the scene file, writing the scene file data to the main unit memory, and loading from the main unit memory can be performed. This menu cannot be set when the thumbnail screen is displayed.
[AUDIO] menu	Sets the input/output function of audio.
[VIDEO OUT/LCD/VF] menu	Configures the settings for the external output, the information to display in the LCD monitor or viewfinder and the output format.
[RECORDING] menu	Sets the various items in the recording function.
[NETWORK] menu	Sets the setting regarding the network function.
[SYSTEM] menu	Configures the settings regarding the recording format of video and audio.
[OTHERS] menu	Configures the settings for writing/loading/initializing user files to the internal memory, and the basic unit settings.

## Displaying the menu

Displays the menu, and select the menu or item to set.

### 1 Press the <MENU> button.

The menu is displayed.

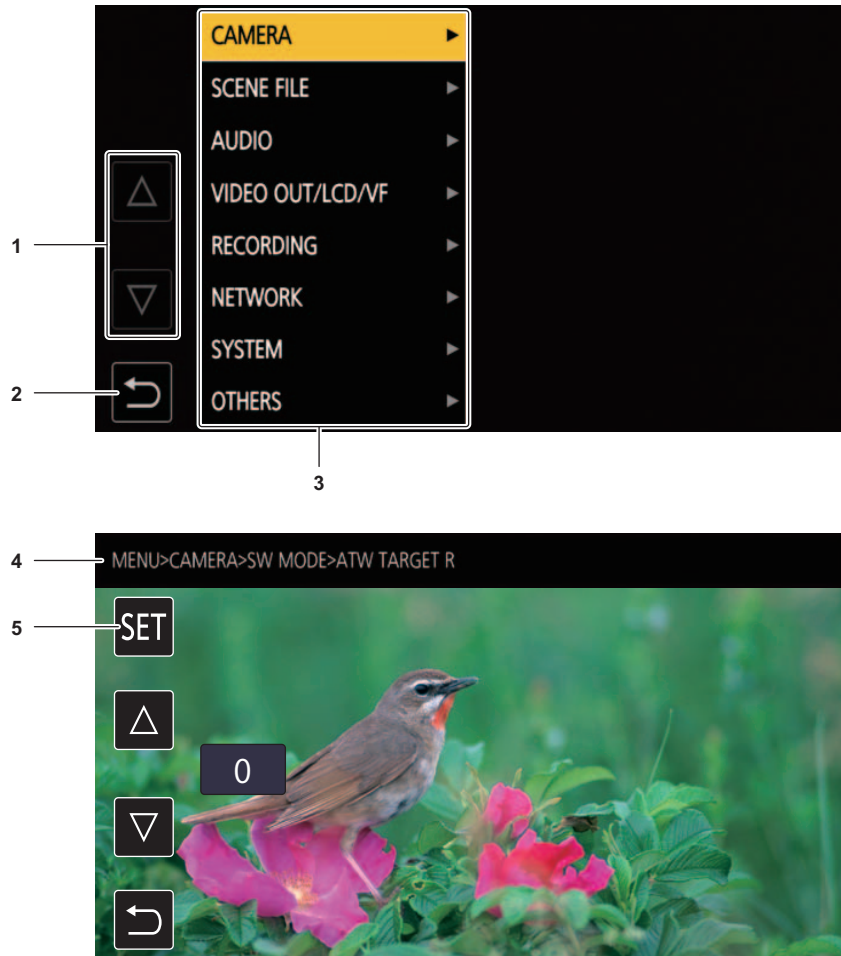

- 1 **[Δ]/[▽]**  
Switches the page or changes the value when selected.  
These button icons are not available if they cannot be changed.
- 2 **[↶]**  
Returns to one level higher from the current menu when selected.
- 3 **Menu**  
Moves to one level lower from the current menu, or to the setting screen when selected.
- 4 **Level display**  
Displays the path of the menu to the currently displayed screen.
- 5 **[SET]**  
Confirms the set value when selected.

#### NOTE

- The menu displayed in gray characters cannot be changed.

## Operating the menu

Various settings are possible from the menu.

There are 2 methods of operation: a method to operate with the multial, or a method to touch the LCD monitor.

### When operating with the multial

Operate the multial on the main unit by turning it in vertical direction or pushing it.

Fig. 1



Fig. 2



### 1 Press the <MENU> button.

The menu is displayed.

### 2 Select the menu to set.

- 1) Turn the multial to move the cursor to the menu to set.
- 2) Press the multial.

The lower level menu is displayed.

- The confirmation screen is displayed depending on the menu.
- Perform the similar operation if there is next level.
- In some menus, a screen to set the numeric value is displayed in the camera image screen (Fig. 2).
- In some menus, a message is displayed if a menu cannot be executed.
- Press the <EXIT> button to return to one level higher.

### 3 Select the item to set.

- 1) Turn the multial to move the cursor to the item to set.
- 2) Press the multial.
  - A check mark is displayed at the left of the set item. (Fig. 1)
  - Press the <EXIT> button to return to one level higher.

### 4 Press the <MENU> button to close the menu.

- Depending on the operating item, it will automatically return to the previous screen.

#### NOTE

- In screens for setting numbers (Fig. 2), you can change the numbers rapidly by pressing the multial down and holding it in the direction you want the change to be made.
- It is also possible to select/set operation icons, thumbnail displays, etc.

## When operating by touching the LCD monitor

Operate by touching the LCD monitor.

Fig. 1



Fig. 2

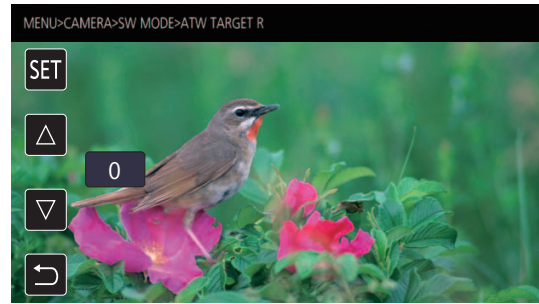

### 1 Press the <MENU> button.

The menu is displayed.

### 2 Select the menu to set.

The lower level menu is displayed.

- The confirmation screen is displayed depending on the menu.
- Perform the similar operation if there is next level.
- In some menus, a screen to set the numeric value is displayed in the camera image screen (Fig. 2).  
To change the numeric value, touch [Δ]/[▽] and change the setting value.
- In some menus, a message is displayed if a menu cannot be executed.
- Touch [Δ]/[▽] to switch the pages.  
The button icons cannot be touched if there are no more pages.
- To return to one level higher, touch [↶].

### 3 Select the item to set.

- Touch the item to set. A check mark is displayed at the left of the set item. (Fig. 1)
- To return to one level higher, touch [↶].

### 4 Exit from the menu by touching [↶], or pressing the <MENU> button.

- Depending on the operating item, it will automatically return to the previous screen.

## Initializing the menu

The menu can be returned to the factory setting condition.

### 1 Select the [OTHERS] menu → [MENU INITIALIZE].

### 2 Select [SET] when the confirmation message is displayed.

The setting value of the menu is returned to the factory setting.

## Menu settings

### [THUMBNAIL] menu

Performs confirmation or deleting of the recording clip.  
This menu can be set when the thumbnail screen is displayed.

### [PLAYBACK]

Sets the playback of recorded clips.  
[ALL SLOT] will always be selected when you switch from the camera image screen to the thumbnail screen.

### [CLIP SEL]

Selects a clip to be displayed on the thumbnail screen.

[ALL SLOT]	Displays the clips recorded on all the memory cards in each card slot.
[SLOT1]	Displays only the clips recorded on the memory card in card slot 1.
[SLOT2]	Displays only the clips recorded on the memory card in card slot 2.
[SAME FORMAT]	Displays only the clips recorded in the same format as the system format. Clips recorded in the same format means that each item of [FREQUENCY], [FILE FORMAT], and [REC FORMAT] in the [SYSTEM] menu matches the current setting status.

(Factory setting: [ALL SLOT])

### [RESUME PLAY]

Select if the playback is to start from the position the playback has stopped or not.

[ON]	Plays back from the position where playback has stopped.
[OFF]	Always starts the playback from the beginning of the clip.

(Factory setting: [OFF])

### [CLIP]

The clip can be protected or copied to a different memory card.

[PROTECT]	[SELECT]	Protect the clip so it is not mistakenly deleted. Select the clip to protect, and set the protect.
[DELETE]	[ALL]	Deletes all the clips displayed in the thumbnail screen. The clip that is not displayed in the thumbnail screen is not deleted.
	[SELECT]	Select the clip to delete, and delete it.
[COPY]	[ALL]	Copies all clips to a different memory card.
	[SELECT]	Selects the clip to copy, and copies the clip to a different memory card.
[INFORMATION]		Displays the detailed information of the clip.

### NOTE

- The clip recorded in MOV format/MP4 format cannot be copied.

### [DISPLAY]

Sets the display of the thumbnail screen.

### [DATA]

Selects the content to be displayed in the time code display area.

[START TC]	Displays the time code value at the start of the recording.
[CLIP NAME]	Displays clip names.

(Factory setting: [START TC])



**[CAMERA] menu**

Sets the basic functions of the camera.

This menu cannot be set when the thumbnail screen is displayed.

**[SW MODE]****[ZOOM RING]**

Sets the rear ring ❶ direction and zoom control when performing zoom operations.

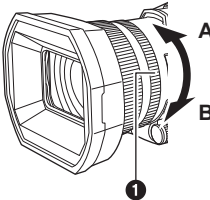
	[DOWN TELE]	Zooms in when turned towards the B side.
	[UP TELE]	Zooms in when turned towards the A side.

(Factory setting: [DOWN TELE])

**[IRIS RING]**

Sets the rear ring ❶ direction and iris control when adjusting the iris.

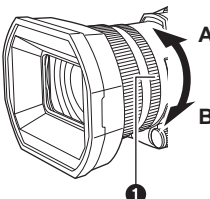
	[DOWN OPEN]	Iris opens when turned towards the B side.
	[UP OPEN]	Iris opens when turned towards the A side.

(Factory setting: [DOWN OPEN])

**[SUPER GAIN]**

Sets the super gain to be assigned to the USER button.

When [ALL] is selected, each time you either press the USER button or touch the USER button icon, the selection switches in the order [SUPER GAIN], [SUPER GAIN+], normal gain.

The items that can be set are as follows.

- [SUPER GAIN], [SUPER GAIN+], [ALL]

(Factory setting: [SUPER GAIN])

**[AGC LIMIT]**

Sets the maximum gain value during [AGC] operation.

The items that can be set are as follows.

- [3dB], [6dB], [12dB], [18dB], [24dB], [30dB]

(Factory setting: [30dB])

**[O.I.S.]**

Switches enable/disable of the optical image stabilizer function.

If [O.I.S.] is assigned to the USER button, pressing the USER button switches [ON]/[OFF].

For details about optical image stabilizer, refer to "Optical image stabilizer function". (→ 138)

[ON]	Enables the optical image stabilizer function.
[OFF]	Disables the optical image stabilizer function.

(Factory setting: [ON])

**[HYBRID O.I.S.]**

Switches enable/disable of the hybrid optical image stabilizer function.

For details about optical image stabilizer, refer to "Optical image stabilizer function". (→ 138)

[ON]	Enables the hybrid optical image stabilizer function.
[OFF]	Disables the hybrid optical image stabilizer function.

(Factory setting: [ON])

**[O.I.S. MODE]**

Switches the operation mode of the optical image stabilizer function.

[NORMAL]	Specifies the standard setting for a good balance of correction for large and small camera shake.
[PAN/TILT]	Specifies a setting appropriate for shooting that uses a lot of panning and tilting of the camera.
[STABLE]	Specifies a setting appropriate for fixing a composition to shoot a subject.

(Factory setting: [NORMAL])

**[ATW]**

You can set ATW (auto tracking white balance function) when the <WHITE BAL> button is pressed.

[Ach]	If you have pressed the <WHITE BAL> button to switch to [Ach], this is set to [ATW].
[Bch]	If you have pressed the <WHITE BAL> button to switch to [Bch], this is set to [ATW].
[PRE]	If you have pressed the <WHITE BAL> button to switch to "Preset", this is set to [ATW].
[OFF]	Even if you press the <WHITE BAL> button, [ATW] does not turn on.

(Factory setting: [OFF])

**[ATW SPEED]**

Sets the control speed of the auto tracking white balance function.

The items that can be set are as follows.

- [FAST], [NORMAL]

(Factory setting: [NORMAL])

**[ATW TARGET R]**

Make fine adjustments to the strength of red when converging with the auto tracking white balance operation.

The items that can be set are as follows.

- [-10]...[+10]

(Factory setting: [0])

**[ATW TARGET B]**

Make fine adjustments to the strength of blue when converging with the auto tracking white balance operation.

The items that can be set are as follows.

- [-10]...[+10]

(Factory setting: [0])

**[W.BAL PRESET]**

Sets the color temperature for when the <WHITE BAL> button is pressed to switch to "Preset".

The items that can be set are as follows.

- [3200K], [5600K], [VAR]

(Factory setting: [3200K])

**[W.BAL VAR]**

Sets the value of [VAR] in [W.BAL PRESET].

The setting can also be operated by the multial.

This is enabled when [W.BAL PRESET] is set to [VAR] and you press the <WHITE BAL> button to switch to "Preset".

The items that can be set are as follows.

- [2000K]...[15000K]

(Factory setting: [3200K])

**[H.ZOOM SPEED]**

Sets the zoom speed of the handle zoom.

The items that can be set are as follows.

- [1]...[7]

(Factory setting: [4])

**[i.ZOOM]**

When [i.ZOOM] is set to [ON], you can zoom to a maximum of approximately 48× (32× when recording with UHD) while maintaining the beauty of high-definition image quality.

[ON]	Enables the i.ZOOM function.
[OFF]	Disables the i.ZOOM function.

(Factory setting: [OFF])

**[REAR RING]**

Switches the rear ring operation.

[ZOOM]	Performs zoom operations with the rear ring.
[IRIS]	Adjusts the iris with the rear ring.
[IRIS/AE LEVEL]	Adjusts the iris or AE level with the rear ring.

(Factory setting: [ZOOM])

**NOTE**

- You can also either press the USER button assigned to [REAR RING] or touch the USER button icon to switch the setting of the rear ring operation.

**[AUTO SLOW SHTR]**

You can make images brighter by making the shutter speed slower in dark places. The slow shutter works when in the auto shutter mode.

The items that can be set are as follows.

- [ON], [OFF]
- (Factory setting: [OFF])

**NOTE**

- In the following case, this cannot be set.
  - When using the face detection/tracking AE&AF function
- The shutter speed changes to the following depending on the frame rate of [SYSTEM] menu → [REC FORMAT] and the ambient brightness.

Frame rate of [REC FORMAT]	Shutter speed
59.94p/59.94i/29.97p	1/30 or more
50.00p/50.00i/25.00p	1/25 or more
23.98p	1/24 or more

- When the shutter speed becomes 1/30, 1/25 or 1/24, the screen may be seen as if frames are missed and after images may appear.

**[AF SPEED]**

Sets the control speed of the auto focus function.

The items that can be set are as follows.

- [NORMAL], [SLOW]
- (Factory setting: [NORMAL])

**[AREA MODE]**

Assign the function that is performed within the area selected by touching the LCD monitor while shooting.

[INHIBIT]	Disables assignment of functions.
[FOCUS]	Assigns the auto focus function.
[IRIS]	Assigns the auto iris function.
[Y GET]	Assigns the brightness display function.
[FOCUS/IRIS]	Assigns the simultaneous operation of the [FOCUS] and [IRIS].
[FOCUS/Y GET]	Assigns the simultaneous operation of the [FOCUS] and [Y GET].

(Factory setting: [INHIBIT])

**[IR REC]**

Switches enable/disable of IR recording. (→ 133)

The items that can be set are as follows.

- [ON], [OFF]
- (Factory setting: [OFF])

**[IR REC COLOR]**

The color of IR recording recorded images can be switched.

The items that can be set are as follows.

- [WHITE], [GREEN]
- (Factory setting: [WHITE])

**[FACE DETECT/TRACKING MODE]**

Switches the behavior of focus and exposure compensation settings for the face detection/tracking AE&AF function.

[FACE DETECT/TRACKING AF]	After detecting faces, faces are tracked while auto focusing.
[FACE DETECT/TRACKING AE&AF]	After detecting faces, faces are tracked while auto focusing and automatically adjusting exposure.

(Factory setting: [FACE DETECT/TRACKING AE&AF])

**[USER SW]**

Sets the function to assign to the <USER1> to <USER5> buttons or the [USER6] to [USER12] button icons.

For details, refer to "Assigning function to the USER buttons". (→ 50)

Following functions can be assigned to [USER1] to [USER12].

- [INHIBIT], [AWB], [DRS], [FBC], [ONE PUSH AF], [S.GAIN], [AREA], [ATW], [ATW LOCK], [SPOTLIGHT], [BACKLIGHT], [AE LEVEL], [Y GET], [O.I.S.], [i.ZOOM], [D.ZOOM], [IR REC], [FAST ZOOM], [PRE REC], [SUPER SLOW], [BACKGR PAUSE], [REC CHECK], [DEL LAST CLIP], [FOCUS ASSIST], [WFM], [ZEBRA], [LEVEL GAUGE], [LEVEL GAUGE SET], [LCD/VF DETAIL], [FACE DETECT], [MENU], [LOAD SETUP FILE], [LCD BACKLIGHT], [CARD READER MODE], [STREAMING START], [COUNTER], [RESET], [REAR RING]

[USER1]	Sets the function to assign to the <USER1> button. (Factory setting: [LEVEL GAUGE])
[USER2]	Sets the function to assign to the <USER2> button. (Factory setting: [BACKLIGHT])
[USER3]	Sets the function to assign to the <USER3> button. (Factory setting: [O.I.S.])

[USER4]	Sets the function to assign to the <USER4> button. (Factory setting: [AE LEVEL])
[USER5]	Sets the function to assign to the <USER5> button. (Factory setting: [REC CHECK])
[USER6]	Sets the function to assign to the [USER6] button icon. (Factory setting: [AWB])
[USER7]	Sets the function to assign to the [USER7] button icon. (Factory setting: [AREA])
[USER8]	Sets the function to assign to the [USER8] button icon. (Factory setting: [FACE DETECT])
[USER9]	Sets the function to assign to the [USER9] button icon. (Factory setting: [ZEBRA])
[USER10]	Sets the function to assign to the [USER10] button icon. (Factory setting: [MENU])
[USER11]	Sets the function to assign to the [USER11] button icon. (Factory setting: [COUNTER])
[USER12]	Sets the function to assign to the [USER12] button icon. (Factory setting: [RESET])

## [SCENE FILE] menu

Sets the detailed image quality adjustment of the camera video.

This menu cannot be set when the thumbnail screen is displayed.

For the factory settings, refer to “Factory setting value of the scene file”. (→ 93)

## [FILE SELECT]

Selects the scene file (1 to 6).

You can save your favorite image settings in each scene file. Switch the scene file to suit the recording conditions.

The items that can be set are as follows.

- [F1:], [F2:FLUO], [F3:SPARK], [F4:STILL], [F5:CINE V], [F6:CINE D]

### 1 In the [SCENE FILE] menu → [FILE SELECT] → select the scene file you want to set.

- You can also select the scene file in the operation icon screen.

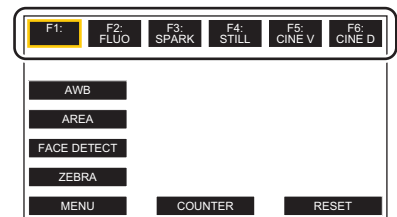

### 2 (When changing image settings)

#### Change the [SCENE FILE] menu settings.

You can save the following menu settings in the selected scene file (→ 69 to 73):

- |                             |                        |                      |
|-----------------------------|------------------------|----------------------|
| – [MASTER DTL]              | – [COLOR CORRECTION]   | – [DRS]              |
| – [DTL CORING]              | – [SKIN TONE DTL.]     | – [DRS EFFECT DEPTH] |
| – [V.DTL LEVEL]             | – [MASTER PED]         | – [NR CONTROL]       |
| – [RB GAIN CONTROL SETTING] | – [GAMMA MODE SEL]     | – [AE LEVEL]         |
| – [CHROMA LEVEL]            | – [BLACK GAMMA]        | – [AE LEVEL EFFECT]  |
| – [CHROMA PHASE]            | – [KNEE MODE]          |                      |
| – [MATRIX]                  | – [WHITE CLIP SETTING] |                      |

#### ■ Scene file settings at the time of purchase

F1:	Settings suited to standard recording
F2:FLUO	Settings suited to recording with consideration for fluorescent lighting (indoors, etc.)
F3:SPARK	Settings suited to recordings where there is a variation in resolution, color hue, and contrast
F4:STILL	You can apply a scene file with the picture tone of a digital still camera.
F5:CINE V	Settings suited to recordings made with an emphasis on contrast to provide a cinematic sensation
F6:CINE D	Settings suited to recordings made with an emphasis on the dynamic range to provide a cinematic sensation

#### NOTE

- The setting at the time of purchase is [F1:].
- The operation icons disappear when you touch the screen while the operation icons are being displayed or if no touch operations are performed for a while. To display again, touch and hold the screen for approximately 2 seconds.

**[NAME EDIT]**

Edits the name of the scene file selected in the scene file menu. (Maximum 8 characters)

- Refer to page 101 for setting procedures.

**[LOAD/SAVE/INITIALIZE]**

Loads/saves/initializes the setting values of the scene file assigned to the current scene file number (any one from 1 to 6).

[LOAD]	Selects and loads the scene file saved in the internal memory of the unit.
[SAVE]	Saves the current setting value as a scene file in the internal memory of the unit by specifying the title and the file number.
[INITIALIZE]	Initializes the selected scene files (1 to 6) to the factory settings.

- Refer to pages 100 to 101 for setting procedures.

**[MASTER DTL]**

Sets the level of the detail effect of the whole part.

The items that can be set are as follows.

- [-15]...[+15]

**[DTL CORING]**

Sets the level of signal (including noise) that does not activate the detail effect.

The items that can be set are as follows.

- [0]...[30]

**[V.DTL LEVEL]**

Sets the intensity of the detail level in the vertical direction.

The items that can be set are as follows.

- [-7]...[+7]

**[RB GAIN CONTROL SETTING]**

Adjust the color hue when white balance has been set in [Ach] or [Bch].

You can also decide whether to maintain the setting content when you have made white balance adjustments/black balance adjustments.

**[R GAIN AWB A]**

Set the Rch gain (strength of red) for white balance [Ach].

The items that can be set are as follows.

- [-30]...[+30]

**[B GAIN AWB A]**

Set the Bch gain (strength of blue) for white balance [Ach].

The items that can be set are as follows.

- [-30]...[+30]

**[R GAIN AWB B]**

Set the Rch gain (strength of red) for white balance [Bch].

The items that can be set are as follows.

- [-30]...[+30]

**[B GAIN AWB B]**

Set the Bch gain (strength of blue) for white balance [Bch].

The items that can be set are as follows.

- [-30]...[+30]

**[AWB A GAIN OFFSET]**

When the white balance has been automatically performed with [Ach], set the value of Rch gain and Bch gain.

[ON]	Keeps the values set in [R GAIN AWB A] and [B GAIN AWB A].
[OFF]	Sets the value of Rch gain and Bch gain to [0].

**[AWB B GAIN OFFSET]**

When the white balance has been automatically performed with [Bch], set the value of Rch gain and Bch gain.

[ON]	Keeps the values set in [R GAIN AWB B] and [B GAIN AWB B].
[OFF]	Sets the value of Rch gain and Bch gain to [0].

**[CHROMA LEVEL]**

Sets the chroma level of P<sub>R</sub> and P<sub>B</sub> signals.

The items that can be set are as follows.

- [-50]...[+50]

**[CHROMA PHASE]**

Finely adjusts the chroma phase of the P<sub>R</sub> signal and P<sub>B</sub> signal.

The items that can be set are as follows.

- [-31]...[+31]

**[MATRIX]**

Selects the matrix table to display the color for shooting.

[NORMAL1]	Displays the color suitable for shooting outdoors or under a halogen lamp.
[NORMAL2]	Displays more vivid color than [NORMAL1].
[FLUO.]	Displays the color suitable for shooting indoors under fluorescent light.
[CINELIKE]	Displays the color suitable for shooting cinematic video.
[STILL LIKE]	Expresses colors in a picture tone similar to that produced with a digital still camera.

**[COLOR CORRECTION]**

Sets the saturation and phase for colors. Each of the 16 divisions of color hue can be set individually.

**[R]**

[SAT]	Corrects red color saturation.
[PHASE]	Corrects the red hue.

The items that can be set are as follows.

- [-63]...[+63]

**[R-Mg]**

[SAT]	Corrects the color saturation between red and magenta.
[PHASE]	Corrects the hue between red and magenta.

The items that can be set are as follows.

- [-63]...[+63]

**[Mg]**

[SAT]	Corrects magenta color saturation.
[PHASE]	Corrects the magenta hue.

The items that can be set are as follows.

- [-63]...[+63]

**[Mg-Mg-B]**

[SAT]	Corrects the color saturation between magenta and the color which is intermediate between magenta and blue.
[PHASE]	Corrects the hue between magenta and the color which is intermediate between magenta and blue.

The items that can be set are as follows.

- [-63]...[+63]

**[Mg-B-B]**

[SAT]	Corrects the color saturation between blue and the color which is intermediate between magenta and blue.
[PHASE]	Corrects the hue between blue and the color which is intermediate between magenta and blue.

The items that can be set are as follows.

- [-63]...[+63]

**[B]**

[SAT]	Corrects blue color saturation.
[PHASE]	Corrects the blue hue.

The items that can be set are as follows.

- [-63]...[+63]

**[B-B-Cy]**

[SAT]	Corrects the color saturation between blue and the color which is intermediate between blue and cyan.
[PHASE]	Corrects the hue between blue and the color which is intermediate between blue and cyan.

The items that can be set are as follows.

- [-63]...[+63]

**[B-Cy-Cy]**

[SAT]	Corrects the color saturation between cyan and the color which is intermediate between blue and cyan.
[PHASE]	Corrects the hue between cyan and the color which is intermediate between blue and cyan.

The items that can be set are as follows.

- [-63]...[+63]

**[Cy]**

[SAT]	Corrects cyan color saturation.
[PHASE]	Corrects the cyan hue.

The items that can be set are as follows.

- [-63]...[+63]

**[Cy-G]**

[SAT]	Corrects the color saturation between cyan and green.
[PHASE]	Corrects the hue between cyan and green.

The items that can be set are as follows.

- [-63]...[+63]

**[G]**

[SAT]	Corrects green color saturation.
[PHASE]	Corrects the green hue.

The items that can be set are as follows.

- [-63]...[+63]

**[G-G-Y!]**

[SAT]	Corrects the color saturation between green and the color which is intermediate between green and yellow.
[PHASE]	Corrects the hue between green and the color which is intermediate between green and yellow.

The items that can be set are as follows.

- [-63]...[+63]

**[G-YI-Y!]**

[SAT]	Corrects the color saturation between yellow and the color which is intermediate between green and yellow.
[PHASE]	Corrects the hue between yellow and the color which is intermediate between green and yellow.

The items that can be set are as follows.

- [-63]...[+63]

**[Y!]**

[SAT]	Corrects yellow color saturation.
[PHASE]	Corrects the yellow hue.

The items that can be set are as follows.

- [-63]...[+63]

**[YI-YI-R]**

[SAT]	Corrects the color saturation between yellow and the color which is intermediate between yellow and red.
[PHASE]	Corrects the hue between yellow and the color which is intermediate between yellow and red.

The items that can be set are as follows.

- [-63]...[+63]

**[YI-R-R]**

[SAT]	Corrects the color saturation between red and the color which is intermediate between yellow and red.
[PHASE]	Corrects the hue between red and the color which is intermediate between yellow and red.

The items that can be set are as follows.

- [-63]...[+63]

**[SKIN TONE DTL.]**

The skin of human subjects can be made to appear smoother when recorded.

The items that can be set are as follows.

- [ON], [OFF]

**NOTE**

- If the background or anything else in the scene has colors similar to the skin color, they will also be smoothed.
- If the brightness is insufficient, the effect may not be clear.
- If you record a person in the distance, the face may not be recorded clearly. In this case, set [SKIN TONE DTL.] to [OFF] or zoom in on the face (close-up) to record.

**[MASTER PED]**

Sets the master pedestal.

The items that can be set are as follows.

- [-70]...[+70]

**[GAMMA MODE SEL]**

Selects the gamma mode.

[HD]	Sets the gamma characteristics for HD (High Definition).
[SD]	Increases gain in darker areas more than HD gamma.
[FILMLIKE1]	Sets the characteristics that reproduce more highlight areas compared to HD gamma.
[FILMLIKE2]	Sets the characteristics that reproduce more highlight areas compared to [FILMLIKE1].
[FILMLIKE3]	Sets the characteristics that reproduce more highlight areas compared to [FILMLIKE2].
[CINE-LIKE D]	Sets gamma characteristics to produce images that provide a cinematic sensation.
[CINE-LIKE V]	Sets gamma characteristics to produce images with an emphasis on contrast to provide a cinematic sensation.
[STILL LIKE]	Sets the gamma characteristics for a digital still camera image tone.

**[BLACK GAMMA]**

Sets the gamma curves of dark areas.

[-4]...[-1]	Compresses dark parts.
[0]	Standard state
[+1]...[+4]	Expands dark areas.

**[KNEE MODE]**

To avoid overexposure, select the compression level of the high intensity video signals received through the image sensor.

[AUTO]	Sets up automatically depending on the signal from the image sensor.
[LOW]	Low setting (Compression starts at approx. 80%.)
[MID]	Medium setting (Compression starts at approx. 90%.)
[HIGH]	High setting (Compression starts at approx. 100%.)
[OFF]	Disables the Knee function.

**[WHITE CLIP SETTING]**

Sets so that the brightest parts of the video signal cannot exceed a certain level.

**[WHITE CLIP]**

Switches the white clip function [ON]/[OFF].The [WHITE CLIP LEVEL] setting value is enabled when [ON].

The items that can be set are as follows.

- [ON], [OFF]

**[WHITE CLIP LEVEL]**

Sets the white clip level.

The items that can be set are as follows.

- [90%]...[109%]

**[DRS]**

Switches enable/disable of the dynamic range stretcher function.

If functions are assigned to the USER buttons, [ON]/[OFF] can be switched using the USER button operations.

The items that can be set are as follows.

- [ON], [OFF]



**[DRS EFFECT DEPTH]**

Sets the compression level of the high luminosity areas of the dynamic range stretcher function.

By compressing the video signal levels of the high luminosity areas that are blown out in normal shooting, the dynamic range can be expanded.

The items that can be set are as follows.

- [1]...[3]

**NOTE**

- As the number increases, the compression level of high luminosity areas increases, and there will be more noise in dark areas.

**[NR CONTROL]**

You can adjust the effect of noise reduction and afterimages by changing the noise reduction settings.

[-7]...[-1]	Weakens the effect of noise reduction, reducing afterimages. There will tend to be more noise.
[0]	Standard state
[+1]...[+7]	Strengthens the effect of noise reduction, reducing noise. However, this may result in an increase in afterimages.

**[AE LEVEL]**

Switches enable/disable of the AE level function.

If functions are assigned to the USER buttons, [ON]/[OFF] can be switched using the USER button operations.

The items that can be set are as follows.

- [ON], [OFF]

**NOTE**

- In the following cases, this cannot be set.
  - When all of iris, gain, and shutter speed are set to manual in the manual mode
  - When IR recording is enabled

**[AE LEVEL EFFECT]**

When AE level is enabled, you can set the exposure compensation value.

Set to the "+" direction to brighten and set to the "-" direction to darken.

The items that can be set are as follows.

- [-2.0EV]...[+2.0EV]

**NOTE**

- In the following cases, this cannot be set.
  - When all of iris, gain, and shutter speed are set to manual in the manual mode
  - When IR recording is enabled

**[AUDIO] menu**

Sets the input/output function of audio.

**[HANDLE UNIT INPUT SETTING]**

This can be set when the handle unit ( **X2000** supplied, **X1500** optional) is attached to the unit.

**[INPUT1 MIC LEVEL]**

Sets the input level of the external microphone connected to the <INPUT 1> terminal. Enabled when the external microphone is connected and the <INPUT1> switch is set to <MIC> or <+48V>.

The items that can be set are as follows.

- [-40dB], [-50dB], [-60dB]

(Factory setting: [-50dB])

**[INPUT2 MIC LEVEL]**

Sets the input level of the external microphone connected to the <INPUT 2> terminal. Enabled when the external microphone is connected and the <INPUT2> switch is set to <MIC> or <+48V>.

The items that can be set are as follows.

- [-40dB], [-50dB], [-60dB]

(Factory setting: [-50dB])

**[INPUT1 LINE LEVEL]**

Sets the audio input level of the audio device connected to the <INPUT 1> terminal. Enabled when the audio device is connected and the <INPUT1> switch is set to <LINE>.

The items that can be set are as follows.

- [4dB], [0dB]

(Factory setting: [0dB])

**[INPUT2 LINE LEVEL]**

Sets the audio input level of the audio device connected to the <INPUT 2> terminal. Enabled when the audio device is connected and the <INPUT2> switch is set to <LINE>.

The items that can be set are as follows.

- [4dB], [0dB]
- (Factory setting: [0dB])

**[MIC SETTING]**

This can be set when the handle unit ( **X2000** supplied, **X1500** optional) has not been attached to the unit.

**[CH1 LEVEL]**

Sets if the recording level adjustment method for audio channel 1 is to be automatic or manual.

The items that can be set are as follows.

- [AUTO], [MANUAL]
- (Factory setting: [AUTO])

**[CH2 LEVEL]**

Sets if the recording level adjustment method for audio channel 2 is to be automatic or manual.

The items that can be set are as follows.

- [AUTO], [MANUAL]
- (Factory setting: [AUTO])

**[CH1 LEVEL CONTROL]**

The recording level can be manually adjusted when [CH1 LEVEL] adjusting the recording level of the audio channel 1 is set to [MANUAL].

The items that can be set are as follows.

- [MUTE], [-30dB]...[+12dB]
- (Factory setting: [0dB])

**[CH2 LEVEL CONTROL]**

The recording level can be manually adjusted when [CH2 LEVEL] adjusting the recording level of the audio channel 2 is set to [MANUAL].

The items that can be set are as follows.

- [MUTE], [-30dB]...[+12dB]
- (Factory setting: [0dB])

**[INPUT SETTINGS]****[CH1 MIC LOWCUT]**

Switches enable/disable of the lowcut filter for audio channel 1.

The items that can be set are as follows.

- [ON], [OFF]
- (Factory setting: [OFF])

**[CH2 MIC LOWCUT]**

Switches enable/disable of the lowcut filter for audio channel 2.

The items that can be set are as follows.

- [ON], [OFF]
- (Factory setting: [OFF])

**[CH1 LIMITER]**

Switches enable/disable of the limiter when the method to adjust the audio input level for audio channel 1 is manual.

The items that can be set are as follows.

- [ON], [OFF]
- (Factory setting: [OFF])

** NOTE**

- In the following case, [CH1 LIMITER] is fixed to [ON]:
  - When [CH1 LEVEL] is set to [AUTO]
  - When the <CH1> switch is set to <AUTO>

**[CH2 LIMITER]**

Switches enable/disable of the limiter when the method to adjust the audio input level for audio channel 2 is manual.

The items that can be set are as follows.

- [ON], [OFF]
- (Factory setting: [OFF])

** NOTE**

- In the following case, [CH2 LIMITER] is fixed to [ON]:
  - When [CH2 LEVEL] is set to [AUTO]
  - When the <CH2> switch is set to <AUTO>

### [MIC LIMITER LINK]

Sets whether to make the limiter work on the other audio channel when the limiter works in either audio channel 1 or audio channel 2.

The items that can be set are as follows.

- [ON], [OFF]
- (Factory setting: [OFF])

#### NOTE

- In the following case, [MIC LIMITER LINK] is fixed to [OFF]:
  - [CH1 LIMITER] or [CH2 LIMITER] is set to [OFF]

### [OUTPUT SETTINGS]

#### [AUDIO OUT]

Sets the audio channel and the format to output from the headphone terminal, and the built-in speaker.

[CH1]	Outputs the signal for audio channel 1 as monaural.
[CH2]	Outputs the signal for audio channel 2 as monaural.
[CH1/2 STEREO]	Outputs the signals of the audio channel 1 and the audio channel 2 as stereo. Outputs as monaural from the built-in speaker.
[CH1/2 MIX]	Mixes the signals of the audio channel 1 and the audio channel 2 and outputs as monaural.

(Factory setting: [CH1/2 STEREO])

### [ALARM]

Sets whether to have an alarm sound.

The alarm is output from the speaker of this unit or the headphones. It is not output to external output destinations.

#### [BATTERY END]

Sets whether to sound the alarm when the remaining battery level is exhausted.

The items that can be set are as follows.

- [HIGH], [LOW], [OFF]
- (Factory setting: [OFF])

#### [MEDIA END]

Sets whether to sound the alarm when the remaining recording capacity of the memory card is exhausted.

The items that can be set are as follows.

- [HIGH], [LOW], [OFF]
- (Factory setting: [OFF])

#### [WARNING]

Sets whether to sound the alarm when a system error or warning occurs.

The items that can be set are as follows.

- [HIGH], [LOW], [OFF]
- (Factory setting: [OFF])

### [VIDEO OUT/LCD/VF] menu

Configures the settings for the external output, the information to display in the LCD monitor or viewfinder and the output format.



#### [VIDEO OUT SEL]

Switches the output destination for images and audio.

[SDI]	Outputs from the <SDI OUT> terminal.
[HDMI]	Outputs from the <HDMI> terminal.

(Factory setting: [HDMI])



#### [SDI OUT]

- Set the [VIDEO OUT/LCD/VF] menu → [VIDEO OUT SEL] to [SDI].

#### [OUT FORMAT]

Selects the signal to output from the <SDI OUT> terminal. The items that can be selected differ depending on the [SYSTEM] menu → [FREQUENCY]/[FILE FORMAT]/[REC FORMAT] setting.

[1920×1080p]	Outputs in 1920×1080p.
[1920×1080i]	Outputs in 1920×1080i.
[1920×1080PsF]	Outputs in 1920×1080PsF.
[1280×720p]	Outputs in 1280×720p.

(Factory setting: [1920×1080i])

**NOTE**

- For the combinations that can be set, refer to "Format that can be output from the <SDI OUT> terminal [X2000]". ( → 157)

**[SDI AUDIO GAIN CHG]**

Adjusts the gain for the audio signal output from the <SDI OUT> terminal.

The items that can be set are as follows.

- [0dB], [-6dB], [-8dB]

(Factory setting: [-8dB])

**[SDI REC REMOTE]**

Sets if the recording operation against the external equipment connected to the <SDI OUT> terminal (such as recorder) is to be controlled or not.

[ON]	Controls the recording operation of the external equipment.
[OFF]	Does not control the recording operation of the external equipment.

(Factory setting: [OFF])

**NOTE**

- This cannot be set when the [RECORDING] menu → [REC FUNCTION] → [REC MODE] is set to [INTERVAL].
- The AUTO REC signal is compatible with TYPE3 when remotely recording with SDI.

**[SDI OUT CHAR]**

Sets whether to superimpose the character to the output from the <SDI OUT> terminal.

[ON]	Superimposes.
[OFF]	Does not superimpose.

(Factory setting: [OFF])

**[SDI OUT ZEBRA]**

Sets whether to superimpose the zebra signal to the output from the <SDI OUT> terminal. The settings of the zebra signal follow the zebra signal settings in the [VIDEO OUT/LCD/VF] menu → [EI ASSIST].

[ON]	Superimposes.
[OFF]	Does not superimpose.

(Factory setting: [OFF])

**[HDMI OUT]**

- Set the [VIDEO OUT/LCD/VF] menu → [VIDEO OUT SEL] to [HDMI].

**[OUT FORMAT]**

Selects the signal to output from the <HDMI> terminal. The items that can be selected differ depending on the [SYSTEM] menu → [FREQUENCY]/[FILE FORMAT]/[REC FORMAT] setting.

[3840×2160p]	Outputs in 3840×2160p (4:2:2/10 bit).
[3840×2160p(420/8bit)]	Outputs in 3840×2160p (4:2:0/8 bit).
[1920×1080p]	Outputs in 1920×1080p.
[1920×1080i]	Outputs in 1920×1080i.
[1280×720p]	Outputs in 1280×720p.
[720×480p]	Outputs in 720×480p.
[720×576p]	Outputs in 720×576p.

(Factory setting: [1920×1080p])

**NOTE**

- For the combinations that can be set, refer to "Format that can be output from the <HDMI> terminal". ( → 158)

**[HDMI TC OUT]**

Sets if the time code information is output or not in the output from the <HDMI> terminal.

The items that can be set are as follows.

- [ON], [OFF]

(Factory setting: [OFF])

**[HDMI REC REMOTE]**

Sets if the recording operation against the external equipment connected to the <HDMI> terminal (such as recorder) is to be controlled or not. This can be set when [HDMI TC OUT] in [HDMI OUT] is enabled.

[ON]	Controls the recording operation of the external equipment.
[OFF]	Does not control the recording operation of the external equipment.

(Factory setting: [OFF])

**NOTE**

- This cannot be set when the [RECORDING] menu → [REC FUNCTION] → [REC MODE] is set to [INTERVAL].

**[HDMI OUT CHAR]**

Sets whether to superimpose the character to the output from the <HDMI> terminal.

[ON]	Superimposes.
[OFF]	Does not superimpose.

(Factory setting: [OFF])

**[HDMI OUT ZEBRA]**

Sets whether to superimpose the zebra signal to the output from the <HDMI> terminal. The settings of the zebra signal follow the zebra signal settings in the [VIDEO OUT/LCD/VF] menu → [EI ASSIST].

[ON]	Superimposes.
[OFF]	Does not superimpose.

(Factory setting: [OFF])

**[LCD]**

- These settings will not affect the images actually recorded.

**[BRIGHTNESS]**

Adjusts the brightness of the LCD monitor.

The items that can be set are as follows.

- [-15]...[+15]

(Factory setting: [0])

**[COLOR LEVEL]**

Adjusts the color level of the LCD monitor.

The items that can be set are as follows.

- [-15]...[+15]

(Factory setting: [0])

**[CONTRAST]**

Adjusts the contrast of the LCD monitor.

The items that can be set are as follows.

- [-15]...[+15]

(Factory setting: [0])

**[BACK LIGHT]**

Adjusts the brightness of the LCD monitor backlight. [0] is the standard brightness.

The items that can be set are as follows.

- [-1], [0], [1], [2]

(Factory setting: [0])

**[RED TINT]**

Finely adjusts the strength of red on the LCD monitor.

The items that can be set are as follows.

- [-10]...[+10]

(Factory setting: [0])

**[BLUE TINT]**

Finely adjusts the strength of blue on the LCD monitor.

The items that can be set are as follows.

- [-10]...[+10]

(Factory setting: [0])

**[SELF SHOOT]**

Sets the display of the LCD monitor when mirror shooting is performed.

[NORMAL]	Does not invert the left and right sides.
[MIRROR]	Inverts the left and right sides.

(Factory setting: [MIRROR])

**[VF]**

- These settings will not affect the images actually recorded.

**[BRIGHTNESS]**

Adjusts the brightness of the viewfinder.

The items that can be set are as follows.

- [-15]...[+15]

(Factory setting: [0])

**[COLOR LEVEL]**

Adjusts the color level of the viewfinder.

The items that can be set are as follows.

- [-15]...[+15]

(Factory setting: [0])

**[CONTRAST]**

Adjusts the contrast of the viewfinder.

The items that can be set are as follows.

- [-15]...[+15]

(Factory setting: [0])

**[RED TINT]**

Finely adjusts the strength of red on the viewfinder.

The items that can be set are as follows.

- [-10]...[+10]

(Factory setting: [0])

**[BLUE TINT]**

Finely adjusts the strength of blue on the viewfinder.

The items that can be set are as follows.

- [-10]...[+10]

(Factory setting: [0])

**[VF COLOR]**

Sets whether to display video in the viewfinder in color or black and white.

[ON]	Displays in color.
[OFF]	Displays in black and white.

(Factory setting: [ON])

**[INDICATOR]**

Selects the indicator to display in the output image.

**[FULL AUTO]**

Switches display/hide of the status when the <AUTO/MANU> switch is at <AUTO>.

The items that can be set are as follows.

- [ON], [OFF]

(Factory setting: [ON])

**[SLOT1/2 STATUS]**

Switches display/hide of the status of the card slot and remaining recording capacity.

The items that can be set are as follows.

- [ON], [OFF]

(Factory setting: [ON])

**[2 SLOTS FUNC.]**

Switches display/hide of the setting in the [RECORDING] menu → [2 SLOTS FUNC.].

The items that can be set are as follows.

- [ON], [OFF]

(Factory setting: [ON])

**[STREAMING]**

Switches display/hide of the streaming status.

The items that can be set are as follows.

- [ON], [OFF]

(Factory setting: [ON])

**[NETWORK]**

Switches display/hide of the wireless LAN connection status.

The items that can be set are as follows.

- [ON], [OFF]

(Factory setting: [ON])

#### **[BATTERY REMAIN]**

Switches display/hide of the power status.

The items that can be set are as follows.

- [ON], [OFF]
- (Factory setting: [ON])

#### **[REC FORMAT]**

Switches display/hide of the recording format settings.

The items that can be set are as follows.

- [ON], [OFF]
- (Factory setting: [ON])

#### **[FRAME RATE]**

Switches display/hide of the frame rate for super slow recording.

The items that can be set are as follows.

- [ON], [OFF]
- (Factory setting: [ON])

#### **[CLIP NAME]**

Switches display/hide of the clip file name to be recorded. Up to 8 characters from the beginning of the file name are displayed.

The items that can be set are as follows.

- [ON], [OFF]
- (Factory setting: [ON])

#### **[REC REMOTE]**

Switches display/hide of the control status of the recording start and recording stop on the external equipment connected to the <SDI OUT> terminal\* and the <HDMI> terminal.

\* Available for use when using **X2000**.

The items that can be set are as follows.

- [ON], [OFF]
- (Factory setting: [ON])

#### **[REC MODE]**

Switches display/hide of the status of interval recording.

The items that can be set are as follows.

- [ON], [OFF]
- (Factory setting: [ON])

#### **[FBC]**

Switches whether to display when the flash band compensation function is activated.

The items that can be set are as follows.

- [ON], [OFF]
- (Factory setting: [ON])

#### **[DRS]**

Switches whether to display when the dynamic range stretcher function is operating.

The items that can be set are as follows.

- [ON], [OFF]
- (Factory setting: [ON])

#### **[O.I.S.]**

Switches whether to display when the optical image stabilizer function is operating.

The items that can be set are as follows.

- [ON], [OFF]
- (Factory setting: [ON])

#### **[SCENE FILE]**

Switches display/hide of the scene file name.

The items that can be set are as follows.

- [ON], [OFF]
- (Factory setting: [ON])

#### **[AREA/FACE]**

Switches whether to display when the area mode function or the face detection/tracking AE&AF function is operating.

The items that can be set are as follows.

- [ON], [OFF]
- (Factory setting: [ON])

#### **[AUDIO LEVEL METER]**

Switches display/hide of the audio level meter.

The items that can be set are as follows.

- [ON], [OFF]
- (Factory setting: [ON])

**[GAIN]**

Switches display/hide of the gain value.

The items that can be set are as follows.

- [ON], [OFF]

(Factory setting: [ON])

**[ND FILTER]**

Switches display/hide of the ND filter transmittance rate.

The items that can be set are as follows.

- [ON], [OFF]

(Factory setting: [ON])

**[SHUTTER]**

Switches display/hide of the shutter speed.

The items that can be set are as follows.

- [ON], [OFF]

(Factory setting: [ON])

**[IRIS]**

Switches display/hide of the iris value and the auto iris control status.

The items that can be set are as follows.

- [ON], [OFF]

(Factory setting: [ON])

**[AE LEVEL]**

Switches display/hide of the AE level.

The items that can be set are as follows.

- [ON], [OFF]

(Factory setting: [ON])

**[ZOOM/FOCUS]**

Switches the units of zoom and focus values.

[NUMBER]	Displays a position value for the zoom from [00] to [99] and focus from [00] to [99].
[mm/feet]	Displays the zoom in units of millimeters and the focus in units of feet.
[mm/m]	Displays the zoom in units of millimeters and the focus in units of meters.
[OFF]	Does not display either the zoom or focus.

(Factory setting: [NUMBER])

**[WHITE BALANCE]**

Switches display/hide of the color temperature.

The items that can be set are as follows.

- [ON], [OFF]

(Factory setting: [ON])

**[FACE DETECTION]**

Switches whether to display the face detection frame when the face detection/tracking AE&AF function is operating.

[ALL]	Displays all face detection frames.
[MAIN FACE]	Displays only the main face frame (orange frame).
[OFF]	Face detection frames and tracking frames are not displayed.

(Factory setting: [ALL])

**[DATE/TIME]**

Switches display/hide of the date and time.

The display for the year, month, and day follows the [DATE FORMAT] setting.

The date and time are not displayed when the time stamp function is enabled.

[OFF]	Does not display the date and time.
[DATE]	Displays only the date.
[TIME]	Displays only the time.
[DATE&TIME]	Displays the date and time.

(Factory setting: [OFF])

**[MULTI MANUAL]**

Switches display/hide of the multi manual function.

The items that can be set are as follows.

- [ON], [OFF]

(Factory setting: [ON])



**[D.ZOOM]**

Switches display/hide of digital zoom ratio.

The items that can be set are as follows.

- [ON], [OFF]
- (Factory setting: [ON])

**[IR REC]**

Switches display/hide of the settings in the [CAMERA] menu → [SW MODE] → [IR REC].

The items that can be set are as follows.

- [ON], [OFF]
- (Factory setting: [ON])

**[PLAYBACK STATUS]**

Switches display/hide of the playback status.

The items that can be set are as follows.

- [ON], [OFF]
- (Factory setting: [ON])

**[MARKER]**

**[CENTER MARKER]**

Switches the type of center marker.

[1]	+ (large)
[2]	Open center (large)
[3]	+ (small)
[4]	Open center (small)
[OFF]	Does not display.

(Factory setting: [1])

**[SAFETY MARKER]**

Selects the type of frame for the safety zone marker.

[1]	Box
[2]	Corners
[OFF]	Does not display.

(Factory setting: [2])

**[FRAME MARKER]**

Sets the aspect ratio of the frame marker. The frame marker is not displayed when [OFF] is selected.

The items that can be set are as follows.

- [4:3], [13:9], [14:9], [1.85:1], [2.35:1], [OFF]
- (Factory setting: [OFF])

**[FOCUS ASSIST]**

**[FOCUS ASSIST SW]**

Sets how focus assist is set when the [FOCUS ASSIST] in the USER button is set.

[EXPAND]	Sets the enlarged display.
[PEAKING]	Sets the peaking display.
[EXPAND&PEAKING]	Sets both [EXPAND] and [PEAKING].

(Factory setting: [EXPAND&PEAKING])

**[EXPAND MODE]**

Sets the enlargement display function mode.

[10SEC]	Disables the enlarged display function after 10 seconds have elapsed.
[HOLD]	Enables the enlarged display function until either the USER button assigned to [FOCUS ASSIST] is pressed again or the USER button icon is touched again.
[UNTIL REC]	Enables the enlarged display function until performing recording operation.

(Factory setting: [10SEC])

**[EXPAND VALUE]**

Adjusts the enlargement factor of the enlarged display function.

The items that can be set are as follows.

- [×2], [×3], [×4]
- (Factory setting: [×2])

**[PEAKING LEVEL]**

Sets the intensity of the peaking display.

The items that can be set are as follows.

- [LOW], [MID], [HIGH]

(Factory setting: [MID])

**[PEAKING COLOR]**

Sets the color of the peaking display.

The items that can be set are as follows.

- [RED], [GREEN], [WHITE]

(Factory setting: [RED])

**[DETAIL]**

Sets the intensity of the contour for the video to make it easier to focus.

The items that can be set are as follows.

- [ON], [OFF]

(Factory setting: [OFF])

**[DETAIL LEVEL]**

Sets the intensity of the contours.

The items that can be set are as follows.

- [-3]...[+3]

(Factory setting: [0])

**[DETAIL FREQ.]**

Adjusts the frequency of the contour highlights.

The items that can be set are as follows.

- [HIGH], [LOW]

(Factory setting: [LOW])

**[EI ASSIST]****[ZEBRA]**

Sets whether to superimpose the zebra signal to the output.

[MOMENT]	Press the USER button to which [ZEBRA] is assigned or touch the USER button icon to superimpose the zebra signal for approximately 5 seconds.
[ON]	Always superimposes the zebra signal. Press the USER button to which [ZEBRA] is assigned in the [ON] settings or touch the USER button icon to set to [OFF].
[OFF]	Does not superimpose the zebra signal. Press the USER button to which [ZEBRA] is assigned in the [OFF] settings or touch the USER button icon to set to [ON].

(Factory setting: [OFF])

**[ZEBRA1 DETECT]**

Sets the detection level of zebra pattern 1.

The items that can be set are as follows.

- [50%]...[105%]

(Factory setting: [80%])

**[ZEBRA2 DETECT]**

Sets the detection level of zebra pattern 2.

The items that can be set are as follows.

- [50%]...[105%]

(Factory setting: [100%])

**[ZEBRA2]**

Switches enable/disable of zebra pattern 2.

The items that can be set are as follows.

- [ON], [OFF]

(Factory setting: [OFF])

**[WFM MODE]**

Sets the display of the waveform monitor. Displaying of the waveform and the vector can be switched.

[WAVE]	Displays the waveform.
[VECTOR]	Displays the vector.
[WAVE/VECTOR]	Displays the waveform and the vector. Each time you either press the USER button assigned to [WFM] or touch the USER button icon, the display switches in the order waveform, vector, no display.

(Factory setting: [WAVE])

**[WFM TRANSPARENCE]**

Sets the transmittance of the waveform monitor.

The items that can be set are as follows.

- [0%], [25%], [50%]

(Factory setting: [25%])

**[LEVEL GAUGE]****[LEVEL GAUGE]**

Switches display/hide of the level gauge.

The items that can be set are as follows.

- [ON], [OFF]

(Factory setting: [ON])

**[LEVEL GAUGE RESET]**

Sets the horizontal and vertical reference value set by [LEVEL GAUGE SET] in the USER button to the factory setting.

The items that can be selected are as follows.

- [YES], [NO]

**[RECORDING] menu**

Sets the various items in the recording function.

**[FORMAT MEDIA]**

Formats the memory card in the specified card slot.

All data will be deleted when the card is formatted. Save any important data to a computer, etc. (→ 170)

The items that can be selected are as follows.

- [SLOT1], [SLOT2]

**[CLIP NAME]****[CAM INDEX]**

Sets the CAM INDEX used for recorded MOV format/MP4 format file names.

Set one upper case alphabetical character. This is used as a value to be stored in the volume label of the memory card.

The items that can be set are as follows.

- [A]...[Z]

(Factory setting: [A])

**[NEXT CARD COUNT]**

Sets the CARD COUNT used for recorded MOV format/MP4 format file names.

In the following cases, the setting value in [NEXT CARD COUNT] is stored in the volume label of the memory card together with the [CAM INDEX] setting value as CARD COUNT. Also, the setting value will increase one after storing. ([001] returns after [999])

- When formatted the memory card
- When recorded to the memory card where CARD COUNT is not stored in the volume label

The items that can be set are as follows.

- [001]...[999]

(Factory setting: [001])

**[2 SLOTS FUNC.]**

Sets the recording function that uses 2 memory cards.

[OFF]	Does not set.
[RELAY REC]	Sets to the relay recording. (→ 129)
[SIMUL REC]	Sets to the simultaneous recording. (→ 130)
[BACKGR REC]	Sets to the background recording. (→ 131)

(Factory setting: [RELAY REC])

**[PRE REC]**

Sets whether to perform pre-recording. (→ 129)

The items that can be selected are as follows.

- [ON], [OFF]

(Factory setting: [OFF])

**[REC FUNCTION]****[REC MODE]**

Selects the recording mode.

[NORMAL]	Performs the standard recording.
[INTERVAL]	Performs the interval recording. (→ 132)

(Factory setting: [NORMAL])

**[INTERVAL TIME]**

Sets the interval duration for interval recording.

The items that can be set are as follows.

- [1s], [2s], [5s], [10s], [30s], [1min], [5min], [10min]

(Factory setting: [5min])

**[TC/UB]****[TC PRESET]**

Sets the default value of the time code to record.

Hour	[00]...[23]
Minute	[00]...[59]
Second	[00]...[59]
Frame	[00]...[23] (when [23.98p]) [00]...[24] (when [50.00i], [50.00p], or [25.00p] is set) [00]...[29] (when [59.94i], [59.94p], or [29.97p] is set)

(Factory setting: [00]) (each item)

- “h” is an abbreviation for hour, “m” for minute, “s” for second and “f” for frame.

**[UB PRESET]**

Sets user bits.

Enabled only when [USER] is selected in [UB MODE] of [TC/UB].

Each digit can be set in following range.

- [00]...[FF]

(Factory setting: [00])

**[FREE/REC RUN]**

Sets how the time code generator advances.

[FREE RUN]	Advances regardless of the operation mode.
[REC RUN]	Advances only while recording.

(Factory setting: [REC RUN])

**NOTE**

- The setting is fixed to [REC RUN] when the [SYSTEM] menu → [SUPER SLOW] → [ON] is set.
- The setting is fixed to [FREE RUN] when the [RECORDING] menu → [PRE REC] → [ON] is set.
- The setting is fixed to [FREE RUN] when the [RECORDING] menu → [2 SLOTS FUNC.] → [BACKGR REC] is set.
- The setting is fixed to [REC RUN] when the [RECORDING] menu → [REC FUNCTION] → [REC MODE] → [INTERVAL] is set.

**[DF/NDF]**

Sets the count method for the time code generator.

Enabled only when the frame rate of the [SYSTEM] menu → [REC FORMAT] is set to 59.94i/59.94p/29.97p.

[DF]	Uses the drop frame mode.
[NDF]	Uses the non-drop frame mode.

(Factory setting: [DF])

**NOTE**

- The setting is fixed to [NDF] when the [RECORDING] menu → [REC FUNCTION] → [REC MODE] → [INTERVAL] is set.

**[UB MODE]**

Selects the user bits mode. User bits information is recorded in the clip.

[FRAME RATE]	Selects the image information (such as frame rate) of the camera.
[USER]	Selects the user bits set in [UB PRESET].
[TIME]	Selects the local time. (hh, mm, ss)
[DATE]	Selects the local date and time. (YY, MM, DD, hh)
[TC]	Records the time code value as user bits.
[CLIP NAME]	Records the value that CAM INDEX (one character) and CARD COUNT (3-digit number) both converted to ASCII character code. Only enabled when the [SYSTEM] menu → [FILE FORMAT] → [MOV] or [MP4] is set.

(Factory setting: [USER])

**[REC COUNTER]**

Sets operation of the counter for recording.

[TOTAL]	The count continues cumulatively until either you press the USER button assigned to [RESET] or touch the USER button icon.
[CLIP]	Clears the counter value at the start of recording and counts the time for each recording.

(Factory setting: [TOTAL])

**[TIME STAMP]**

Selects whether to superimpose the date and time on videos that are shot. The display for the year, month, and day follows the [DATE FORMAT] setting.

[OFF]	Does not superimpose the date and time.
[DATE]	Superimposes only the date.
[TIME]	Superimposes only the time.
[DATE&TIME]	Superimposes the date and time.

(Factory setting: [OFF])

**[NETWORK] menu**

Sets the setting regarding the network function.

**[DEVICE SEL]**

Select the device that connects external equipment (computer, etc.) to the unit.  
The unit may restart when the setting is changed.

[WLAN]	Connects via a wireless LAN.
[OFF]	Does not connect.

(Factory setting: [OFF])

**[NETWORK FUNC]**

Selects the network function of the unit.

[STREAMING]	Enables the streaming function.
[OFF]	Does not use the network function.

(Factory setting: [OFF])

**[IP REMOTE]**

Perform settings for the IP remote (remote operation by the HC ROP app).

**[ENABLE/DISABLE]**

Sets whether to enable the IP remote function.

The items that can be set are as follows.

- [ENABLE], [DISABLE]
- (Factory setting: [DISABLE])

**[USER ACCOUNT]**

Registers a new user account to use for authentication in the network function of the unit. (Maximum of 10 accounts)

The character limit of the user account name and password is as follows.

- User account name: Maximum of 31 characters
- Password: Between 8 to 15 characters

**[ACCOUNT LIST]**

Displays a list of registered users.

Furthermore, when you select a user, a message appears asking you to confirm if you want to delete a registered user.

**[STREAMING]**

Performs the settings for the streaming function.

**[STREAMING FORMAT]**

Specifies the streaming format.

The items that can be set are as follows.

[FILE FORMAT]	[REC FORMAT]	Items that can be set
[MOV], [MP4], [AVCHD]	1080-59.94p	[1920×1080-60fps 24M], [1920×1080-60fps 20M], [1920×1080-60fps 16M], [1280×720-60fps 14M], [1280×720-60fps 8M], [1280×720-60fps 3M], [640×360-30fps 4M], [640×360-30fps 1.5M], [640×360-30fps 0.7M], [320×180-30fps 4M], [320×180-30fps 1.5M], [320×180-30fps 0.5M] ● Factory setting: [640×360-30fps 0.7M]
	1080-50.00p	[1920×1080-50fps 24M], [1920×1080-50fps 20M], [1920×1080-50fps 16M], [1280×720-50fps 14M], [1280×720-50fps 8M], [1280×720-50fps 3M], [640×360-25fps 4M], [640×360-25fps 1.5M], [640×360-25fps 0.7M], [320×180-25fps 4M], [320×180-25fps 1.5M], [320×180-25fps 0.5M] ● Factory setting: [640×360-25fps 0.7M]
[MOV], [AVCHD]	([MOV]) 1080-59.94i or 1080-29.97p ([AVCHD]) 1080-59.94i	[1920×1080-30fps 14M], [1920×1080-30fps 6M], [1920×1080-30fps 1M], [1280×720-30fps 8M], [1280×720-30fps 2M], [1280×720-30fps 1M], [640×360-30fps 4M], [640×360-30fps 1.5M], [640×360-30fps 0.7M], [320×180-30fps 4M], [320×180-30fps 1.5M], [320×180-30fps 0.5M] ● Factory setting: [640×360-30fps 0.7M]
	([MOV]) 1080-50.00i or 1080-25.00p ([AVCHD]) 1080-50.00i	[1920×1080-25fps 14M], [1920×1080-25fps 6M], [1920×1080-25fps 1M], [1280×720-25fps 8M], [1280×720-25fps 2M], [1280×720-25fps 1M], [640×360-25fps 4M], [640×360-25fps 1.5M], [640×360-25fps 0.7M], [320×180-25fps 4M], [320×180-25fps 1.5M], [320×180-25fps 0.5M] ● Factory setting: [640×360-25fps 0.7M]
[MOV], [MP4], [AVCHD]	1080-23.98p	[1920×1080-24fps 14M], [1920×1080-24fps 6M], [1920×1080-24fps 1M] ● Factory setting: [1920×1080-24fps 1M]
[AVCHD]	720-59.94p	[1280×720-60fps 14M], [1280×720-60fps 8M], [1280×720-60fps 3M], [640×360-30fps 4M], [640×360-30fps 1.5M], [640×360-30fps 0.7M], [320×180-30fps 4M], [320×180-30fps 1.5M], [320×180-30fps 0.5M] ● Factory setting: [640×360-30fps 0.7M]
	720-50.00p	[1280×720-50fps 14M], [1280×720-50fps 8M], [1280×720-50fps 3M], [640×360-25fps 4M], [640×360-25fps 1.5M], [640×360-25fps 0.7M], [320×180-25fps 4M], [320×180-25fps 1.5M], [320×180-25fps 0.5M] ● Factory setting: [640×360-25fps 0.7M]

**NOTE**

- Cannot be set when [REC FORMAT] is set to UHD.

**[START TRIGGER]**

Sets whether to start streaming with operation of the unit or operation of the application software.

The items that can be set are as follows.

- [CAMERA], [RECEIVER], [RECEIVER(MULTICAST)]  
(Factory setting: [RECEIVER])

**[CONNECTION INFO.]**

Selects the internal memory of the unit or the memory card as the reference location for the transfer destination when starting a stream with the operation of the unit.

The items that can be set are as follows.

- [MEMORY], [SD CARD]  
(Factory setting: [MEMORY])

**[RECEIVER URL]**

Enter the destination URL in following format.

- rtmp://(server URL):(port number)/(path)/(stream key)
- rtmps://(server URL):(port number)/(path)/(stream key)

**[RTSP PORT]**

Assigns the TCP communication port number used for initial RTSP negotiation.

(Factory setting: [554])

**NOTE**

- The following port numbers cannot be set:
  - 0, 20, 21, 23, 25, 42, 53, 67, 68, 69, 80, 110, 123, 161, 162, 443, 995, 10669, 10670, 59000 to 61000
- This unit is generally compatible with the RTSP protocol. The URL for RTSP requests is as follows:  
rtsp://<IP address>/stream
- [RTSP PORT] settings are not possible in the following case:
  - When the setting is other than the [NETWORK] menu → [STREAMING] → [START TRIGGER] → [RECEIVER]

**[MULTICAST ADDRESS]**

Sets the address when using the streaming with the multicast.

(Factory setting: [239.192.0.20])

**[MULTICAST PORT]**

Sets the port number when using the streaming with the multicast.

(Factory setting: [37004])

**[LOAD (SD CARD)]**

Loads the settings file from the memory card and reflects in the menu when [CONNECTION INFO.] is set to [MEMORY].

The items that can be selected are as follows.

- [YES], [NO]

**[SAVE (SD CARD)]**

Encrypts and saves the information of the destination URL to the memory card.

The items that can be selected are as follows.

- [YES], [NO]

**[START]**

Starts streaming.

The items that can be set are as follows.

- [ON], [OFF]  
(Factory setting: [OFF])

**[WLAN PROPERTY]**

Performs settings related to the wireless LAN.

**[TYPE]**

Sets the connection method to the wireless LAN.

[DIRECT]	It can connect directly without using a wireless access point to a device equipped with wireless LAN such as a tablet terminal.
[INFRA(SELECT)]	Connects to the wireless access point. The access point is selected from the list.
[INFRA(MANUAL)]	Connects to the wireless access point. Wireless access point is entered manually.

(Factory setting: [DIRECT])

**[SSID]**

Enters or displays the network name of this unit or the wireless access point (SSID).

Select the following items to set this unit's SSID.

- The [NETWORK] menu → [WLAN PROPERTY] → [TYPE] → [DIRECT]

Enter the SSID for this unit using 32 characters or less.

- Factory default value for this unit's SSID:  
The model number of the unit you are using is set. (For example: [HC-X2000], etc.)

**[CHANNEL]**

Sets the channel to be used when connected to the wireless LAN with following items set.

- The [NETWORK] menu → [WLAN PROPERTY] → [TYPE] → [DIRECT]

The items that can be set are as follows.

- [AUTO], [CH1], [CH6], [CH11]

(Factory setting: [AUTO])

**[ENCRYPTION]**

Sets the encryption method when the [NETWORK] menu → [WLAN PROPERTY] → [TYPE] → [INFRA(SELECT)]/[INFRA(MANUAL)] is selected.

The items that can be set are as follows.

- [WPA-TKIP], [WPA-AES], [WPA2-TKIP], [WPA2-AES], [NONE]

(Factory setting: [WPA2-AES])

**NOTE**

- The setting is fixed to [WPA2-AES] when the [NETWORK] menu → [WLAN PROPERTY] → [TYPE] → [DIRECT] is set.

**[ENCRYPT KEY]**

Sets the encryption key. Set the key using a string of 8 to 63 characters or a hexadecimal number with 64 digits.

(Factory setting: [01234567890123456789abcdef])

**[WLAN IPv4 SETTING]****[DHCP]**

Sets whether to use the automatic acquisition through DHCP or to use the DHCP server function of the unit.

[OFF]	Does not use DHCP.
[CLIENT]	Performs automatic acquisition through DHCP if connecting by setting [WLAN PROPERTY] → [TYPE] → [INFRA(SELECT)]/[INFRA(MANUAL)].
[SERVER]	Enables the DHCP server function of the unit when connecting by setting [WLAN PROPERTY] → [TYPE] → [DIRECT].

(Factory setting: [OFF])

**[IP ADDRESS]**

Sets the IP address.

(Factory setting: [192.168.0.1])

**NOTE**

- Cannot be set when [WLAN IPv4 SETTING] → [DHCP] → [CLIENT] is selected.

**[SUBNET MASK]**

Sets the subnet mask.

(Factory setting: [255.255.255.0])

**NOTE**

- Cannot be set when [WLAN IPv4 SETTING] → [DHCP] → [CLIENT] is selected.

**[DEFAULT GATEWAY]**

Sets the default gateway.

(Factory setting: [192.168.0.254])

**NOTE**

- If you do not use default gateway, set to [0.0.0.0].
- Cannot be set when [WLAN IPv4 SETTING] → [DHCP] → [CLIENT] is selected.
- Disables the setting for the default gateway when [WLAN PROPERTY] → [TYPE] → [DIRECT] is selected.

**[PRIMARY DNS]**

Sets the primary DNS server.

(Factory setting: [0.0.0.0])

**NOTE**

- Disables the setting for the primary DNS server when [WLAN PROPERTY] → [TYPE] → [DIRECT] is selected.

**[SECONDARY DNS]**

Sets the secondary DNS server.

(Factory setting: [0.0.0.0])

**NOTE**

- Disables the setting for the secondary DNS server when [WLAN PROPERTY] → [TYPE] → [DIRECT] is selected.

**[INFORMATION]****[STATUS]**

Displays the status of the network function.



**[UTILITY]**

Performs the various operations related to the network function.

**[NETWORK INITIALIZE]**

Returns the various networks settings to the factory default state and restarts the unit.

**[SYSTEM] menu**

Configure the settings regarding the recording format of video and audio.

**[FREQUENCY]**

Sets the system frequency.

The items that can be set are as follows.

- [59.94Hz], [50.00Hz]
- (Factory setting: [59.94Hz])

**NOTE**

- The unit will restart when the setting is changed.
- When AVCHD clips are recorded, it is not possible to use the same memory card with different system frequencies. When the system frequency is changed, use a different memory card.

**[FILE FORMAT]**

Sets the file format for recording.

[MOV]	Sets to record in the MOV file format of MOV format.
[MP4]	Sets to record in the MP4 file format of MP4 format.
[AVCHD]	Sets to record in the MTS file format of AVCHD format.

(Factory setting: [MOV])

**[REC FORMAT]**

Sets the signal format and codec mode for recording.

The items that can be set are as follows.

[FREQUENCY]	[FILE FORMAT]	Items that can be set
[59.94Hz]	[MOV]	[2160-59.94p/420LongGOP 150M], [2160-59.94p/HEVC LongGOP 200M], [2160-59.94p/HEVC LongGOP 100M], [2160-29.97p/420LongGOP 100M], [2160-29.97p/HEVC LongGOP 150M], [2160-29.97p/422LongGOP 150M], [2160-23.98p/420LongGOP 100M], [2160-23.98p/HEVC LongGOP 150M], [2160-23.98p/422LongGOP 150M], [1080-59.94p/422LongGOP 100M], [1080-59.94p/422ALL-I 200M], [1080-59.94i/422LongGOP 50M], [1080-59.94i/422ALL-I 100M], [1080-29.97p/422LongGOP 50M], [1080-29.97p/422ALL-I 100M], [1080-23.98p/422LongGOP 50M], [1080-23.98p/422ALL-I 100M] ● Factory setting: [2160-59.94p/HEVC LongGOP 200M]
	[MP4]	[2160-59.94p/HEVC LongGOP 100M], [2160-29.97p/420LongGOP 72M], [2160-29.97p/HEVC LongGOP 72M], [2160-23.98p/420LongGOP 72M], [2160-23.98p/HEVC LongGOP 72M], [1080-59.94p/420LongGOP 50M], [1080-23.98p/420LongGOP 50M] ● Factory setting: [2160-59.94p/HEVC LongGOP 100M]
	[AVCHD]	[1080-59.94p/AVCHD PS], [1080-59.94i/AVCHD PH], [1080-59.94i/AVCHD HA], [1080-23.98p/AVCHD PH], [720-59.94p/AVCHD PM] ● Factory setting: [1080-59.94i/AVCHD PH]
[50.00Hz]	[MOV]	[2160-50.00p/420LongGOP 150M], [2160-50.00p/HEVC LongGOP 200M], [2160-50.00p/HEVC LongGOP 100M], [2160-25.00p/420LongGOP 100M], [2160-25.00p/HEVC LongGOP 150M], [2160-25.00p/422LongGOP 150M], [1080-50.00p/422LongGOP 100M], [1080-50.00p/422ALL-I 200M], [1080-50.00i/422LongGOP 50M], [1080-50.00i/422ALL-I 100M], [1080-25.00p/422LongGOP 50M], [1080-25.00p/422ALL-I 100M] ● Factory setting: [2160-50.00p/HEVC LongGOP 200M]
	[MP4]	[2160-50.00p/HEVC LongGOP 100M], [2160-25.00p/420LongGOP 72M], [2160-25.00p/HEVC LongGOP 72M], [1080-50.00p/420LongGOP 50M] ● Factory setting: [2160-50.00p/HEVC LongGOP 100M]
	[AVCHD]	[1080-50.00p/AVCHD PS], [1080-50.00i/AVCHD PH], [1080-50.00i/AVCHD HA], [720-50.00p/AVCHD PM] ● Factory setting: [1080-50.00i/AVCHD PH]

**[SUPER SLOW]**

Sets the super slow recording. Enable this setting to shoot slow motion video.

The items that can be set are as follows.

- [ON], [OFF]

(Factory setting: [OFF])

**NOTE**

- In the following cases, it is fixed to [OFF].
  - When the setting is other than [SYSTEM] menu → [FILE FORMAT] → [MOV]
  - When [SYSTEM] menu → [REC FORMAT] is set to other than [1080-59.94p/422LongGOP 100M], [1080-29.97p/422LongGOP 50M], [1080-23.98p/422LongGOP 50M], [1080-50.00p/422LongGOP 100M], and [1080-25.00p/422LongGOP 50M]
  - When using the face detection/tracking AE&AF function

**[OTHERS] menu**

Configures the settings for writing/loading/initializing user files to the internal memory and other settings of the unit.

**[FILE]**

Saves and loads the setting data.

For the saving and loading target, refer to "Target items for scene file/setup file/initialization". (→ 94)

For details about saving and loading, refer to "Handling setting data". (→ 100)

**[SCENE FILE(SD CARD)]**

Loads or saves scene files on a memory card.

[LOAD]	Selects and loads the scene file saved on the memory card into the unit. Can select if all of the scene files ([F1:] to [F6:]) are loaded, or individually loaded.
[SAVE]	The setting values of the current scene file ([F1:] to [F6:]) are overwritten to the file selected from the list of scene files saved in the memory card.
[SAVE AS]	The setting values of the current scene file ([F1:] to [F6:]) is saved to the memory card as a new scene file by entering the file name.

**[SETUP FILE(SD CARD)]**

Loads or saves setup files on a memory card.

[LOAD]	Selects the setup file saved on the memory card to load on the unit. The unit will automatically restart after loading.
[SAVE]	Overwrites the file selected in the list of the setup files saved on the memory card with the current setting values of the unit.
[SAVE AS]	Enter a file name to save the current setting values in the unit as a new setup file in the memory card.

**[SETUP FILE(MEMORY)]**

Loads/saves/initializes setup files in the internal memory of the unit.

[LOAD]	Loads setup file saved on the memory. The unit will automatically restart after loading.
[SAVE]	Saves the setup file to the memory.
[INITIALIZE]	Restores the factory settings from the current settings for the menus in the setup file. The unit will automatically restart after execution.

**[SLOT FOR LOAD/SAVE]**

Sets the card slot to load and save the scene file, setup file, and streaming setting file.

The items that can be set are as follows.

- [SLOT1], [SLOT2]

(Factory setting: [SLOT1])

**[HANDLE TALLY LED]**

Sets whether the tally lamp is to illuminate or not.

The items that can be set are as follows.

- [ON], [OFF]

(Factory setting: [ON])

**[CLOCK]****[CLOCK SETTING]**

Sets the calendar (date of the built-in clock) and time.

Year	[2018]...[2037]
Month	[JAN]...[DEC] ([1]...[12])
Day	[1]...[31] (This changes according to the year and month settings)
Hour	[0]...[23]
Minute	[0]...[59]

**[TIME ZONE]**

Sets the time zone. It will switch to the time with the time difference added when the time zone setting is changed.

The items that can be set are as follows.

- [- 12:00]...[+ 12:00] (30 minutes steps), [+ 12:45], [+ 13:00]

(Factory setting: [- 5:00])

**[DATE FORMAT]**

Sets the display order of the year, month, and date of the calendar (date of the built-in clock). This is reflected to the date display of the clip information.

The items that can be set are as follows.

- [Y-M-D], [M-D-Y], [D-M-Y]

(Factory setting: [M-D-Y])

**[USB DEVICE]****[CARD READER MODE]**

Switches the unit to the card reader mode. A computer or other device can be connected via USB to use as a card reader of the memory card.

The items that can be selected are as follows.

- [YES], [NO]

**NOTE**

- When switched to card reader mode while using a battery, the LCD monitor turns off after approximately 5 seconds.  
The LCD monitor turns on when you perform the following operations:
  - Turn the multial up or down
  - Touch the LCD monitor
- To exit the card reader mode, do one of the following operations:
  - Turn the power off
  - Press the <EXIT> button
  - Press the multial
  - Touch [↶]

**[SERVICE MODE]**

Switches the unit to the service mode.

You can also check software information (licenses) on a computer and other equipment. Confirm "LICENSE.TXT" for the external drive recognized by a computer.

The items that can be selected are as follows.

- [YES], [NO]

**NOTE**

- When switched to service mode while using a battery, the LCD monitor turns off after approximately 5 seconds.  
The LCD monitor turns on when you perform the following operations:
  - Turn the multial up or down
  - Touch the LCD monitor
- To exit the service mode, do one of the following operations:
  - Turn the power off
  - Press the <EXIT> button
  - Press the multial
  - Touch [↶]

**[INFORMATION]****[VERSION]**

Displays the information of the unit.

[MODEL]	Displays the product name of the unit.
[SERIAL NO.]	Displays the serial number of the unit.
[VERSION]	Displays the firmware version of the unit.

**[OPERATION TIME]**

Displays the total operation time.

**[UPDATE]**

Updates the firmware.

Insert the memory card where the update file is saved into card slot 1.

The items that can be selected are as follows.

- [YES], [NO]

**[ECO MODE]**

By setting [OTHERS] menu → [ECO MODE] → [BATTERY]/[AC]/[NETWORK], when there is no button operation or LCD monitor touch operation performed for a certain time, the power turns off automatically.

 **NOTE**

- In the following cases, even if [BATTERY], [AC], or [NETWORK] is set to [ON], the power will not automatically turn off.
    - While a memory card is being accessed (during recording, during playback, while formatting the media, etc.)
    - During pre-recording
    - In card reader mode
  - In the following case, even if [BATTERY] is set to [ON], the power will not automatically turn off.
    - When using the AC adaptor\*
  - In the following cases, the power will not automatically turn off.
    - When connected to a network via wireless LAN
- \* The power turns off automatically if the [AC] eco mode functions.

**[BATTERY]**

When about 5 minutes have passed without any operation, this unit automatically turns off to save battery life.

The items that can be selected are as follows.

- [ON], [OFF]

(Factory setting: [ON])

**[AC]**

If there are no operations for approximately 15 minutes while using the AC adaptor, the power turns off automatically.

The items that can be selected are as follows.

- [ON], [OFF]

(Factory setting: [ON])

**[NETWORK]**

If there are no operations for approximately 15 minutes when the [NETWORK] menu → [DEVICE SEL] → [WLAN] is set while not connected to the network via a wireless LAN, the power turns off automatically.

The items that can be selected are as follows.

- [ON], [OFF]

(Factory setting: [ON])

**[APPROVED REGULATION]**

Display the authentication information for this unit.

- Select [△]/[▽] and you can show the second page.

**[LANGUAGE]**

Sets the display language.

The items that can be selected are as follows.

[English]	English
[Español]	Spanish
[Français]	French

(Factory setting: [English])

**[MENU INITIALIZE]**

Returns the setting value of the menu to the factory setting. The unit is restarted after executing.

## Factory setting value of the scene file

### [SCENE FILE] menu

The factory settings of the [SCENE FILE] menu and the items that can be selected differ depending on the [SCENE FILE] menu → [FILE SELECT] setting.

Item	[FILE SELECT]					
	[F1:]	[F2:FLUO]	[F3:SPARK]	[F4:STILL]	[F5:CINE V]	[F6:CINE D]
[MASTER DTL]	[0]	[0]	[+3]	[0]	[-4]	[-4]
[DTL CORING]	[1]	[1]	[1]	[1]	[1]	[1]
[V.DTL LEVEL]	[0]	[0]	[0]	[0]	[0]	[0]
<b>[RB GAIN CONTROL SETTING]</b>						
[R GAIN AWB A]	[0]	[0]	[0]	[0]	[0]	[0]
[B GAIN AWB A]	[0]	[0]	[0]	[0]	[0]	[0]
[R GAIN AWB B]	[0]	[0]	[0]	[0]	[0]	[0]
[B GAIN AWB B]	[0]	[0]	[0]	[0]	[0]	[0]
[AWB A GAIN OFFSET]	[OFF]	[OFF]	[OFF]	[OFF]	[OFF]	[OFF]
[AWB B GAIN OFFSET]	[OFF]	[OFF]	[OFF]	[OFF]	[OFF]	[OFF]
[CHROMA LEVEL]	[0]	[0]	[+4]	[0]	[-10]	[-10]
[CHROMA PHASE]	[0]	[0]	[+5]	[0]	[0]	[0]
[MATRIX]	[NORMAL1]	[FLUO.]	[NORMAL2]	[STILL LIKE]	[CINELIKE]	[CINELIKE]
<b>[COLOR CORRECTION]</b>						
[R]	[0]	[0]	[0]	[0]	[0]	[0]
[R-Mg]	[0]	[0]	[0]	[0]	[0]	[0]
[Mg]	[0]	[0]	[0]	[0]	[0]	[0]
[Mg-Mg-B]	[0]	[0]	[0]	[0]	[0]	[0]
[Mg-B-B]	[0]	[0]	[0]	[0]	[0]	[0]
[B]	[0]	[0]	[0]	[0]	[0]	[0]
[B-B-Cy]	[0]	[0]	[0]	[0]	[0]	[0]
[B-Cy-Cy]	[0]	[0]	[0]	[0]	[0]	[0]
[Cy]	[0]	[0]	[0]	[0]	[0]	[0]
[Cy-G]	[0]	[0]	[0]	[0]	[0]	[0]
[G]	[0]	[0]	[0]	[0]	[0]	[0]
[G-G-Y]	[0]	[0]	[0]	[0]	[0]	[0]
[G-Y-Y]	[0]	[0]	[0]	[0]	[0]	[0]
[Y]	[0]	[0]	[0]	[0]	[0]	[0]
[Y-Y-R]	[0]	[0]	[0]	[0]	[0]	[0]
[Y-R-R]	[0]	[0]	[0]	[0]	[0]	[0]
[SKIN TONE DTL.]	[OFF]	[OFF]	[OFF]	[OFF]	[OFF]	[OFF]
[MASTER PED]	[0]	[0]	[0]	[0]	[0]	[0]
[GAMMA MODE SEL]	[HD]	[HD]	[HD]	[STILL LIKE]	[CINE-LIKE V]	[CINE-LIKE D]
[BLACK GAMMA]	[0]	[0]	[-1]	[0]	[0]	[0]
[KNEE MODE]	[AUTO]	[AUTO]	[AUTO]	[AUTO]	[AUTO]	[AUTO]
<b>[WHITE CLIP SETTING]</b>						
[WHITE CLIP]	[ON]	[ON]	[ON]	[ON]	[ON]	[ON]
[WHITE CLIP LEVEL]	[109%]	[109%]	[109%]	[109%]	[109%]	[109%]
[DRS]	[OFF]	[OFF]	[OFF]	[OFF]	[OFF]	[OFF]
[DRS EFFECT DEPTH]	[1]	[1]	[1]	[1]	[1]	[1]
[NR CONTROL]	[0]	[0]	[0]	[0]	[0]	[0]
[AE LEVEL]	[ON]	[ON]	[ON]	[ON]	[ON]	[ON]
[AE LEVEL EFFECT]	[0EV]	[0EV]	[0EV]	[0EV]	[0EV]	[0EV]

## Target items for scene file/setup file/initialization

- SCENE: Items saved in scene files.
- SETUP: Items saved in setup files.
- INITIALIZE: Items that are initialized with the [OTHERS] menu → [MENU INITIALIZE].
- Meaning of the symbols used in the table are as follows.
  - ✓: Is a target.
  - —: Not a target.

\*1 Available for setting when using **X2000**.

### [THUMBNAIL] menu

	Item	SCENE	SETUP	INITIALIZE
[PLAYBACK]	[CLIP SEL]	—	—	✓
	[RESUME PLAY]	—	✓	✓
[CLIP]	[PROTECT]	—	—	—
	[DELETE]	—	—	—
	[COPY]	—	—	—
	[INFORMATION]	—	—	—
[DISPLAY]	[DATA]	—	✓	✓

### [CAMERA] menu

	Item	SCENE	SETUP	INITIALIZE
[SW MODE]	[ZOOM RING]	—	✓	✓
	[IRIS RING]	—	✓	✓
	[SUPER GAIN]	—	✓	✓
	[AGC LIMIT]	—	✓	✓
	[O.I.S.]	—	✓	✓
	[HYBRID O.I.S.]	—	✓	✓
	[O.I.S. MODE]	—	✓	✓
	[ATW]	—	✓	✓
	[ATW SPEED]	—	✓	✓
	[ATW TARGET R]	—	✓	✓
	[ATW TARGET B]	—	✓	✓
	[W.BAL PRESET]	—	✓	✓
	[W.BAL VAR]	—	✓	✓
	[H.ZOOM SPEED]	—	✓	✓
	[i.ZOOM]	—	✓	✓
	[REAR RING]	—	✓	✓
	[AUTO SLOW SHTR]	—	✓	✓
	[AF SPEED]	—	✓	✓
	[AREA MODE]	—	✓	✓
	[IR REC]	—	✓	✓
[IR REC COLOR]	—	✓	✓	
[FACE DETECT/TRACKING MODE]	—	✓	✓	
[USER SW]	[USER1]	—	✓	✓
	[USER2]	—	✓	✓
	[USER3]	—	✓	✓
	[USER4]	—	✓	✓
	[USER5]	—	✓	✓
	[USER6]	—	✓	✓
	[USER7]	—	✓	✓
	[USER8]	—	✓	✓
	[USER9]	—	✓	✓
	[USER10]	—	✓	✓
	[USER11]	—	✓	✓
	[USER12]	—	✓	✓

**[SCENE FILE] menu**

Item		SCENE	SETUP	INITIALIZE
[NAME EDIT]		✓	—	✓
[LOAD/SAVE/INITIALIZE]		—	—	—
[MASTER DTL]		✓	—	✓
[DTL CORING]		✓	—	✓
[V.DTL LEVEL]		✓	—	✓
[RB GAIN CONTROL SETTING]	[R GAIN AWB A]	✓	—	✓
	[B GAIN AWB A]	✓	—	✓
	[R GAIN AWB B]	✓	—	✓
	[B GAIN AWB B]	✓	—	✓
	[AWB A GAIN OFFSET]	✓	—	✓
	[AWB B GAIN OFFSET]	✓	—	✓
[CHROMA LEVEL]		✓	—	✓
[CHROMA PHASE]		✓	—	✓
[MATRIX]		✓	—	✓
[COLOR CORRECTION]	[R]	✓	—	✓
	[R-Mg]	✓	—	✓
	[Mg]	✓	—	✓
	[Mg-Mg-B]	✓	—	✓
	[Mg-B-B]	✓	—	✓
	[B]	✓	—	✓
	[B-B-Cy]	✓	—	✓
	[B-Cy-Cy]	✓	—	✓
	[Cy]	✓	—	✓
	[Cy-G]	✓	—	✓
	[G]	✓	—	✓
	[G-G-YI]	✓	—	✓
	[G-YI-YI]	✓	—	✓
	[YI]	✓	—	✓
	[YI-YI-R]	✓	—	✓
	[YI-R-R]	✓	—	✓
[SKIN TONE DTL.]		✓	—	✓
[MASTER PED]		✓	—	✓
[GAMMA MODE SEL]		✓	—	✓
[BLACK GAMMA]		✓	—	✓
[KNEE MODE]		✓	—	✓
[WHITE CLIP SETTING]	[WHITE CLIP]	✓	—	✓
	[WHITE CLIP LEVEL]	✓	—	✓
[DRS]		✓	—	✓
[DRS EFFECT DEPTH]		✓	—	✓
[NR CONTROL]		✓	—	✓
[AE LEVEL]		✓	—	✓
[AE LEVEL EFFECT]		✓	—	✓

**[AUDIO] menu**

Item		SCENE	SETUP	INITIALIZE
[HANDLE UNIT INPUT SETTING]	[INPUT1 MIC LEVEL]	—	✓	✓
	[INPUT2 MIC LEVEL]	—	✓	✓
	[INPUT1 LINE LEVEL]	—	✓	✓
	[INPUT2 LINE LEVEL]	—	✓	✓
[MIC SETTING]	[CH1 LEVEL]	—	✓	✓
	[CH2 LEVEL]	—	✓	✓
	[CH1 LEVEL CONTROL]	—	✓	✓
	[CH2 LEVEL CONTROL]	—	✓	✓
[INPUT SETTINGS]	[CH1 MIC LOWCUT]	—	✓	✓
	[CH2 MIC LOWCUT]	—	✓	✓
	[CH1 LIMITER]	—	✓	✓
	[CH2 LIMITER]	—	✓	✓
	[MIC LIMITER LINK]	—	✓	✓
[OUTPUT SETTINGS]	[AUDIO OUT]	—	✓	✓
[ALARM]	[BATTERY END]	—	✓	✓
	[MEDIA END]	—	✓	✓
	[WARNING]	—	✓	✓

**[VIDEO OUT/LCD/VF] menu**

Item		SCENE	SETUP	INITIALIZE
[VIDEO OUT SEL]*1		—	✓	✓
[SDI OUT]*1	[OUT FORMAT]	—	✓	✓
	[SDI AUDIO GAIN CHG]	—	✓	✓
	[SDI REC REMOTE]	—	✓	✓
	[SDI OUT CHAR]	—	✓	✓
	[SDI OUT ZEBRA]	—	✓	✓
[HDMI OUT]	[OUT FORMAT]	—	✓	✓
	[HDMI TC OUT]	—	✓	✓
	[HDMI REC REMOTE]	—	✓	✓
	[HDMI OUT CHAR]	—	✓	✓
	[HDMI OUT ZEBRA]	—	✓	✓
[LCD]	[BRIGHTNESS]	—	✓	✓
	[COLOR LEVEL]	—	✓	✓
	[CONTRAST]	—	✓	✓
	[BACK LIGHT]	—	✓	✓
	[RED TINT]	—	✓	✓
	[BLUE TINT]	—	✓	✓
	[SELF SHOOT]	—	✓	✓
[VF]	[BRIGHTNESS]	—	✓	✓
	[COLOR LEVEL]	—	✓	✓
	[CONTRAST]	—	✓	✓
	[RED TINT]	—	✓	✓
	[BLUE TINT]	—	✓	✓
	[VF COLOR]	—	✓	✓



Chapter 4 Operation — Target items for scene file/setup file/initialization

	Item	SCENE	SETUP	INITIALIZE
[INDICATOR]	[FULL AUTO]	—	✓	✓
	[SLOT1/2 STATUS]	—	✓	✓
	[2 SLOTS FUNC.]	—	✓	✓
	[STREAMING]	—	✓	✓
	[NETWORK]	—	✓	✓
	[BATTERY REMAIN]	—	✓	✓
	[REC FORMAT]	—	✓	✓
	[FRAME RATE]	—	✓	✓
	[CLIP NAME]	—	✓	✓
	[REC REMOTE]	—	✓	✓
	[REC MODE]	—	✓	✓
	[FBC]	—	✓	✓
	[DRS]	—	✓	✓
	[O.I.S.]	—	✓	✓
	[SCENE FILE]	—	✓	✓
	[AREA/FACE]	—	✓	✓
	[AUDIO LEVEL METER]	—	✓	✓
	[GAIN]	—	✓	✓
	[ND FILTER]	—	✓	✓
	[SHUTTER]	—	✓	✓
	[IRIS]	—	✓	✓
	[AE LEVEL]	—	✓	✓
	[ZOOM/FOCUS]	—	✓	✓
	[WHITE BALANCE]	—	✓	✓
	[FACE DETECTION]	—	✓	✓
	[DATE/TIME]	—	✓	✓
	[MULTI MANUAL]	—	✓	✓
	[D.ZOOM]	—	✓	✓
	[IR REC]	—	✓	✓
	[PLAYBACK STATUS]	—	✓	✓
[MARKER]	[CENTER MARKER]	—	✓	✓
	[SAFETY MARKER]	—	✓	✓
	[FRAME MARKER]	—	✓	✓
[FOCUS ASSIST]	[FOCUS ASSIST SW]	—	✓	✓
	[EXPAND MODE]	—	✓	✓
	[EXPAND VALUE]	—	✓	✓
	[PEAKING LEVEL]	—	✓	✓
	[PEAKING COLOR]	—	✓	✓
	[DETAIL]	—	✓	✓
	[DETAIL LEVEL]	—	✓	✓
[DETAIL FREQ.]	—	✓	✓	
[EI ASSIST]	[ZEBRA]	—	✓	✓
	[ZEBRA1 DETECT]	—	✓	✓
	[ZEBRA2 DETECT]	—	✓	✓
	[ZEBRA2]	—	✓	✓
	[WFM MODE]	—	✓	✓
	[WFM TRANSPARENCE]	—	✓	✓
[LEVEL GAUGE]	[LEVEL GAUGE]	—	✓	✓
	[LEVEL GAUGE RESET]	—	—	—

**[RECORDING] menu**

Item	SCENE	SETUP	INITIALIZE
[FORMAT MEDIA]	—	—	—
[CLIP NAME]	[CAM INDEX]	—	✓
	[NEXT CARD COUNT]	—	✓
[2 SLOTS FUNC.]	—	✓	✓
[PRE REC]	—	✓	✓
[REC FUNCTION]	[REC MODE]	—	✓
	[INTERVAL TIME]	—	✓
[TC/UB]	[TC PRESET]	—	—
	[UB PRESET]	—	—
	[FREE/REC RUN]	—	✓
	[DF/NDF]	—	✓
	[UB MODE]	—	✓
[REC COUNTER]	—	✓	✓
[TIME STAMP]	—	✓	✓

**[NETWORK] menu**

Item	SCENE	SETUP	INITIALIZE
[DEVICE SEL]	—	✓	✓
[NETWORK FUNC]	—	✓	✓
[IP REMOTE]	[ENABLE/DISABLE]	—	✓
	[USER ACCOUNT]	—	—
	[ACCOUNT LIST]	—	✓
[STREAMING]	[STREAMING FORMAT]	—	✓
	[START TRIGGER]	—	✓
	[CONNECTION INFO.]	—	✓
	[RECEIVER URL]	—	✓
	[RTSP PORT]	—	✓
	[MULTICAST ADDRESS]	—	✓
	[MULTICAST PORT]	—	✓
	[LOAD (SD CARD)]	—	—
	[SAVE (SD CARD)]	—	—
	[START]	—	—
[WLAN PROPERTY]	[TYPE]	—	✓
	[SSID]	—	—
	[CHANNEL]	—	✓
	[ENCRYPTION]	—	✓
	[ENCRYPT KEY]	—	—
[WLAN IPv4 SETTING]	[DHCP]	—	✓
	[IP ADDRESS]	—	✓
	[SUBNET MASK]	—	✓
	[DEFAULT GATEWAY]	—	✓
	[PRIMARY DNS]	—	✓
	[SECONDARY DNS]	—	✓
[INFORMATION]	[STATUS]	—	—
[UTILITY]	[NETWORK INITIALIZE]	—	—

**[SYSTEM] menu**

Item	SCENE	SETUP	INITIALIZE
[FREQUENCY]	—	✓	✓
[FILE FORMAT]	—	✓	✓
[REC FORMAT]	—	✓	✓
[SUPER SLOW]	—	✓	✓

**[OTHERS] menu**

Item		SCENE	SETUP	INITIALIZE
[FILE]	[SCENE FILE(SD CARD)]	—	—	—
	[SETUP FILE(SD CARD)]	—	—	—
	[SETUP FILE(MEMORY)]	—	—	—
	[SLOT FOR LOAD/SAVE]	—	✓	✓
[HANDLE TALLY LED]		—	✓	✓
[CLOCK]	[CLOCK SETTING]	—	—	—
	[TIME ZONE]	—	—	—
	[DATE FORMAT]	—	✓	✓
[USB DEVICE]	[CARD READER MODE]	—	—	—
	[SERVICE MODE]	—	—	—
[INFORMATION]	[VERSION]	—	—	—
	[OPERATION TIME]	—	—	—
	[UPDATE]	—	—	—
[ECO MODE]	[BATTERY]	—	✓	✓
	[AC]	—	✓	✓
	[NETWORK]	—	✓	✓
[APPROVED REGULATION]		—	—	—
[LANGUAGE]		—	✓	✓
[MENU INITIALIZE]		—	—	—

## Handling setting data

### Scene files

#### File structure of the setting data

The scene files of [F1:] to [F6:] can be saved in the main unit memory in accordance to the scene file number.

What can be saved as a scene file is the setting contents of the [SCENE FILE] menu.

In addition, the current setting values of the scene files of [F1:] to [F6:] can be saved as a file to the main unit memory and the memory card, and that data can be loaded and used in the unit.

Setting data file structure of the unit is as follows.

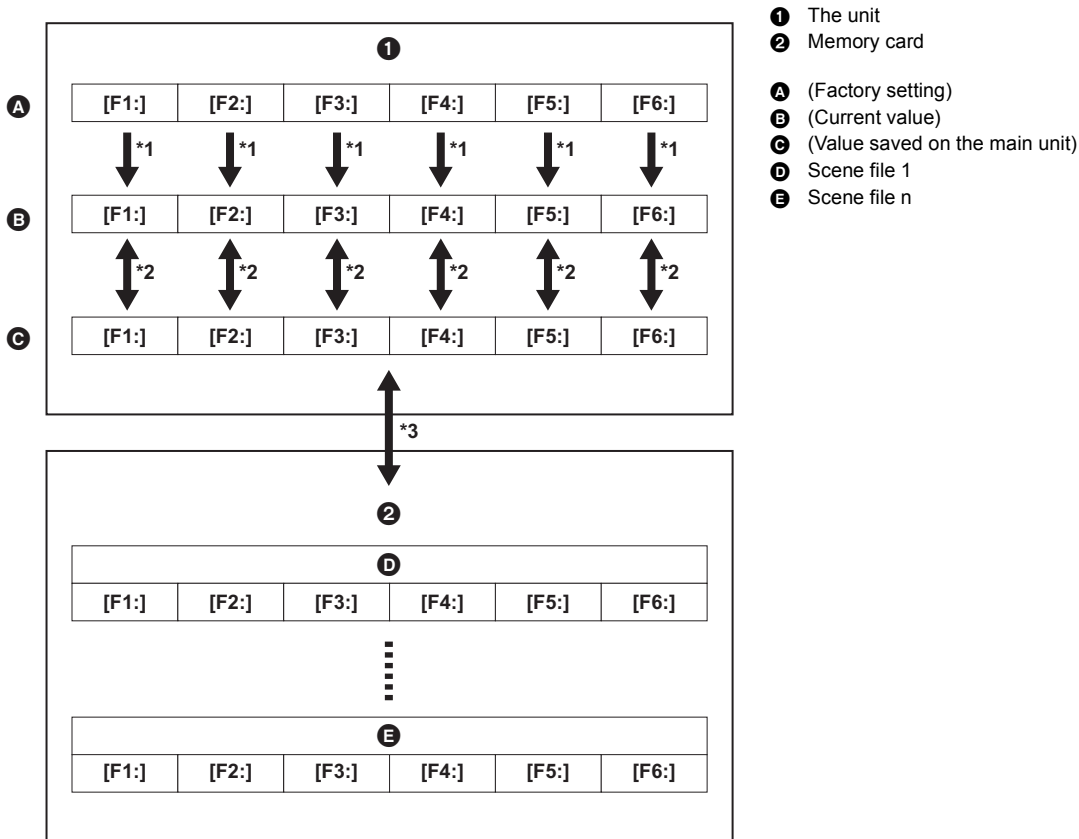

\*1 The scene file can be initialized.

Select the [SCENE FILE] menu → [LOAD/SAVE/INITIALIZE] → [INITIALIZE].

\*2 Current setting value of each scene file can be individually saved in the main unit memory. Also, the scene files saved in the main unit memory can be loaded.

Select the [SCENE FILE] menu → [LOAD/SAVE/INITIALIZE] → [LOAD]/[SAVE].

\*3 The scene file can be saved to the memory card in card slot 1. Also, the scene files saved in the memory card can be loaded.

### Saving the scene file

#### Saving the scene file into the main unit memory

Saves the current setting value of the unit into the main unit memory.

**1** Select the [SCENE FILE] menu → [LOAD/SAVE/INITIALIZE] → [SAVE].

**2** Select [SET].

The file is saved.

#### Saving the scene file to the memory card

The scene file can be overwritten to a file on the memory card in card slot 1, or saved as a new file.

##### ■ Saving the scene file as a new file to the memory card

Specify a file name to save the current setting values of the unit to the memory card in card slot 1 as a new file.

**1** Select the [OTHERS] menu → [FILE] → [SCENE FILE(SD CARD)] → [SAVE AS].

The file name entry screen and the keyboard are displayed.

**2** Enter the text to set with the keyboard.

- For information about entering text, refer to page 178.

**3 Select [Enter].**

A confirmation screen is displayed.

**4 Select [SET].**

The file is saved.

- An error message may be displayed. For details about the error message, refer to "Cases indicated by error messages". (→ 188)

**■ Saving the scene file by overwriting a file on the memory card**

Overwrite the file selected in the list of scene files saved in the memory card in card slot 1 with the current setting values of the unit.

**1 Select the [OTHERS] menu → [FILE] → [SCENE FILE(SD CARD)] → [SAVE].**

The list of scene files saved in the memory card in card slot 1 is displayed.

**2 Select the file to overwrite from the list of scene files.**

The file name entry screen and the keyboard are displayed. Leave it as is when overwriting.

**3 Select [Enter].**

A confirmation screen is displayed.

**4 Select [SET].**

The file is saved.

**Loading the scene file**

Load the scene files saved to the main unit memory or the memory card in card slot 1.

**Loading the scene file from the main unit memory****1 Select the [SCENE FILE] menu → [LOAD/SAVE/INITIALIZE] → [LOAD].****2 Select [SET].**

The file is loaded.

**Loading the scene file from the memory card****1 Select the [OTHERS] menu → [FILE] → [SCENE FILE(SD CARD)] → [LOAD].**

The list of scene files stored in the specified folder of the memory card in card slot 1 is displayed.

**2 Select the file name for the file to load.****3 Selects if all of the scene files ([F1:] to [F6:]) are loaded, or individually loaded.**

- To load all, select [ALL].
- To load individually, select the scene number to load.

**4 Select [SET].**

The file is loaded.

- An error message may be displayed. For details about the error message, refer to "Cases indicated by error messages". (→ 188)

**Initialization of the scene file**

Initializes the scene file saved in the main unit memory.

**1 Select the scene file to return to the factory setting in the [SCENE FILE] menu → [FILE SELECT].****2 Select the [SCENE FILE] menu → [LOAD/SAVE/INITIALIZE] → [INITIALIZE].**

The confirmation screen is displayed.

**3 Select [SET].**

The selected scene file returns to the factory setting.

**Changing the scene file name**

Changes the name of the scene file saved in the main unit memory.

Only changeable part is the title section of the scene file name. As an example, if the scene file name is [F6:CINE D], only the "CINE D" part can be changed.

**1 Select the scene file to change the name in the [SCENE FILE] menu → [FILE SELECT].****2 Select the [SCENE FILE] menu → [NAME EDIT].**

The file name entry screen and the keyboard are displayed.

**3 Enter the text to set with the keyboard.**

- Enter a maximum of 8 alphanumeric characters.
- For information about entering text, refer to page 178.

**4 Select [Enter].**

The file name is updated.

## Setup file

You can save the setting information for this unit to the main unit memory or a memory card in card slot 1, and load it from a memory card into this unit.

### Saving the setup file

The setup file can be overwritten to a file on the main unit memory or memory card in card slot 1, or saved as a new file.

#### Saving the setup file as a new file to the memory card

Specify a file name to save the current setting values of the unit to the memory card in card slot 1 as a new file.

**1 Select the [OTHERS] menu → [FILE] → [SETUP FILE(SD CARD)] → [SAVE AS].**

The file name entry screen and the keyboard are displayed.

**2 Enter the text to set with the keyboard.**

**3 Select [Enter].**

A confirmation screen is displayed.

**4 Select [SET].**

The file is saved.

- An error message may be displayed. For details about the error message, refer to "Cases indicated by error messages". (→ 188)

#### Saving the setup file by overwriting a file on the memory card

Overwrites the file selected in the list of the setup files saved on the memory card with the current setting values of the unit.

**1 Select the [OTHERS] menu → [FILE] → [SETUP FILE(SD CARD)] → [SAVE].**

The list of setup files saved on the memory card in card slot 1 is displayed.

**2 Select the file to overwrite from the list of setup files.**

The file name entry screen and the keyboard are displayed. Leave it as is when overwriting.

**3 Select [Enter].**

A confirmation screen is displayed.

**4 Select [SET].**

The file is saved.

#### Saving the setup file to the main unit memory

Saves the current setting value of the unit into the main unit memory.

**1 Select the [OTHERS] menu → [FILE] → [SETUP FILE(MEMORY)] → [SAVE].**

**2 Select [SET].**

The file is saved.

### Loading the setup file

#### Loading setup files from the memory card

Loads the setup file saved on the memory card in card slot 1.

**1 Select the [OTHERS] menu → [FILE] → [SETUP FILE(SD CARD)] → [LOAD].**

The list of setup files stored in the specified folder of the memory card in card slot 1 is displayed.

- You can also either press the USER button assigned to [LOAD SETUP FILE] or touch the USER button icon to display the list of setup files.

**2 Select the file name for the file to load.**

**3 Select [SET].**

Loading of the file is started. The unit is restarted after loading.

- An error message may be displayed. For details about the error message, refer to "Cases indicated by error messages". (→ 188)
- The file saved by a camera with different firmware version may not be able to load.

#### Loading setup files from the main unit memory

Loads the setup file saved on the main unit memory.

**1 Select the [OTHERS] menu → [FILE] → [SETUP FILE(MEMORY)] → [LOAD].**

**2 Select [SET].**

Loading of the file is started. The unit is restarted after loading.

## Chapter 5

# Shooting

---

This chapter describes the basic procedure for recording. This chapter also describes the special recording method.

## Shooting

For shooting, use the following steps.

- To use the REC button (on the handle) and tally lamp, attach the handle unit ( X2000 supplied, X1500 optional) to the unit.

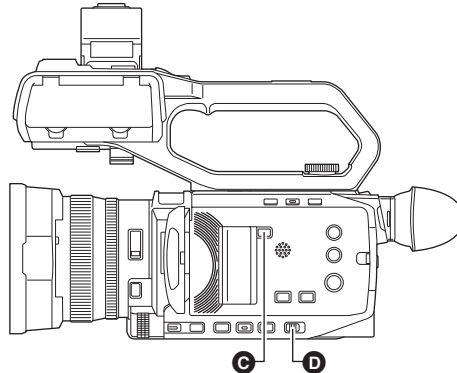
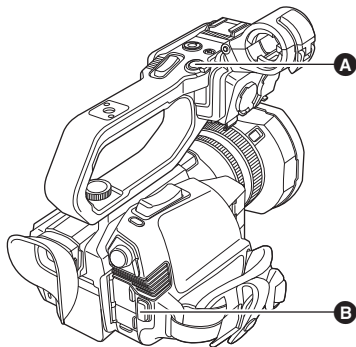

- A** REC button (on the handle)
- B** REC button (on the grip)

- C** <SLOT SEL> button
- D** <AUTO/MANU> switch

### 1 Make settings before recording.

- Before shooting, the followings must be set or adjusted.
  - Image settings for the brightness function (iris, gain, shutter) and the white balance adjustment function, etc.
  - Audio input settings for audio recording.
  - Adjusting audio recording level
- Press the <SLOT SEL> button to select the memory card to record to.

### 2 Select shooting mode with the <AUTO/MANU> switch.

### 3 Start the recording by pressing the REC button.

- One REC button is located on both the handle and the grip.
- The tally lamp is illuminated in red while recording.

### 4 Press the REC button again to stop.

#### ■ About the screen displays during recording



TCG 00:00:00.00	Time data (→ 47)
1/2	Card slot number (recording target) ● is displayed on the left during recording.
1/2	Card slot number
999min	Remaining recording capacity in the memory card ● The display flashes when the remaining recording capacity falls below 2 minutes.
2160-59.94p	Resolution, frame rate (→ 105)
MOV HEVC 200M	File format, recording format (→ 105)

#### ■ About auto mode/manual mode

Switch between auto mode and manual mode with the <AUTO/MANU> switch.

<AUTO>: auto mode

- [A] is displayed at the upper part of the viewfinder and LCD monitor.
- Focus, iris, gain, shutter, and white balance are automatically adjusted.

<MANU>: manual mode

- To adjust focus, iris, gain, shutter speed, and white balance manually, set the unit to manual mode.
- To adjust the brightness, make adjustments to the iris, the AE level, and the ND filter. (→ 108)
- To focus manually, use the focus operation. (→ 111)
- To adjust the white balance, adjust the white balance and black balance. (→ 114)
- To adjust the setting of the audio input and the recording level, switch audio input. (→ 125)

#### NOTE

- The settings made in manual mode are not maintained for the following settings when you switch to auto mode:
  - Focus, lens stop, gain, shutter speed, white balance

#### ■ Camera operations that are disabled in auto mode

- The following camera operations are disabled in auto mode:
  - <IRIS> button, <GAIN> button, <SHUTTER> button, <WHITE BAL> button, <FOCUS A/M/∞> button, focus ring, rear ring\*

\* When set with the [CAMERA] menu → [SW MODE] → [REAR RING] → [IRIS]

- The following USER button functions are disabled in auto mode:
  - [AWB]/[FBC]/[ONE PUSH AF]/[ATW]/[FOCUS ASSIST]



## Check videos recorded

By pressing either the USER button\* assigned to [REC CHECK] or touching the USER button icon after recording, you can automatically play back the last approximately 3 seconds of the clip you have just recorded.

\* [REC CHECK] is set in the <USER5> button at the time of purchase.

- Returns to recording standby after checking.

### NOTE

- REC check will not operate in following cases.
  - When the power is turned ON/OFF
  - When restarted
  - When the <THUMBNAIL> button is pressed
  - When the memory card is inserted/ejected
  - When formatted the memory card
  - When the <SLOT SEL> button has been pressed to switch the card slot to be recorded to
  - When switched to [CARD READER MODE] or [SERVICE MODE]
  - When the [RECORDING] menu → [2 SLOTS FUNC.] → [SIMUL REC]/[BACKGR REC] is set
  - When the [RECORDING] menu → [REC FUNCTION] → [REC MODE] → [INTERVAL] is set
  - When either of the following settings are changed
    - [SYSTEM] menu → [FREQUENCY]
    - [SYSTEM] menu → [FILE FORMAT]
    - [SYSTEM] menu → [REC FORMAT]
    - [RECORDING] menu → [2 SLOTS FUNC.]
- Refer to page 50 for USER button settings.

## Selecting the resolution, codec, and frame rate for recording video

The resolution, codec, and frame rate of the recording video can be selected.

- [SYSTEM] menu → [FREQUENCY]: System frequency
- [SYSTEM] menu → [FILE FORMAT]: File format for recording
- [SYSTEM] menu → [REC FORMAT]: Sets the signal format and codec mode for recording.
- [SYSTEM] menu → [SUPER SLOW]: Super slow recording settings

### ■ How to read a [REC FORMAT] setting

The item names for recording formats indicate the resolution, the frame rate, the codec mode, and the bit rate.

(However, bit rate is not included with some file formats.)

For example: When the recording format for file format [MOV] is [2160-59.94p/HEVC LongGOP 200M]

**2160 - 59.94p / HEVC LongGOP 200M**

**A**   **B**   **C**   **D**

- A** Resolution
- B** Frame rate
- C** Codec mode
- D** Average bit rate

- The resolutions that can be set with this unit are as follows:
  - 2160: UHD (3840×2610), 1080: FHD (1920×1080), 720: HD (1280×720)
- Smoother motion picture can be recorded with the higher value for the frame rate. [i] and [p] of the frame rate means interlace and progressive respectively.

#### Interlace (interlacing scanning):

Video signal that divides the effective scanning lines to half and send them alternatively

#### Progressive (progressive scanning):

High density video signal sending the effective scanning lines simultaneously (It will be higher quality image than the interlace.)

- The image quality gets higher the larger the bit rate number. However, this is not the case when the codec mode is [ALL-I]. (This is because the compression method is different.)
- When the codec mode is [ALL-I], recording is with ALL-Intra.
  - In this method, compression is performed at the individual frame level, so the file size increases, but it is possible to reduce the degradation of image quality during the editing process.
- Depending on the file format settings and bit rate of the recording format, the required Speed Class for the memory cards will differ. Use the compatible memory cards. For details, refer to “Speed Class during shooting” on page 39.

## When [FILE FORMAT] is set to [MOV]

## ■ Video

Resolution	[FREQUENCY]	[REC FORMAT]	YUV, number of bits	Average bit rate
UHD (3840×2160)	[59.94Hz]	[2160-59.94p/420LongGOP 150M]	4:2:0 8 bit	150 Mbps (VBR)
		[2160-59.94p/HEVC LongGOP 200M]	4:2:0 10 bit	200 Mbps (VBR)
		[2160-59.94p/HEVC LongGOP 100M]		100 Mbps (VBR)
		[2160-29.97p/420LongGOP 100M]	4:2:0 8 bit	100 Mbps (VBR)
		[2160-29.97p/HEVC LongGOP 150M]	4:2:0 10 bit	150 Mbps (VBR)
		[2160-29.97p/422LongGOP 150M]	4:2:2 10 bit	
		[2160-23.98p/420LongGOP 100M]	4:2:0 8 bit	100 Mbps (VBR)
		[2160-23.98p/HEVC LongGOP 150M]	4:2:0 10 bit	150 Mbps (VBR)
	[2160-23.98p/422LongGOP 150M]	4:2:2 10 bit		
	[50.00Hz]	[2160-50.00p/420LongGOP 150M]	4:2:0 8 bit	150 Mbps (VBR)
		[2160-50.00p/HEVC LongGOP 200M]	4:2:0 10 bit	200 Mbps (VBR)
		[2160-50.00p/HEVC LongGOP 100M]		100 Mbps (VBR)
		[2160-25.00p/420LongGOP 100M]	4:2:0 8 bit	100 Mbps (VBR)
		[2160-25.00p/HEVC LongGOP 150M]	4:2:0 10 bit	150 Mbps (VBR)
[2160-25.00p/422LongGOP 150M]		4:2:2 10 bit		
FHD (1920×1080)	[59.94Hz]	[1080-59.94p/422LongGOP 100M]	4:2:2 10 bit	100 Mbps (VBR)
		[1080-59.94p/422ALL-I 200M]		200 Mbps (VBR)
		[1080-59.94i/422LongGOP 50M]		50 Mbps (VBR)
		[1080-59.94i/422ALL-I 100M]		100 Mbps (VBR)
		[1080-29.97p/422LongGOP 50M]		50 Mbps (VBR)
		[1080-29.97p/422ALL-I 100M]		100 Mbps (VBR)
		[1080-23.98p/422LongGOP 50M]		50 Mbps (VBR)
		[1080-23.98p/422ALL-I 100M]		100 Mbps (VBR)
	[50.00Hz]	[1080-50.00p/422LongGOP 100M]	4:2:2 10 bit	100 Mbps (VBR)
		[1080-50.00p/422ALL-I 200M]		200 Mbps (VBR)
		[1080-50.00i/422LongGOP 50M]		50 Mbps (VBR)
		[1080-50.00i/422ALL-I 100M]		100 Mbps (VBR)
		[1080-25.00p/422LongGOP 50M]		50 Mbps (VBR)
		[1080-25.00p/422ALL-I 100M]		100 Mbps (VBR)

## ■ Audio

Codec	Number of channels	Number of quantizing bits	Sampling frequency
LPCM	2ch	24 bits	48 kHz

## When [FILE FORMAT] is set to [MP4]

## ■ Video

Resolution	[FREQUENCY]	[REC FORMAT]	YUV, number of bits	Average bit rate
UHD (3840×2160)	[59.94Hz]	[2160-59.94p/HEVC LongGOP 100M]	4:2:0 10 bit	100 Mbps (VBR)
		[2160-29.97p/420LongGOP 72M]	4:2:0 8 bit	72 Mbps (VBR)
		[2160-29.97p/HEVC LongGOP 72M]	4:2:0 10 bit	
		[2160-23.98p/420LongGOP 72M]	4:2:0 8 bit	
		[2160-23.98p/HEVC LongGOP 72M]	4:2:0 10 bit	
	[50.00Hz]	[2160-50.00p/HEVC LongGOP 100M]	4:2:0 10 bit	100 Mbps (VBR)
		[2160-25.00p/420LongGOP 72M]	4:2:0 8 bit	72 Mbps (VBR)
		[2160-25.00p/HEVC LongGOP 72M]	4:2:0 10 bit	
FHD (1920×1080)	[59.94Hz]	[1080-59.94p/420LongGOP 50M]	4:2:0 8 bit	50 Mbps (VBR)
		[1080-23.98p/420LongGOP 50M]		
	[50.00Hz]	[1080-50.00p/420LongGOP 50M]		

## ■ Audio

Codec	Number of channels	Number of quantizing bits	Sampling frequency
AAC	2ch	16 bits	48 kHz

## When [FILE FORMAT] is set to [AVCHD]

## ■ Video

Resolution	[FREQUENCY]	[REC FORMAT]	YUV, number of bits	Average bit rate
FHD (1920×1080)	[59.94Hz]	[1080-59.94p/AVCHD PS]	4:2:0 8 bit	25 Mbps (VBR)
		[1080-59.94i/AVCHD PH]		21 Mbps (VBR)
		[1080-59.94i/AVCHD HA]		17 Mbps (VBR)
		[1080-23.98p/AVCHD PH]		21 Mbps (VBR)
	[50.00Hz]	[1080-50.00p/AVCHD PS]		25 Mbps (VBR)
		[1080-50.00i/AVCHD PH]		21 Mbps (VBR)
		[1080-50.00i/AVCHD HA]		17 Mbps (VBR)
HD (1280×720)	[59.94Hz]	[720-59.94p/AVCHD PM]		8 Mbps (VBR)
	[50.00Hz]	[720-50.00p/AVCHD PM]		

## ■ Audio

Codec	Number of channels	Number of quantizing bits	Sampling frequency
Dolby Audio™	2ch	16 bits	48 kHz

## NOTE

- For the recordable times when using a battery, refer to “Standard charging time and recordable time” (→ 30).
- [FILE FORMAT] is set to [MOV] and [REC FORMAT] is set to [2160-59.94p/HEVC LongGOP 200M] at the time of purchase.
- For a guide to recording times, refer to “Recording time of the memory card” (→ 42).
- A mosaic-like noise may occur during playback when you make large or fast movements with the unit during recording or if you record subjects that move a lot. (When recording AVCHD clips)

## About recording formats and recording functions

The file formats and recording formats corresponding to the recording functions are as follows. \*

\* It is not possible to use recording functions with different file formats and recording formats.

Recording functions	[FILE FORMAT]	[REC FORMAT]
Relay recording (→ 129) Simultaneous recording (→ 130)	All	All
Background recording (→ 131)	[MOV]	FHD (1920×1080) recording format
Interval recording (→ 132)		All
Super slow recording (→ 124)		[1080-59.94p/422LongGOP 100M], [1080-29.97p/422LongGOP 50M], [1080-23.98p/422LongGOP 50M], [1080-50.00p/422LongGOP 100M], [1080-25.00p/422LongGOP 50M]

## Adjustable settings when shooting

Adjust the iris and gain when shooting.

- You can adjust the iris (the lens stop) and the AE level (exposure compensation) with the rear ring or the multi manual function.
- Gain and shutter speed can be adjusted with the multi manual function.

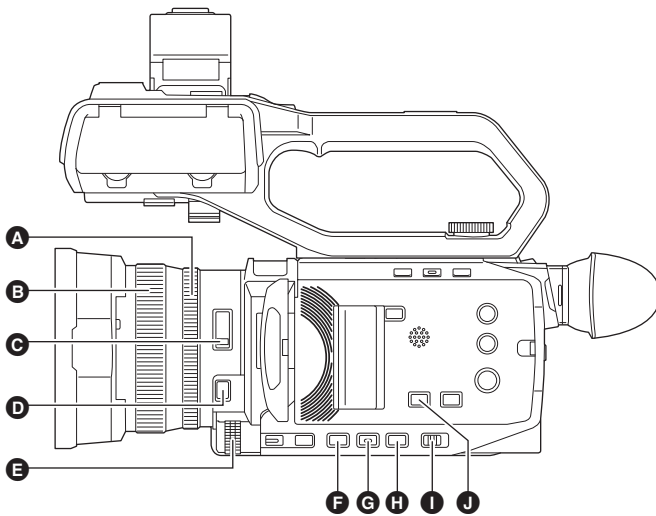

- A** Rear ring
- B** Focus ring
- C** <ND FILTER> switch
- D** <FOCUS A/M/∞> button
- E** Multidial
- F** <IRIS> button
- G** <GAIN> button
- H** <SHUTTER> button
- I** <AUTO/MANU> switch
- J** <AE LEVEL>/<USER4> button

### Iris

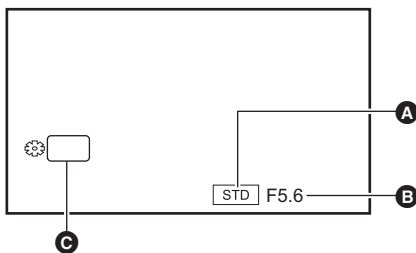

- A** Auto iris icon
  - Displayed when in the auto iris mode.
- B** Iris value
- C** IRIS

### Adjusting with the rear ring

- 1 Select the [CAMERA] menu → [SW MODE] → [REAR RING] → [IRIS] or [IRIS/AE LEVEL].
- 2 Switch to manual mode with the <AUTO/MANU> switch. (→ 104)
- 3 Press the <IRIS> button to switch to manual iris mode.  
[STD] disappears.
- 4 Rotate the rear ring.

#### ■ Iris value

CLOSE ↔ (F11 to F1.9) ↔ OPEN

- Value closer to CLOSE darken the image.
- Value closer to OPEN brighten the image.

### Setting with the multi manual function

- 1 Select the [CAMERA] menu → [SW MODE] → [REAR RING] → [ZOOM].
- 2 Press the <IRIS> button to switch to manual iris mode.  
The iris display is highlighted in orange.
- 3 Turn the multidial to adjust, then press the multidial.  
The setting changes to the value displayed and exits.  
Press the <EXIT> button to exit without changing the setting.

## Applications for the USER button

When adjusting the iris (the lens stop), it is convenient to use the following USER button functions.

[BACKLIGHT]	Switches to the auto iris control for backlight compensation. Prevents the subject darkening due to backlight coming from behind and hitting them, so you can brighten the images on the screen. <ul style="list-style-type: none"> <li>• The auto iris icon changes to [BACK].</li> <li>• [BACKLIGHT] is set in the &lt;USER2&gt; button at the time of purchase.</li> </ul>
[SPOTLIGHT]	Switches to the auto iris control for the spotlight. Even extremely bright subjects can be recorded well. <ul style="list-style-type: none"> <li>• The auto iris icon changes to [SPOT].</li> </ul>

- Refer to page 50 for USER button settings.

### NOTE

- Iris adjustments are not possible when IR recording is enabled.
- Depending on the zoom magnification, there are iris values that are not displayed.
- In Auto Gain Mode or Auto Shutter Mode, the screen brightness may not change even if you adjust the iris. (→ 109, 112)

## Gain

If the camera screen is dark, increase the gain to brighten the screen.

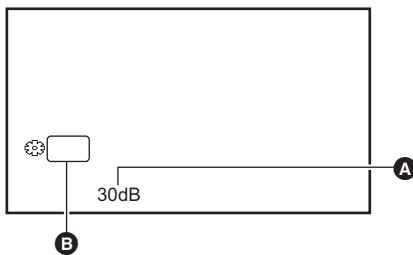

- A** Gain value
  - [AGC] is displayed in auto gain mode and dB is displayed in manual gain mode.
- B** GAIN

**1** Switch to manual mode with the <AUTO/MANU> switch. (→ 104)

**2** Press the <GAIN> button to switch to manual gain mode.

The gain display is highlighted in orange.

**3** Turn the multial to adjust, then press the multial.

The setting changes to the value displayed and exits.

Press the <EXIT> button to exit without changing the setting.

### ■ Gain value

#### 0 dB to 30 dB

- Value closer to 0 dB darken the image.
- Value closer to 30 dB brighten the image.

### NOTE

- The set gain value is not maintained in the following cases:
  - The <GAIN> button is pressed
  - When switched to auto mode
- Screen noise increases when you raise the gain value.
- When auto iris mode or auto shutter mode is enabled, the brightness of the screen may not change even when you adjust the gain. (→ 108, 112)

## Super gain

You can set super gain when recording in dark places.

**1** In [CAMERA] menu → [SW MODE] → [SUPER GAIN], select one of [SUPER GAIN], [SUPER GAIN+], or [ALL].

**2** Either press the USER button assigned to [S.GAIN] or touch the USER button icon. (→ 50)

Gain switches to the one selected in Step 1.

- The gain value switches to [SG] or [SG+].
- When [ALL] is selected in Step 1, each time you either press the USER button or touch the USER button icon, the selection changes in the order [SG] ([SUPER GAIN]), [SG+] ([SUPER GAIN+]), normal gain.

### NOTE

- Super gain is cleared in the following cases:
  - When the power is turned off
  - When the <AUTO/MANU> switch is switched
  - The <GAIN> button is pressed in manual mode

## AE level (exposure compensation)

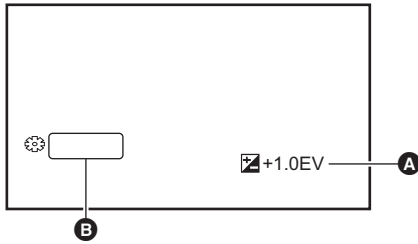

- A** Exposure compensation value
- B** AE LEVEL

### Adjusting with the rear ring

- 1** Select the [SCENE FILE] menu → [AE LEVEL] → [ON].
- 2** Select the [CAMERA] menu → [SW MODE] → [REAR RING] → [IRIS/AE LEVEL].
- 3** When the <AUTO/MANU> switch is set to manual mode, use one of the following operations to switch one of iris, gain, or shutter speed to auto.
  - Press the <IRIS> button to switch to auto iris mode.
  - Press the <GAIN> button to switch to auto gain mode.
  - Press the <SHUTTER> button to switch to auto shutter mode.

### 4 Rotate the rear ring.

At this time, the settings in [SCENE FILE] menu → [AE LEVEL EFFECT] are not reflected.

#### NOTE

- When manual iris mode is enabled, the iris is adjusted when the rear ring is turned.

### Setting with the multi manual function

- 1** Select the [SCENE FILE] menu → [AE LEVEL] → [ON].
- 2** Select the [CAMERA] menu → [SW MODE] → [REAR RING] → [ZOOM] or [IRIS].
- 3** Switch one of iris, gain, or shutter speed to auto.
- 4** Turn the multi-dial to display  AE LEVEL].
- 5** Press the multi-dial.  
The AE level display is highlighted in orange.
- 6** Turn the multi-dial to adjust, then press the multi-dial.  
The setting changes to the value displayed and exits.  
Press the <EXIT> button to exit without changing the setting.

### Applications for the USER button

You can also either press the USER button assigned to [AE LEVEL] or touch the USER button icon to switch enable/disable of [AE LEVEL].

- [AE LEVEL] is set in the <AE LEVEL>/<USER4> button at the time of purchase.
- Refer to page 50 for USER button settings.

#### NOTE

- AE level adjustments are not possible when IR recording is enabled.

## Brightness adjustment

When the external light is strong, you can switch the ND filter (brightness adjustment filter) to use with the <ND FILTER> switch.

### 1 Change the setting of the <ND FILTER> switch.

<1/64>: Reduces the amount of light entering the MOS sensor to 1/64.

<1/16>: Reduces the amount of light entering the MOS sensor to 1/16.

<1/4>: Reduces the amount of light entering the MOS sensor to 1/4.

<CLR>: Does not use the ND filter.

- If the selected setting <1/64>, <1/16> or <1/4> does not match an ND filter setting recommended by this unit, the recommended setting will be displayed on the screen, blink for approximately 5 seconds and disappear.

- A** ND filter setting value
- B** Recommended ND filter setting value

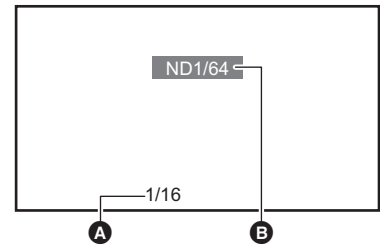

### NOTE

- The ND filter cannot be used when IR recording is enabled.
- The recommended ND filter setting value may not be displayed correctly when the scene is too dark.

## Focusing (manual focus)

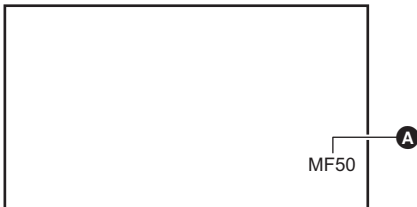

- A** Focus value
  - The focus mode ([AF]/[MF]) and the focus value are displayed.
  - The units for the focus value can be changed in the [ZOOM/FOCUS] menu. (→ 80)

### 1 Switch to manual mode with the <AUTO/MANU> switch. (→ 104)

### 2 Press the <FOCUS A/M/∞> button to switch to manual focus mode.

[AF] and [MF] switch each time you press the button. The focal point goes to infinity after you press and hold the button, and then the manual focus mode is engaged.

[AF]: Changes to the auto focus mode. The auto focus mode adjusts the focus automatically. You can also temporarily adjust the focus manually by turning the focus ring.

[MF]: Changes to the manual focus mode. Control the focus ring manually to adjust the focus.

### 3 Turn the focus ring.

The focus value can be set between MF00 (focal distance\*: approximately 10 cm (3.93")) and MF99 (focal distance: infinity). The higher the number the further away the object is to be focused on.

\* Focal distance is the distance to the subject to be focused on.

### NOTE

- Since the auto focus control may not operate properly if there is a flicker, select a shutter speed that is appropriate to the light.
- If you set the unit to auto focus mode at times other than 59.94i (50.00i) and 59.94p (50.00p), the time required for the focus control will be slightly longer than when in normal focus mode.
- In auto mode, it is not possible to switch to the manual focus mode.

## Applications for the USER button

The following functions are available with the USER button assigned to [ONE PUSH AF], or the USER button icon, when manual focus mode is on.

One press AF function	When you press the USER button, or touch the USER button icon, auto focus mode is turned on and automatic focusing occurs at high speed until the camera focuses. <ul style="list-style-type: none"> <li>• The camera returns to manual focus mode when it focuses or after a certain time has elapsed.</li> </ul>
Press AF function	While the USER button is being pressed, or the USER button icon is being touched, the camera temporarily switches to auto focus mode. <ul style="list-style-type: none"> <li>• The focus position is automatically adjusted to suit the subject in the center of the screen.</li> <li>• When [AREA MODE] is set to [FOCUS], [FOCUS/IRIS], or [FOCUS/Y GET] and the area function is used, the focus position is automatically adjusted to suit the subject that was touched. (→ 112)</li> <li>• The function cancels when you release the button and the focus position set while press AF was set is maintained.</li> </ul>

- Refer to page 50 for USER button settings.

## Setting the shutter speed



- A** Shutter speed
  - [A.SHTR] is displayed when the auto shutter mode is on.
- B** SHUTTER

**1** Switch to manual mode with the <AUTO/MANU> switch. (→ 104)

**2** Press the <SHUTTER> button to switch to manual shutter mode.

The shutter speed display is highlighted in orange.

**3** Turn the multial to select the shutter speed.

**4** Press the multial.

The setting changes to the value displayed and exits.

Press the <EXIT> button to exit without changing the setting.

### ■ Adjusting the shutter speed

Shutter speed changes depending on the frame rate of the [REC FORMAT]. (→ 105)

Frame rates	Shutter speed
59.94p/59.94i	1/8↔1/15↔1/30↔1/60↔...1/8000
29.97p	1/8↔1/15↔1/30↔1/50↔...1/8000
50.00p/50.00i/25.00p	1/6↔1/12↔1/25↔1/50↔...1/8000
23.98p	1/6↔1/12↔1/24↔1/48↔...1/8000

- The shutter speed is faster the closer the setting is to 1/8000.

### NOTE

- Brightly shining objects and highly reflective objects may emit light bands into the surroundings.
- The changing of the screen may not look smooth in normal playback.
- When extremely bright subjects are recorded or when recording is performed inside under lights, there may be changes in the color hue and brightness of the screen, with horizontal bands appearing on the screen. Do the following if this occurs:
  - Switch to auto shutter mode.
  - Adjust the shutter speed to 1/50, 1/60, or 1/100.
- When auto iris mode or auto gain mode is enabled, the brightness of the screen may not change even when you adjust the shutter speed. (→ 108, 109)
- When the shutter speed has been set to slow shutter, it may not be possible for the camera to keep up with changes in the images. If this occurs, set the iris, focus, and white balance manually.

## Area mode function

Touch the subject to apply various effects tailored to the subject that is touched.

- Area auto focus function  
Adjusts the focus automatically tailored to the subject that is touched.
- Area auto iris level function  
Adjusts the iris automatically tailored to the subject that is touched.
- Area brightness display  
Displays the luminance level of the subject that is touched.

## Operation function settings

Sets the operation to be assigned to the area mode function from the [CAMERA] menu.

**1** Select the desired function in the [CAMERA] menu → [SW MODE] → [AREA MODE].

- [INHIBIT]: Does not assign a function.
- [FOCUS]: Sets the area auto focus function
- [IRIS]: Area auto iris function
- [Y GET]: Area brightness display
- [FOCUS/IRIS]: Simultaneous operation of the area auto focus function and area auto iris function
- [FOCUS/Y GET]: Simultaneous operation of the area auto focus function and area brightness display



### Operation of area mode function

The function set in the [CAMERA] menu → [SW MODE] → [AREA MODE] can be used by performing the following operation when shooting or while in shooting standby.

**1** Either press the USER button assigned to [AREA] or touch the USER button icon. (→ 50)

- The area frame **A** is displayed, and the **AREA** is displayed on the right side of the screen.
- When the area brightness display is activated, the brightness display in the center does not operate.

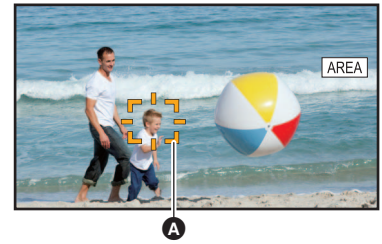

**2** Touch the shooting screen.

- The area frame is displayed in the area that is touched to apply the effects set in the menu.

**3** Press the USER button or the USER button icon\* again.

- The area frame disappears and the unit exits the area mode function.

\* To display the USER button icon, touch and hold the screen.

■ **Adjusting the area size**

**1** Turn the multi-dial to display the [⚙️ AREA].

**2** Press the multi-dial.

**3** Turn the multi-dial to change the size of the area frame.

It changes in 3 stages.

**4** Press the multi-dial.

The setting is changed to the displayed size and exits.

The setting is changed and exits also by pressing the <EXIT> button.



**NOTE**

- The area mode function is cancelled when the power is turned off or when the thumbnail screen is displayed.
- The area mode cannot be used when the digital zoom is enabled.

## Adjusting the white and black balance

To obtain high-quality video at all times using the unit, the white and black balance must be adjusted according to conditions.

Adjust the AWB (white balance adjustment), ABB (black balance adjustment), and AWB (white balance adjustment) in order to obtain higher image quality.

- White balance settings are not possible when IR recording is enabled.
- White balance/black balance adjustment is done using the [AWB] USER button function. Make the settings beforehand. (→ 50)  
It is set in the [USER6] button icon at the time of purchase.

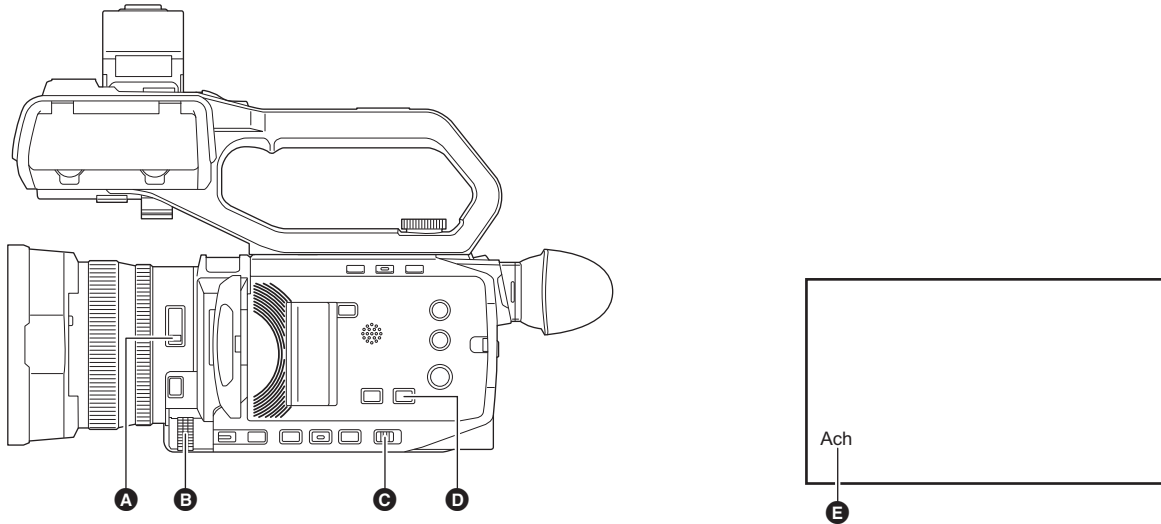

- A** <ND FILTER> switch
- B** Multidial
- C** <AUTO/MANU> switch
- D** <WHITE BAL> button

- E** Color temperature
  - The white balance being set is displayed.

### White balance adjustment

Follow the steps below to adjust the white balance automatically.

#### ■ When stored in white balance [Ach]

- 1 Switch to manual mode with the <AUTO/MANU> switch. (→ 104)**
- 2 Set the gain value. (→ 109)**  
Normally, set this to 0 dB. If it is too dark, set the gain to an appropriate value.
- 3 Press the <WHITE BAL> button to switch to [Ach].**  
Each time you press the button, the white balance switches in the order "Preset", [Ach], [Bch].
- 4 Change the <ND FILTER> switch settings according to the light conditions.**  
For setting examples for the <ND FILTER> switch, refer to "Brightness adjustment". (→ 111)
- 5 Place the white pattern at a point where the light conditions match those for the light source for the subject, and zoom in on the white pattern so that the white color appears in the screen.**
- 6 Adjust the iris (the lens stop).**  
Adjust the iris so that the brightness of Y GET is approx. 70%.
- 7 Either press the USER button assigned to [AWB] or touch the USER button icon.**  
Automatic adjustment of the white balance starts and the white balance adjustment value is memorized.

■ **White pattern**

- A white object (cloth or wall) near the subject may also be used for the white pattern.
- Required size of white pattern is as follows.

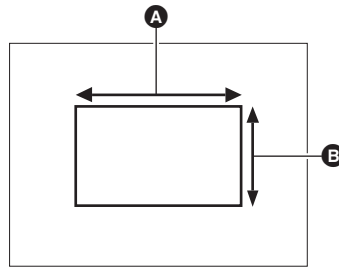

- Ⓐ 1/2 or more of the screen width
- Ⓑ 1/2 or more of the screen height

- Keep bright spotlights out of the screen.
- The white pattern must be placed at the center of the screen.

**NOTE**

- The content previously set is maintained in [Ach] or [Bch]. Make the settings again if the lighting conditions have changed.
- You can make fine adjustments of the color hue for [Ach] and [Bch] using the [RB GAIN CONTROL SETTING]. (→ 69)

■ **Messages displayed in the viewfinder and LCD monitor**

- When the auto tracking white balance (ATW) function is operating, white balance cannot be adjusted.

Status	Message	Remark
During adjustment	[AWB A ACTIVE]	—
Adjustment completed	[AWB A OK]	• The adjusted value is automatically stored in the specified memory (A or B).
When the color temperature of the subject is lower than 2000 K or higher than 15000 K	[AWB NG <COLOR TEMP LOW>] [AWB NG <COLOR TEMP HIGH>]	• [AWB NG <COLOR TEMP LOW>] indicates that the temperature is lower than the displayed temperature. [AWB NG <COLOR TEMP HIGH>] indicates that the temperature is higher than the displayed color temperature.

**When the white balance has not been automatically adjusted**

When the white balance has not been successfully adjusted, an error message is displayed on the viewfinder screen and LCD monitor displays.

Error message	Meaning	Remedy
[AWB NG <LOW LIGHT>]	There is insufficient light.	Increase the amount of light or increase gain.
[AWB NG <LEVEL OVER>]	There is too much light.	Decrease the amount of light or decrease gain.
[AWB NG <COLOR TEMP HIGH>] or [AWB NG <COLOR TEMP LOW>]	The color temperature is too high, or too low.	Use the appropriate filter or light source.

**When having no time to adjust the white balance**

**1 Press the <WHITE BAL> button to switch to “Preset”.**

When switched to “Preset”, the white balance set in [W.BAL PRESET] is displayed. (→ 66)

**2 Either press the USER button assigned to [AWB] or touch the USER button icon to switch the white balance.**

[P 3200K], [P 5600K], and “VAR” (the value set in the [CAMERA] menu → [SW MODE] → [W.BAL VAR]) change in order.

- When “VAR” is selected, turning the multidial can set any white balance value between [V 2000K] and [V 15000K].

### Setting the variable value for the white balance

The color temperature of white balance can be adjusted by the setting menu.

- 1 Press the <WHITE BAL> button to switch to “Preset”.
- 2 Either press the USER button assigned to [AWB] or touch the USER button icon to switch to “VAR”.
- 3 In the [CAMERA] menu → [SW MODE] → [W.BAL VAR], set the color temperature.

This can be set from [2000K] to [15000K].

#### ■ Setting with the multi manual function

- 1 Press the <WHITE BAL> button to switch to “Preset”.
- 2 Either press the USER button assigned to [AWB] or touch the USER button icon to switch to “VAR”.

The white balance display is highlighted in orange.

- 3 Turn the multial to select the color temperature.
- 4 Press the multial.

The setting changes to the value displayed and exits.

Press the <EXIT> button to exit without changing the setting.

#### NOTE

- The “VAR” value displayed on the camera image screen is not guaranteed to be an absolute value. Use it for reference purposes only.

### Settings of the auto tracking white balance (ATW) function

The unit is equipped with the Auto Tracking White Balance (ATW) function that automatically tracks the white balance of images according to the lighting conditions.

The auto tracking white balance function can be assigned to each of [Ach], [Bch], and “Preset” in white balance.

Set the function with the [CAMERA] menu → [SW MODE] → [ATW].

#### ■ Applications for the USER button

[ATW]	Switches enable/disable of the ATW function.
[ATW LOCK]	Locks the white balance value adjusted with the ATW function. This is enabled when the white balance setting is [ATW].

- Refer to page 50 for USER button settings.

#### NOTE

- [ATW] is displayed on the camera image screen when the ATW function is enabled.
- [LOCK] is displayed on the camera image screen when the [ATW LOCK] function is enabled.
- The [AWB] USER button is disabled when the ATW function is enabled.
- By adjusting [ATW TARGET R] and [ATW TARGET B] individually, you can set ATW to suit the recording conditions. (→ 66)
- This function does not guarantee 100% accuracy for the white balance. Note that the tracking performance relative to changes in ambient lighting and white balance performance has been given a certain degree of latitude.

### Canceling the auto tracking white balance

Switch white balance by pressing the USER button assigned to the [ATW] again, touching the USER button icon again, or pressing the <WHITE BAL> button. However, with white balance set in [CAMERA] menu → [SW MODE] → [ATW], it is not canceled by pressing the USER button.

### Viewfinder and LCD monitor screen displays relating to white balance

For details, refer to “Screen status display”. (→ 159)

## Black balance adjustment

Black balance must be adjusted in the following instances:

- When the unit is used for the first time
- When used after a long period of time without use
- When the ambient temperature has changed considerably
- When super gain is set with the USER button
- When changing the gain values
- When switching items in the [SYSTEM] menu → [REC FORMAT].

To shoot optimum video, we recommend adjusting the black balance immediately before shooting.

Before adjusting the black balance, prepare the conditions for adjusting the white balance.

**1** Switch to manual mode with the <AUTO/MANU> switch. (→ 104)

**2** Press the <WHITE BAL> button to switch to [Ach] or [Bch].

Each time you press the button, the white balance switches in the order “Preset”, [Ach], [Bch].

**3** Either press and hold the USER button assigned to [AWB] for approximately 2 seconds or touch and hold the USER button icon for approximately 2 seconds.

After adjustment of the black balance, white balance is then adjusted, and the black balance/white balance adjustment values are memorized.

If white balance has been set elsewhere other than in [Ach] and [Bch], then only the black balance is adjusted.

### ■ Messages displayed in the viewfinder and LCD monitor

Status	Message	Remark
During adjustment	[ABB ACTIVE]	—
Adjustment completed	[ABB OK]	• The adjusted value is automatically stored in the specified memory (A or B).

### NOTE

- The content previously set is maintained in [Ach] or [Bch]. Make the settings again if the lighting conditions have changed.
- During black balance adjustment, the aperture is set to automatically shut out light.
- During recording, black balance cannot be adjusted.
- Video is not recorded to the memory card even if the REC button is pressed while executing the automatic black balance.
- While adjusting the black balance, the gain circuitry in the device automatically switches to perform adjustments. Flicker or noise sometimes appears on the viewfinder screen and LCD monitor. This is not a malfunction.

## Black balance memory

Values stored to memory are saved even if the unit is turned off.

## Using the zoom function

Adjust the angle of view you want to shoot.

The unit has a 24× optical zoom.

This can be expanded up to approximately 48 times (approximately 32 times in UHD recording) when the [CAMERA] menu → [SW MODE] → [i.ZOOM] → [ON] is set.

### Adjusting the zoom position

The zoom can be operated at the following 3 locations:

- Zoom lever (on the grip)
- Zoom lever (on the handle): When the handle unit (X2000) supplied, (X1500) optional) is attached to the unit
- Rear ring on the lens: When [CAMERA] menu → [SW MODE] → [REAR RING] → [ZOOM] is selected

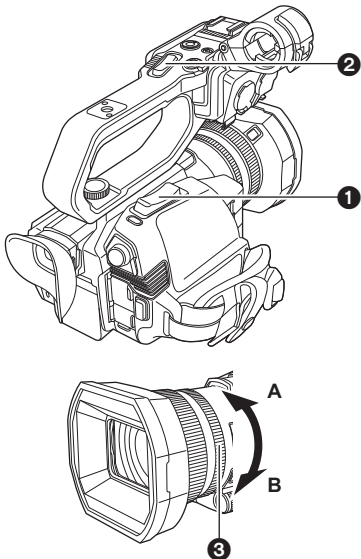

- 1 Zoom lever (on the grip/
- 2 Zoom lever (on the handle)

<T>: Zoom in the image.

<W>: Zoom out the image.

- 3 Rear ring

**A side:** Zoom out the image.

**B side:** Zoom in the image.

- In the [ZOOM RING] menu, you can also change the turn direction for the rear ring and change the zoom control. (→ 65)



- A Zoom ratio

- The zoom ratio can be confirmed between [Z00]/[iZ00] (maximum wide angle) to [Z99]/[iZ99] (maximum telephoto) on the screen display. The value becomes higher as the unit zooms in and smaller as the unit zooms out.

#### ■ About the zoom speed

- The zoom speed changes with the amount that the zoom lever (on the grip) is pushed or the speed that the rear ring is turned.
- The zoom is at a steady rate with the zoom lever (on the handle).  
Performs the zoom operation with the speed set in the [CAMERA] menu → [SW MODE] → [H.ZOOM SPEED].

#### NOTE

- If you take your finger off the zoom lever during zoom operation, the operation sound may be recorded. When returning the zoom lever to the original position, move it quietly.
- When the zoom magnification is at its maximum, the subjects are focused at about 1.2 m (47.2") or more.
- When the zoom ratio is 1×, the subjects are focused at about 10 cm (3.93") or more.
- The units for the zoom ratio can be changed in the [ZOOM/FOCUS] menu. (→ 80)

### Using i.ZOOM

When [i.ZOOM] is set to [ON], you can zoom to a maximum of approximately 48× (32× when recording with UHD) while maintaining the beauty of high-definition image quality.

#### 1 Select the [CAMERA] menu → [SW MODE] → [i.ZOOM] → [ON].

- You can set [i.ZOOM] in a USER button so that you can use iZoom. (→ 50)
- The zoom ratio display changes.  
(For example)
  - iZ00 to iZ99: Optical zoom range
  - [i]Z99: In iZoom

#### NOTE

- In the following case, [i.ZOOM] is fixed to [OFF]:
  - When super slow recording is enabled

### Using fast zoom

When [FAST ZOOM] is assigned to a USER button, you can use fast zoom by operating the zoom lever (on the grip).

- 1** Select the [CAMERA] menu → [USER SW] → [USER1] to [USER12] → [FAST ZOOM].
- 2** Either press the USER button assigned to [FAST ZOOM] or touch the USER button icon.
- 3** Push the zoom lever (on the grip) until the end to zoom.
  - The zoom ratio display changes during fast zoom. (For example: 99)

#### NOTE

- When the [CAMERA] menu → [SW MODE] → [H.ZOOM SPEED] is set to [7], fast zoom can also be used by operating the zoom lever (on the handle).
- As the operating noise of fast zoom will be louder than normal, the operating noise may be recorded during recording. If the operating noise is a problem, disable [FAST ZOOM].
- Auto focus may not be able to keep up during fast zoom, depending on the subject.
- Fast zoom cannot be used in the following case:
  - When interval recording is enabled

## Using the built-in LED light

By attaching the handle unit ( **X2000** supplied, **X1500** optional), you can use the built-in LED light to brighten even dark places for recording.

### 1 Slide the <LIGHT> switch to turn on/off the built-in LED light.

ON: Light is on

OFF: Light is off

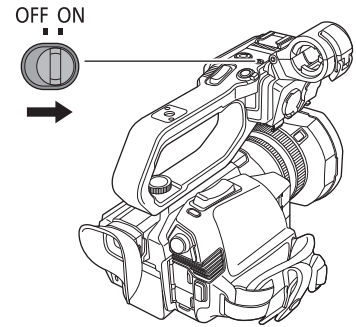

## Adjust the amount of light from the built-in LED light

### 1 Turn the light dimmer dial.

Turn to <+> to brighten, turn to <-> to dim.

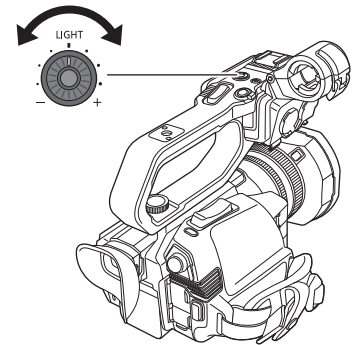

### **NOTE**

- While the built-in LED light is turned on, do not look directly into the lighting part or get it near people's eyes.
- Using the built-in LED light shortens the time for recording with the battery.
- When the built-in LED light is turned on, or the brightness of the built-in LED light is changed with the light dimmer dial, depending on the shooting conditions, the auto tracking white balance function may not work correctly. Adjust the white balance. (→ 114)
- When the remaining battery level gets low, the built-in LED light may turn off. It also may not turn on.
- If you operate the light dimmer dial during recording, operating noise may be recorded.



## Image quality adjustment

The image quality of the video to record can be set in the [SCENE FILE] menu. Measurement equipment such as a vector scope is necessary to change “Advanced settings”.

### Detail function

This function thickens or weakens the outlines of images. It effectively softens or sharpens images, but in some cases, the whole image may become rough due to emphasized noise and edges. To avoid such problems, it is necessary not to add this effect on parts where emphasizing is not needed and keep the details of the parts.

#### ■ General settings

[MASTER DTL]: Sets the level of the detail effect as a whole.

[DTL CORING]: Sets the level of signal (including noise) so that the detail effect does not activate.

#### ■ Advanced settings

[V.DTL LEVEL]: Sets the intensity of the detail level in the vertical direction.

### Skin tone function

This function makes human skin look smoother in images.

#### ■ General settings

[SKIN TONE DTL.]

#### ■ Advanced settings

There are no setting items.

### RB gain control function

This is a function that adds or reduces the intensities of reds and blues when the white balance setting is [Ach] or [Bch]. It works when auto white balance is enabled.

- It does not work when the white balance setting is [ATW], [P 3200K], [P 5600K], or “VAR”.

#### ■ General settings

Use the unit with the factory settings.

#### ■ Advanced settings

Set with the [SCENE FILE] menu → [RB GAIN CONTROL SETTING].

- When the white balance setting is [Ach]

[R GAIN AWB A]: Sets to add or reduce the intensity of the red color.

[B GAIN AWB A]: Sets to add or reduce the intensity of the blue color.

- When the white balance setting is [Bch]

[R GAIN AWB B]: Sets to add or reduce the intensity of the red color.

[B GAIN AWB B]: Sets to add or reduce the intensity of the blue color.

- When the white balance setting is [Ach] and auto white balance is performed

[AWB A GAIN OFFSET]: Sets whether to keep or reset the values set for [R GAIN AWB A] and [B GAIN AWB A].

- When the white balance setting is [Bch] and auto white balance is performed

[AWB B GAIN OFFSET]: Sets whether to keep or reset the values set for [R GAIN AWB B] and [B GAIN AWB B].

### Chroma setting function

This function sets color saturation and phase. It applies effects on whole images. It cannot be set to individual color hue.

#### ■ General settings

[CHROMA LEVEL]: Sets the chroma level of the  $P_R$  signal and  $P_B$  signal. When the vector scope is used, the distance from the center (no color) is increased or decreased for the entire image.

[CHROMA PHASE]: Finely adjusts the chroma phase of the  $P_R$  signal and  $P_B$  signal. When the vector scope is used, the whole image rotates clockwise or counter-clockwise.

#### ■ Advanced settings

No setting items are provided.

### Matrix function

This function sets the image color representation by selecting the matrix table.

#### ■ General settings

[MATRIX]

#### ■ Advanced settings

There are no setting items.

## Color correction function

This function sets color saturation and phase. Each of the 16 divisions of color hue can be set individually.

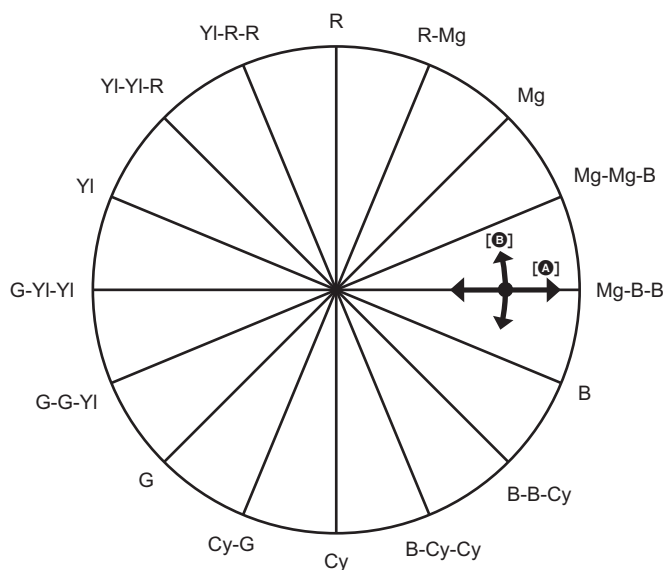

- Ⓐ [SAT]
- Ⓑ [PHASE]

### ■ General settings

Use the unit with the factory settings.

### ■ Advanced settings

[R]/[R-Mg]/[Mg]/[Mg-Mg-B]/[Mg-B-B]/[B]/[B-B-Cy]/[B-Cy-Cy]/[Cy]/[Cy-G]/[G]/[G-G-Yl]/[G-Yl-Yl]/[Yl]/[Yl-Yl-R]/[Yl-R-R]:

Changes the phase and saturation. When setting the phase, + is clockwise and – is counter-clockwise.

## Black control function

This function sets the black level that is to be the reference of luminance.

### ■ General settings

[MASTER PED]: Sets the reference black level. RGB also changes by changing this setting. – makes the black color darker, and + makes it less dark.

### ■ Advanced settings

There are no setting items.

## Gamma function

This function optimizes the tone of images.

### ■ General settings

[GAMMA MODE SEL]: Selects a gamma mode from 8 types.

### ■ Advanced settings

[BLACK GAMMA]: Sets the gamma curve compression and expansion of dark areas.

## Knee function

This function sets the compression of video signals to prevent halation in images.

### ■ General settings

Use the unit with the factory settings.

### ■ Advanced settings

[KNEE MODE]: Sets the operation mode of knee function ([AUTO]/[LOW]/[MID]/[HIGH]/[OFF]).

## White clip function

Sets so that the brightest parts of the video signal cannot exceed a certain level.

### ■ General settings

Use the unit with the factory settings.

### ■ Advanced settings

Set with the [SCENE FILE] menu → [WHITE CLIP SETTING].

[WHITE CLIP]: Switches the white clip function [ON]/[OFF]. The [WHITE CLIP LEVEL] setting value is enabled when [ON].

[WHITE CLIP LEVEL]: Sets the white clip level.

## Flash band compensation (FBC) function

This compensates for the phenomena of light and dark bands (flash bands) that horizontally divide images recorded in environments where there are flashes from other cameras, and reduces their effect.

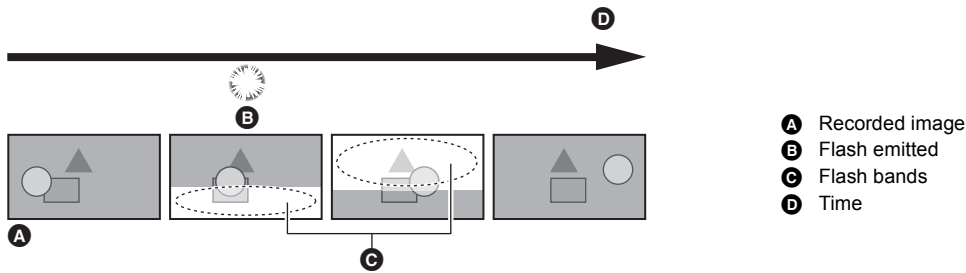

### Flash band compensation function settings

You allocate the flash band compensation function to a USER button to use it.

For details, refer to “Assigning function to the USER buttons”. (→ 50)

[FBC] is displayed on the camera image screen when the flash band compensation function is enabled.

### When using the flash band compensation function

The flash band compensation function works whenever the brightness in the lower part of the screen changes greatly, irrespective of the presence of flashes. For example, the flash band compensation function may operate under some recording environments, such as when zooming in or out on a bright window. It is recommended to use the function in recording environments where flashes are anticipated.

Note that due to the recording environment, even when there are flashes, you may not get sufficient results from the flash band compensation function.

#### NOTE

- The following phenomena may occur when there are flashes. These are due to the flash band compensation function, and do not indicate a malfunction.
  - Moving subjects appear to stop momentarily
  - Resolution drops when there are flashes
  - Horizontal lines are visible when there are flashes
- In the following cases, this cannot be set.
  - In auto mode
  - When the frame rate of the [REC FORMAT] is 29.97p, 23.98p, or 25.00p
  - When recording with super slow
- The shutter speed is set to 1/60 or 1/50. The shutter speed cannot be adjusted.

## Super slow recording function

It is possible to acquire smooth slow motion video by shooting with a different frame rate from the frame rate to play back. This allows high-speed shooting of 120 fps/100 fps.

### 1 In [SYSTEM] menu → [FREQUENCY]/[FILE FORMAT]/[REC FORMAT], select the resolution, codec, and base frame rate for recording images.

- Select the following items.

[FREQUENCY]	[FILE FORMAT]	[REC FORMAT]
[59.94Hz]	[MOV]	[1080-59.94p/422LongGOP 100M] [1080-29.97p/422LongGOP 50M] [1080-23.98p/422LongGOP 50M]
[50.00Hz]		[1080-50.00p/422LongGOP 100M] [1080-25.00p/422LongGOP 50M]

### 2 Select the [SYSTEM] menu → [SUPER SLOW] → [ON].

- This can also be set even with the USER button.  
Refer to “Assigning function to the USER buttons”. (→ 50)

### 3 Press the REC button.

Super slow recording starts.

#### ■ Frame rate and effect

The slow motion effect during playback changes depending on the frame rate of the [REC FORMAT].

Frame rate of [REC FORMAT]	Slow motion effect during playback
59.94p, 50.00p	1/2 speed
29.97p, 25.00p	1/4 speed
23.98p	1/5 speed

#### NOTE

- Super slow recording is not possible with any combination apart from the [FILE FORMAT] and [REC FORMAT] combinations shown in Step 1.
- Audio cannot be recorded with the super slow recording.
- The [CAMERA] menu → [SW MODE] → [AF SPEED] is fixed to [NORMAL].
- The [RECORDING] menu → [TC/UB] → [FREE/REC RUN] is fixed to [REC RUN].
- The following functions are canceled.
  - Dynamic range stretcher function (→ 139)
  - Flash band compensation function (→ 123)
  - [i.ZOOM] (→ 118)
  - Digital zoom function (→ 141)
  - Pre-recording (→ 129)
  - [2 SLOTS FUNC.] (→ 129 to 131)
  - Interval recording (→ 132)
  - [HYBRID O.I.S.] (→ 139)
- In the following case, this cannot be set.
  - When using the face detection/tracking AE&AF function
- (When [FREQUENCY] is set to [59.94Hz])  
There is a slight gap between the displayed frame rate for Super Slow Recording and the actual frame rate at which Super Slow Recording is performed. Although [S.SLOW120] is displayed on the screen, the actual recording is performed at 119.88 fps.
- It is not possible to adjust the shutter speed to a value slower than the limit imposed by the frame rate used for Super Slow Recording.  
(Example) When [FREQUENCY] is set to [59.94Hz], the shutter speed cannot be adjusted to a value smaller than 1/120.
- It may take time to stop recording even if recording is stopped right after recording is started.
- When [SUPER SLOW] is [ON], the unit will restart after the following operation.
  - When [FILE FORMAT] or [REC FORMAT] is changed to any item other than described in Step 1
- The recording is paused when 10 hours has past from the time the recording was started. The recording is automatically resumed after few seconds. With super slow recording, the recording time becomes less than 10 hours depending on the frame rate of the [REC FORMAT].

Frame rate of [REC FORMAT]	Continuous recordable time for 1 clip
59.94p, 50.00p	5 h
29.97p, 25.00p	2 h 30 min
23.98p	2 h

- “h” is an abbreviation for hour and “min” for minute.
- For information about recording functions that cannot be used simultaneously, refer to page 192.

## Audio input

The unit can record 2 channels of audio.

When the handle unit ( **X2000** supplied, **X1500** optional) is attached to the unit, you can connect audio equipment or an external microphone to the <INPUT 1>/<INPUT 2> terminals.

The audio to input to each channel can be switched to the built-in microphone, an external microphone, or a connected audio device.

### Switching the audio input

#### ■ Audio recording format

The audio recording format such as compression format varies depending on the [FILE FORMAT].

[FILE FORMAT]	Recording format	Sampling rate/bit
[MOV]	Linear PCM (LPCM)	48 kHz/24 bit
[MP4]	AAC	48 kHz/16 bit
[AVCHD]	Dolby Audio™	48 kHz/16 bit

#### ■ Selecting audio input signals (When the handle unit is attached to the unit)

Selects the audio signal to record in the audio channel 1/audio channel 2.

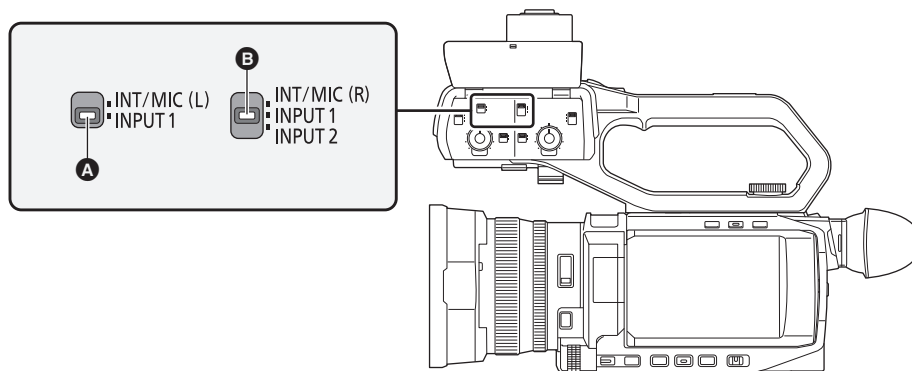

- A** CH1 SELECT switch
- B** CH2 SELECT switch

CH1 SELECT switch setting	CH2 SELECT switch setting	Input signal to be recorded	
		Audio channel 1	Audio channel 2
<INT/MIC (L)>	<INT/MIC (R)>	Built-in microphone <L>/<MIC> terminal Lch	Built-in microphone <R>/<MIC> terminal Rch
	<INPUT1>	Built-in microphone <L>/<MIC> terminal Lch	<INPUT 1> terminal
	<INPUT2>	Built-in microphone <L>/<MIC> terminal Lch	<INPUT 2> terminal
<INPUT1>	<INT/MIC (R)>	<INPUT 1> terminal	Built-in microphone <R>/<MIC> terminal Rch
	<INPUT1>	<INPUT 1> terminal	<INPUT 1> terminal
	<INPUT2>	<INPUT 1> terminal	<INPUT 2> terminal

### Using the built-in microphone/external microphone (stereo mini jack)

When an external microphone (stereo mini jack) is connected to the <MIC> terminal, audio switches from the built-in microphone to the audio input of the external microphone connected to the <MIC> terminal.

#### ■ When the handle unit is attached to the unit

Make the following settings to switch to audio input from the built-in microphone or external microphone (stereo mini jack).

#### 1 Set the CH1 SELECT switch to the <INT/MIC (L)> position.

The audio signals from <L> of the built-in microphone or the Lch of the external microphone connected to the <MIC> terminal are recorded to audio channel 1.

#### 2 Set the CH2 SELECT switch to the <INT/MIC (R)> position.

The audio signals from <R> of the built-in microphone or the Rch of the external microphone connected to the <MIC> terminal are recorded to audio channel 2.

#### NOTE

- To decrease the wind noise of the microphone, select the [AUDIO] menu → [INPUT SETTINGS] → [CH1 MIC LOWCUT]/[CH2 MIC LOWCUT] → [ON].

## Using audio equipment/external microphone (XLR, 3-pin)

- 1 Attach the handle unit to the unit.
- 2 Connect an audio device or an external microphone to the <INPUT 1>/<INPUT 2> terminal.
- 3 Switch the connected audio input with the <INPUT1>/<INPUT2> switch.

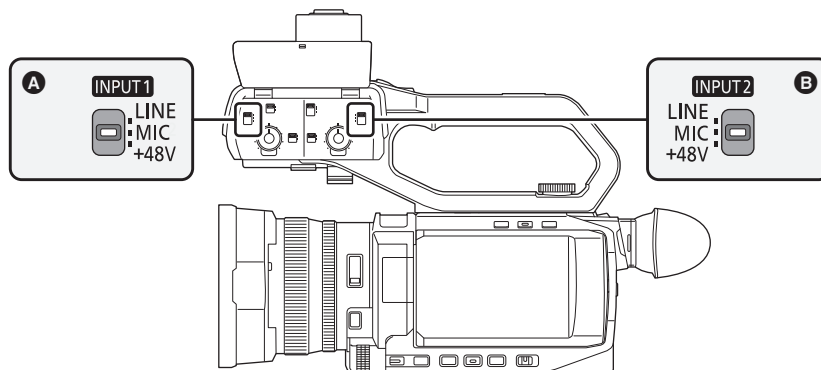

- A <INPUT1> switch
- B <INPUT2> switch

Connected device	<INPUT1>/<INPUT2> switch setting	Menu settings (you can set each channel individually)	
		[INPUT1 MIC LEVEL]/ [INPUT2 MIC LEVEL] <sup>*1</sup>	[INPUT1 LINE LEVEL]/ [INPUT2 LINE LEVEL] <sup>*2</sup>
Audio device	<LINE>	Disabled	[4dB], [0dB]
External microphone	<MIC>	[-40dB], [-50dB], [-60dB]	Disabled
External microphone (with power supply)	<+48V>	[-40dB], [-50dB], [-60dB]	Disabled

\*1 Factory setting: [-50dB]

\*2 Factory setting: [0dB]

### NOTE

- When using a Unidirectional microphone AG-MC200G (optional), set [INPUT1 MIC LEVEL]/[INPUT2 MIC LEVEL] to [-50dB].
- When the handle unit is detached, audio input switches to the built-in microphone/external microphone (stereo mini jack).
- After detaching the external microphone (XLR, 3-pin), switch the CH1 SELECT/CH2 SELECT switch to <INT/MIC (L)> or <INT/MIC (R)> to set the input signal to the built-in microphone. No audio will be recorded if you continue to record as is.
- **When connecting equipment that does not support +48 V power supply, set the <INPUT1>/<INPUT2> switch to <LINE> or <MIC>. If set to <+48V>, this unit or the connected equipment may malfunction.**
- If an abnormality occurs with the +48 V power supply, the power of this unit will turn off.
- Using a phantom microphone shortens the battery time.
- When noise from unconnected terminals is bothersome, set the <INPUT1>/<INPUT2> switch to <LINE>.

## Adjusting the audio recording level

There are manual adjustment and automatic adjustment as the adjustment method of the audio recording level.

- Audio channel can be individually set.

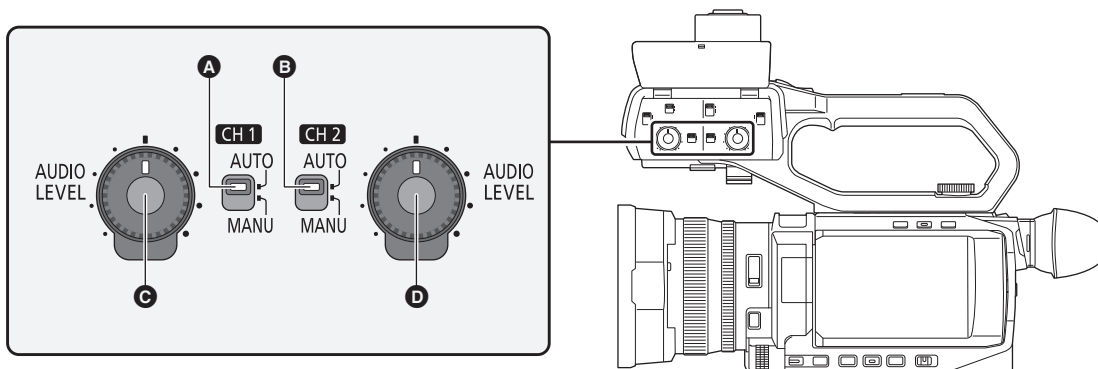

- A <CH1> switch
- B <CH2> switch
- C <AUDIO LEVEL CH1> dial
- D <AUDIO LEVEL CH2> dial

### Automatic adjustment of the recording level

#### ■ When the handle unit is attached to the unit

##### 1 Switch the <CH1>/<CH2> switch to <AUTO>.

- The following settings are disabled when the <CH1>/<CH2> switch is switched to <AUTO>.
  - Recording level adjustments with the <AUDIO LEVEL CH1>/<AUDIO LEVEL CH2> dial

#### ■ When the handle unit has not been attached to the unit

##### 1 Select the [AUDIO] menu → [MIC SETTING] → [CH1 LEVEL]/[CH2 LEVEL] → [AUTO].

- Following settings are disabled when the [AUDIO] menu → [MIC SETTING] → [CH1 LEVEL]/[CH2 LEVEL] → [AUTO] is selected.
  - [AUDIO] menu → [MIC SETTING] → [CH1 LEVEL CONTROL]/[CH2 LEVEL CONTROL] setting

### Manual adjustment of the recording level

#### ■ When the handle unit is attached to this unit

##### 1 Switch the <CH1>/<CH2> switch to <MANU>.

##### 2 Adjust the recording level with <AUDIO LEVEL CH1>/<AUDIO LEVEL CH2> dial.

#### ■ When the handle unit has not been attached to this unit

##### 1 Select the [AUDIO] menu → [MIC SETTING] → [CH1 LEVEL]/[CH2 LEVEL] → [MANUAL].

##### 2 Adjust the recording level with [AUDIO] menu → [MIC SETTING] → [CH1 LEVEL CONTROL]/[CH2 LEVEL CONTROL].

- The level increases as the number increases.
- Audio is not recorded when set to [MUTE].

#### NOTE

- When the input level of audio exceeds 0 dB, the level display exceeding 0 dB is displayed in red in the camera image screen and the audio level meter in the AUDIO screen of the mode check. This is indicating that the input volume is too high.

Adjust so that the maximum value of the audio level does not exceed 0 dB.

#### A Audio level meter

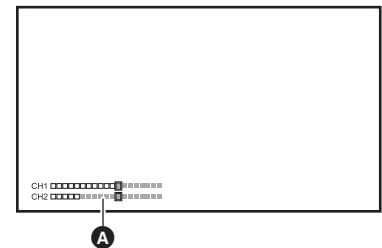

- To enable the settings in [AUDIO] menu → [INPUT SETTINGS] → [CH1 LIMITER]/[CH2 LIMITER], make the following settings.
  - (When the handle unit is attached to the unit)
    - Switch the <CH1>/<CH2> switch to <MANU>
  - (When the handle unit has not been attached to the unit)
    - Select [AUDIO] menu → [MIC SETTING] → [CH1 LEVEL]/[CH2 LEVEL] → [MANUAL]

### Confirming the audio input level

The input level of the audio can be confirmed in the camera image screen and the AUDIO screen of the mode check.

## Monitoring the audio

Audio recorded with the unit can be heard with a speaker or headphones.  
Audio is not output from the speaker during shooting.

## Setting the output audio

Sets the audio channel and the format to be output from the headphone terminal.

**1** Select the [AUDIO] menu → [OUTPUT SETTINGS] → [AUDIO OUT].

**2** Select the type of audio.

[CH1]: Outputs the signal for audio channel 1 as monaural.

[CH2]: Outputs the signal for audio channel 2 as monaural.

[CH1/2 STEREO]: Outputs the signals of the audio channel 1 and the audio channel 2 as stereo.

[CH1/2 MIX]: Mixes the signals of the audio channel 1 and the audio channel 2 and outputs as monaural.

### NOTE

- Adjust the volume of the headphones and built-in speaker as follows.
  - During recording, volume is adjusted with the [  AUDIO MON] multi manual function. (→ 144)
  - During playback, volume is adjusted with the zoom lever (on the grip). (→ 153)

## Confirming audio input setting

The setting for the audio input can be confirmed in the AUDIO screen of the mode check.  
For details, refer to “Mode check display” (→ 165).



## Special recording function

Special recording such as pre-recording or relay recording is possible by setting the menu.

### Pre-recording

Records the video and audio from specific time before the operation to start the recording.

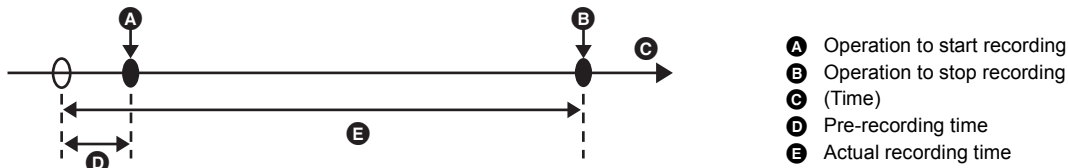

The pre-recording time varies depending on the setting of the [SYSTEM] menu → [FILE FORMAT]/[REC FORMAT].

Pre-recording time	[FILE FORMAT]	[REC FORMAT]
Approx. 5 seconds	[MOV], [MP4]	UHD recording format
Approx. 10 seconds	[MOV], [MP4]	FHD recording format
	[AVCHD]	All

#### 1 Select the [RECORDING] menu → [PRE REC] → [ON].

[P] is displayed in the recording status display of the camera image screen.

- You can also either press the USER button assigned to [PRE REC] or touch the USER button icon to switch enable/disable of [PRE REC].

#### 2 Press the REC button.

#### NOTE

- Aim the unit at the subject beforehand.
- The video and audio may not be able to record for specific time before in following cases.
  - Immediately after turning on the power
  - Immediately after opening the menu
  - Immediately after the memory card is inserted
  - Immediately after playing back the recorded video
  - Immediately after closing the thumbnail screen
  - During the time from recording stop until completion of writing to the memory card
- When [PRE REC] is set to [ON], the [RECORDING] menu → [TC/UB] → [FREE/REC RUN] is fixed to [FREE RUN].
- The pre-recording is canceled once when 3 hours has past without starting the recording.
- Pre-recording cannot be performed if the remaining recording capacity of the memory card is less than 1 minute.
- Pre-recording cannot be used in the following cases:
  - When super slow recording is enabled
  - When background recording is enabled
  - When interval recording is enabled
- For information about recording functions that cannot be used simultaneously, refer to page 192.

### Relay recording

When inserting memory cards into the 2 card slots, recording can continue on the second memory card if the remaining recording capacity of the other memory card is exhausted.

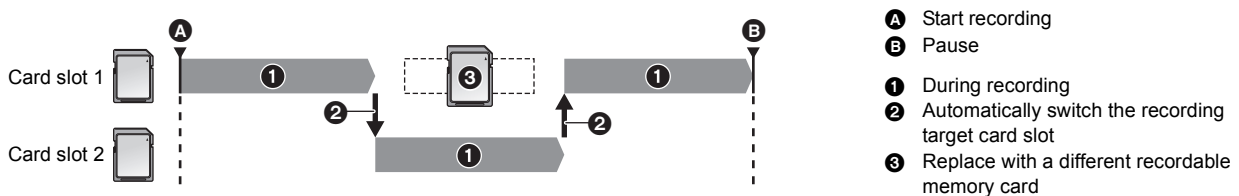

#### 1 Select the [RECORDING] menu → [2 SLOTS FUNC.] → [RELAY REC].

[RELAY] is displayed in the 2 slot function display of the camera image screen.

A slanted line is displayed on the [RELAY] display when the relay recording is not possible, such as when a memory card is not inserted in either of the 2 card slots.

## 2 Press the REC button.

- The recording target switches to another memory card when the remaining recording capacity of one of the memory cards is exhausted during recording and relay recording starts. The number of the card slot that became the recording target is displayed with black and white inverted. Recording can be performed on 3 or more memory cards. Replace the memory card with no more remaining recording capacity after the recording target has switched.
- To change the recording target card slot before starting the recording, press the <SLOT SEL> button. This will not operate during recording.

### NOTE

- It may take some time to recognize the memory card when the memory card is inserted. When recording to 3 or more memory cards by replacing a memory card while recording, replace the memory card with recording capacity sufficiently left on the memory card that is recording.
- The recording target cannot be switched when the remaining recording capacity of the relay memory card is less than 1 minute.
- After relay recording, a message about the remaining card capacity is displayed. Replace the memory card that has run out of capacity.
- The maximum continuous recording time for relay recording is 10 hours.
- The recording is stopped once when the recording time of relay recording exceeds 10 hours. The recording is automatically resumed after few seconds.
- For information about recording functions that cannot be used simultaneously, refer to page 192.

## Simultaneous recording

Insert memory cards into 2 card slots to record the same video onto 2 memory cards.

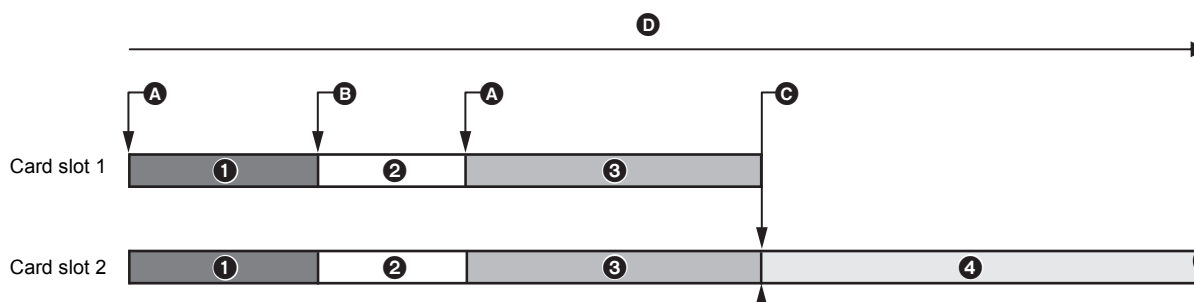

- A** Start recording
- B** End recording
- C** End recording (no remaining space)
- D** Memory card recording time

- 1** A clip
- 2** Stand-by
- 3** B clip
- 4** C clip

## 1 Select the [RECORDING] menu → [2 SLOTS FUNC.] → [SIMUL REC].

[SIMUL] is displayed in the 2 slot function display of the camera image screen.

A slanted line is displayed on the [SIMUL] display when simultaneous recording is not possible, such as when a memory card is not inserted in either of the 2 card slots.

## 2 Press the REC button.

- The simultaneous recording will stop when the remaining recording capacity of one of the memory cards is exhausted. A slanted line is displayed in the [SIMUL] display when simultaneous recording is not possible. To start the simultaneous recording again, replace the memory card that has run out of the recording capacity with another memory card, and then press the REC button.
- When the REC button is pressed without replacing the memory card, standard recording is performed to the memory card with remaining recording capacity.

### NOTE

- Use of memory cards with the same Speed Class or capacity for simultaneous recording is recommended. The recording may stop due to insufficient speed when memory cards with different Speed Classes or capacities are used. If the recording is stopped, the video right before stopping may become invalid recording.
- Start the recording after both of the 2 memory cards have been recognized. When the recording starts before both memory cards are recognized, the unit performs standard recording on one of the memory cards that has been recognized. The unit confirms the status of the memory card every time the recording is completed. If both cards are recognized at that time, it will perform the simultaneous recording from the next recording.
- When recording to one of the memory cards stops due to a recording error during simultaneous recording, recording to the other memory card continues.
- If there is remaining recording capacity on one of the memory cards after completing the simultaneous recording, the memory card with remaining recording capacity automatically becomes the recording target. Standard recording will start when the REC button is pressed.
- Standard recording is performed when only one memory card is inserted even if the unit is set to simultaneous recording.
- Once the simultaneous recording is completed, [DEL LAST CLIP] assigned to the USER button will not operate.
- For the folder name and the file name when performing simultaneous recording in MOV format/MP4 format, refer to "Handling the recording data" (→ 44).
- For information about recording functions that cannot be used simultaneously, refer to page 192.

## Background recording

If the memory cards are inserted into 2 card slots, set the background recording mode and then press the REC button to start recording simultaneously on card slot 1 and card slot 2. On card slot 1, recording can be repeatedly started and stopped as necessary by operating the REC button. On card slot 2, the recording operation continues as background recording.

By performing background recording on card slot 2, you will not miss important scenes while recording is stopped.

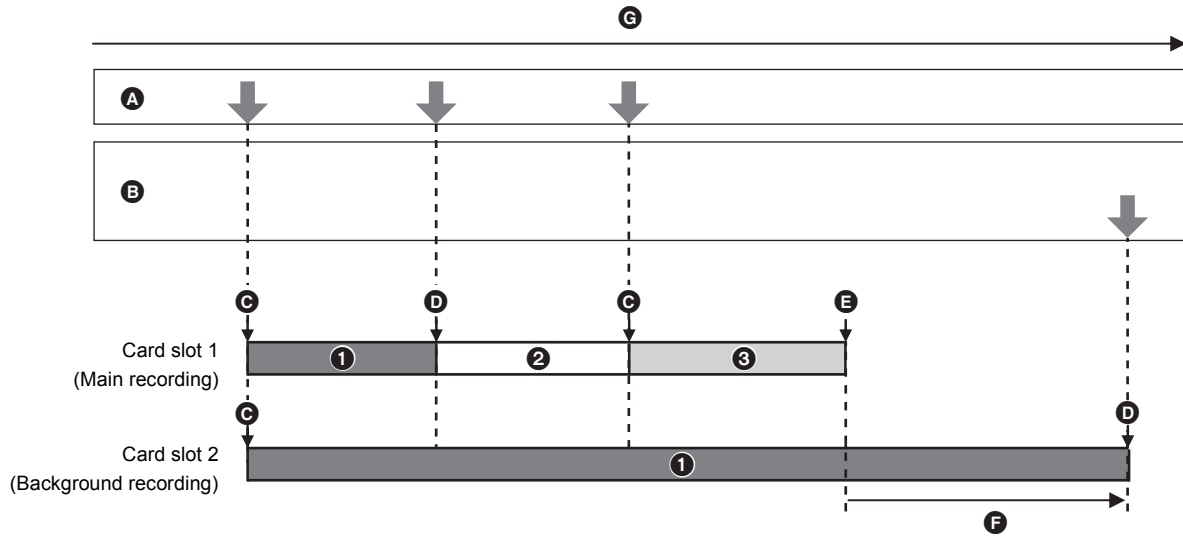

- A** REC button operations
- B** Button operation for background recording stop\*
- C** REC
- D** REC PAUSE
- E** REC STOP (No remaining space on card slot 1 )
- F** Continues recording to card slot 2
- G** Memory card recording time

- 1** A clip
- 2** Stand-by
- 3** B clip

\* USER button assigned to [BACKGR PAUSE]

### Starting background recording

**1** Select the [SYSTEM] menu → [FILE FORMAT] → [MOV].

**2** Select the [RECORDING] menu → [2 SLOTS FUNC.] → [BACKGR REC].

[BACKGR] is displayed in the 2 slot function display of the camera image screen.

A slanted line is displayed on the [BACKGR] display when background recording is not possible, such as when a memory card is not inserted in the card slot 2.

**3** Press the REC button.

Recording starts simultaneously on card slot 1 and card slot 2.

Start or stop recording on card slot 1 with REC button operations.

On card slot 2, the recording operation continues as background recording.

#### NOTE

- Records on both card slot 1 and card slot 2 in the format set in the [SYSTEM] menu.
- Background recording cannot be performed in the following cases.
  - When [RECORDING] menu → [REC FUNCTION] → [REC MODE] is set to [INTERVAL]
  - When [SYSTEM] menu → [FILE FORMAT] is set to other than [MOV]
  - When [SYSTEM] menu → [REC FORMAT] is UHD
- The lighting status of the tally lamp\*1 changes according to start or stop of recording on card slot 1.
- Time code is fixed to free run.
- Control of recording operation of the external equipment (such as recorder) connected to the <SDI OUT> terminal\*2 and the <HDMI> terminal is linked to the start/stop recording of the card slot 1.
- In the background recording mode, the USER button assigned to [DEL LAST CLIP] does not work.
- The memory card in card slot 1 can be replaced even while background recording is performed on card slot 2 if recording on card slot 1 is stopped.
- In the background recording mode, standard recording can be performed on card slot 1 if a memory card for recording is not inserted in card slot 2 or the remaining recording capacity of the memory card in card slot 2 has run out.
- When the capacity in the memory card in card slot 2 runs out during recording, background recording will not start automatically even if you replace the memory card in card slot 2.
- For information about recording functions that cannot be used simultaneously, refer to page 192.

\*1 The tally lamp can be used when the handle unit ( X2000 supplied, X1500 optional) is attached to the unit.

\*2 When using X2000, the <SDI OUT> terminal can be used.

## Ending background recording

- 1 Press and hold the USER button to which [BACKGR PAUSE] is assigned for approximately 5 seconds or touch and hold the USER button icon for approximately 5 seconds and release.

The background recording stops on card slot 1.

The background recording on card slot 2 can also be stopped by pressing and holding the <EXIT> button for approximately 5 seconds.

### NOTE

- The background recording on card slot 2 cannot end while recording is performed on card slot 1. End the background recording while recording is stopped on card slot 1.
- The background recording on card slot 2 ends in the following cases.
  - When the power is turned off
  - When the remaining recording capacity of the memory card has run out
  - When an error has occurred when writing to the memory card

## Interval recording

The unit will record 1 frame at each set time interval.

It is possible to record a short clip of a long slow-moving scene, such as a sunset, by recording with intervals between frames.

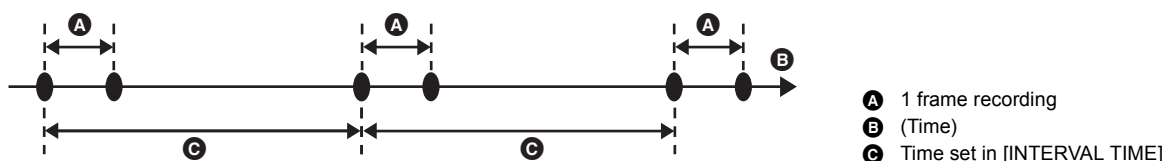

- 1 Select the [SYSTEM] menu → [FILE FORMAT] → [MOV].
- 2 Select the [RECORDING] menu → [REC FUNCTION] → [REC MODE] → [INTERVAL].  
[INTRVL] is displayed in the special recording function display of the camera image screen.
- 3 Set the time in the [RECORDING] menu → [REC FUNCTION] → [INTERVAL TIME].
- 4 Press the REC button.
  - [I-REC] is displayed in red in the special recording function display of the camera image screen.
  - The unit will repeat the operation of one frame recording at set time interval.
  - To stop recording, press the REC button.
  - Set [NORMAL] in the [RECORDING] menu → [REC FUNCTION] → [REC MODE] to clear the setting.

### NOTE

- In the following cases, [REC MODE] is fixed to [NORMAL].
  - When [SYSTEM] menu → [FILE FORMAT] is set to [MP4] or [AVCHD]
  - When [SYSTEM] menu → [SUPER SLOW] is set to [ON]
- The setting is cleared when the power is turned off.
- Audio is not recorded.
- Recorded data (data recorded until recording was stopped) is included in 1 clip.
- The [RECORDING] menu → [TC/UB] → [FREE/REC RUN] is fixed to [REC RUN].
- The [RECORDING] menu → [TC/UB] → [DF/NDF] is fixed to [NDF].
- (For the X1500)  
The [VIDEO OUT/LCD/VF] menu → [HDMI OUT] → [HDMI REC REMOTE] does not work.
- (For the X2000)  
The [VIDEO OUT/LCD/VF] menu → [SDI OUT] → [SDI REC REMOTE] and the [VIDEO OUT/LCD/VF] menu → [HDMI OUT] → [HDMI REC REMOTE] do not work.
- When [REC MODE] is set to [INTERVAL], the [DEL LAST CLIP] assigned to the USER button does not work.
- If the length of the clip is less than 3 seconds when the recording is stopped, the image of the final frame will be recorded to make the length of the clip to 3 seconds.
- Depending on the light source and the scene being recorded, color hue and focus may not be automatically set. In case such as this, try adjusting manually. (→ 111, 114)
- When recording for long periods, it is recommended to connect to the AC adaptor for recording.
- The recording is stopped once when the length of the clip exceeds 10 hours in the interval recording. The recording is automatically resumed after few seconds.
- For information about recording functions that cannot be used simultaneously, refer to page 192.

## IR recording

A night time shooting using the IR light can be performed.

### ■ Assigning [IR REC] to the USER button

#### 1 Select the [CAMERA] menu → [USER SW] → [USER1] to [USER12] → [IR REC].

Set so enable/disable of the IR recording can be switched with a USER button.

### ■ Performing IR recording

#### 1 Press the USER button to which [IR REC] is assigned or touch the USER button icon.

The unit will enter the IR recording mode.

- The following happens in the IR recording mode:
  - [IR] is displayed on the camera image screen.
  - Iris is automatically adjusted.

#### 2 Press the REC button.

IR recording is started.

### NOTE

- In the following case, this cannot be set.
  - When using the face detection/tracking AE&AF function
- This can also be set with the [CAMERA] menu → [SW MODE] → [IR REC].
- It is recommended to use a tripod.
- It takes longer to focus with Auto Focus in dark locations.
- You can record a clear image by positioning the center area of the screen over the subject.
- Focus values may not be displayed correctly in IR recording mode.
- It is also possible to change the color in which images are recorded in [IR REC COLOR] (→ 67)

## Convenient shooting functions

### Zebra patterns display

The unit can display 2 types of zebra patterns to the output image from the LCD monitor.

**1** Select the [VIDEO OUT/LCD/VF] menu → [EI ASSIST] → [ZEBRA] → [ON].

- You can also either press the USER button assigned to [ZEBRA] or touch the USER button icon to display the zebra pattern and switch display/hide. This changes depending on the [ZEBRA] settings.

[ZEBRA] settings	Operation when the USER button is pressed
[MOMENT]	Displays the zebra pattern for approximately 5 seconds.
[ON], [OFF]	Switches display/hide of the zebra pattern.

### Setting the detection level

**1** Set each item in the [VIDEO OUT/LCD/VF] menu → [EI ASSIST].

Item	Description of settings
[ZEBRA1 DETECT]	Sets the detection level of zebra pattern 1. [50%]...[105%]
[ZEBRA2 DETECT]	Sets the detection level of zebra pattern 2. [50%]...[105%]
[ZEBRA2]	Switches enable/disable of zebra pattern 2. [ON], [OFF]

### ■ Display area of the zebra pattern

The display area of the zebra pattern varies depending on the [VIDEO OUT/LCD/VF] menu → [EI ASSIST] setting.

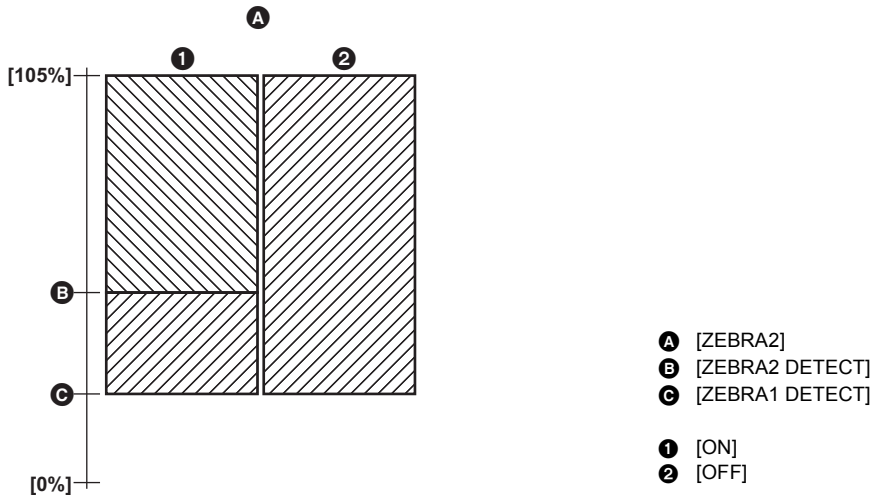

### NOTE

- The zebra pattern cannot be recorded.
- To record video with less overexposure, manually adjust the shutter speed and brightness (iris/gain) so that the zebra pattern is no longer displayed. (→ 108, 109, 112)

### Displaying the marker

#### Displaying the center marker

A center marker can be displayed.

**1** Select the type of the center marker in the [VIDEO OUT/LCD/VF] menu → [MARKER] → [CENTER MARKER].

[1]	[2]	[3]	[4]

- The center marker is not displayed when [OFF] is selected.

### Displaying the safety zone marker

A safety zone marker can be displayed.

- 1 Select the type of the frame in the [VIDEO OUT/LCD/VF] menu → [MARKER] → [SAFETY MARKER].

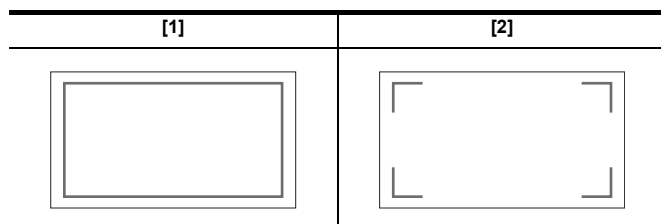

- The safety zone marker is not displayed when [OFF] is selected.

### Displaying frame marker

A frame marker can be displayed.

- 1 Select the angle of the view in the [VIDEO OUT/LCD/VF] menu → [MARKER] → [FRAME MARKER].

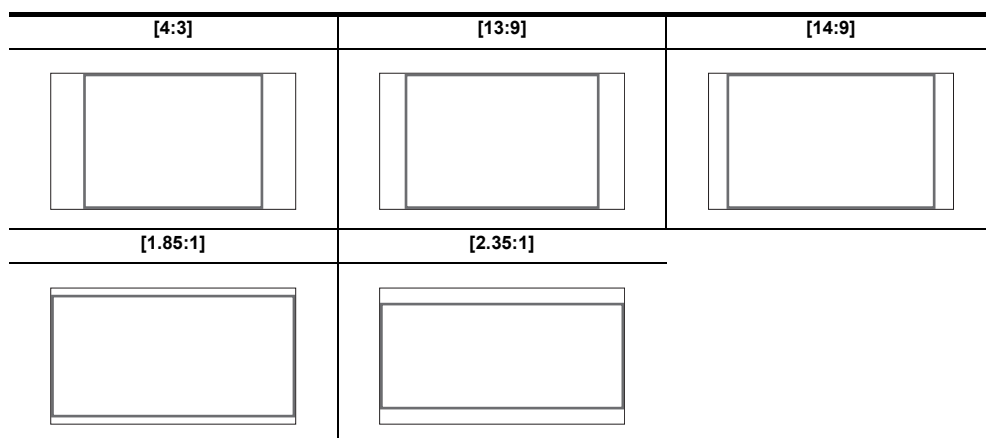

- The frame marker is not displayed when [OFF] is selected.

### NOTE

- Markers cannot be recorded.
- Markers are not displayed when the enlarged display function of the focus assist function is enabled.

### Focus assist function

The focus assist function enables you to focus the target easily.

The recording image on the LCD monitor and the viewfinder can be displayed enlarged, or the focused area can be visually enhanced.

### Enlarged display function

Center of the recording image is displayed enlarged to make it easier to focus.



### Using the enlarged display function

Set so enable/disable of the enlarged display function can be switched with a USER button.

- 1 Switch to manual mode with the <AUTO/MANU> switch. (→ 104)
- 2 Press the <FOCUS A/M/∞> button to switch to manual focus mode. (→ 111)
- 3 Select [VIDEO OUT/LCD/VF] menu → [FOCUS ASSIST] → [FOCUS ASSIST SW] → [EXPAND] or [EXPAND&PEAKING].
- 4 Select the [CAMERA] menu → [USER SW] → [USER1] to [USER12] → [FOCUS ASSIST].

**5 Press the USER button to which [FOCUS ASSIST] is assigned or touch the USER button icon.**

Press the USER button or touch the USER button icon again to return to the normal display.  
Pressing the <EXIT> button also returns to the normal display.

**Setting the mode for enlarged display function**

**1 Select the mode for the enlarged display function in the [VIDEO OUT/LCD/VF] menu → [FOCUS ASSIST] → [EXPAND MODE].**

- [10SEC]:** Disables the enlarged display function after 10 seconds have elapsed.
- [HOLD]:** Enables the enlarged display function until either the USER button assigned to [FOCUS ASSIST] is pressed again or the USER button icon is touched again.
- [UNTIL REC]:** Enables the enlarged display function until starting the recording operation.

**Setting the enlargement rate**

**1 Select the enlargement rate in the [VIDEO OUT/LCD/VF] menu → [FOCUS ASSIST] → [EXPAND VALUE].**

- The enlargement rate can be selected from [×2], [×3], or [×4].

**Setting the enlargement position**

You can select the central position of the enlarged display from the 9 base points.  
In the case of the multial: Turn the multial to move the enlarged position. It will return to center when the multial is pressed.  
In case of touching the LCD monitor: The enlarged position will move by touching the vertical and horizontal arrow markers on the LCD monitor.

- A** Base point
- B** Screen actually recorded
- C** Enlarged display part

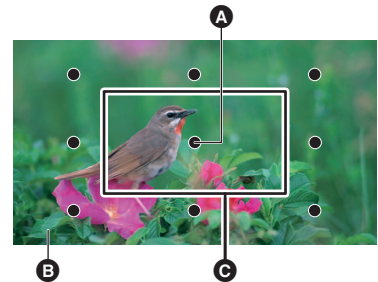

**Peaking display**

The peaking display will outline the contour of the focused image in red, green, or white.



- A** Peaking display

**Displaying the peaking display**

Set so enable/disable of peaking display can be switched with a USER button.

- 1 Switch to manual mode with the <AUTO/MANU> switch. (→ 104)**
- 2 Press the <FOCUS A/M/∞> button to switch to manual focus mode. (→ 111)**
- 3 Select [VIDEO OUT/LCD/VF] menu → [FOCUS ASSIST] → [FOCUS ASSIST SW] → [EXPAND] or [EXPAND&PEAKING].**
- 4 Select the [CAMERA] menu → [USER SW] → [USER1] to [USER12] → [FOCUS ASSIST].**
- 5 Press the USER button to which [FOCUS ASSIST] is assigned or touch the USER button icon.**

Press the USER button or touch the USER button icon again to return to the normal display.

**Setting the color for peaking display**

Sets the color of the peaking display.

**1 Select the color of the peaking display in the [VIDEO OUT/LCD/VF] menu → [FOCUS ASSIST] → [PEAKING COLOR].**

- The color of the peaking display can be selected from [RED], [GREEN], or [WHITE].



## Enlarged display and peaking display settings

**1** Select the type of display in the [VIDEO OUT/LCD/VF] menu → [FOCUS ASSIST] → [FOCUS ASSIST SW].

- [EXPAND]: Enables the enlarged display.  
 [PEAKING]: Enables the peaking display.  
 [EXPAND&PEAKING]: Enables the enlarged display and peaking display.

## Detail function (highlighting the outlines of images)

It is easier to focus if the contours of images on the LCD monitor and viewfinder are highlighted.

The intensity of contours on the LCD monitor does not affect the images output or recorded by the unit.

Set the intensity of contours in the [VIDEO OUT/LCD/VF] menu → [FOCUS ASSIST] → [DETAIL] → [ON] and adjust the [VIDEO OUT/LCD/VF] menu → [FOCUS ASSIST] → [DETAIL LEVEL]/[DETAIL FREQ.].

- You can also either press the USER button assigned to [LCD/VF DETAIL] or touch the USER button icon to switch enable/disable of the [DETAIL] menu.

### NOTE

- In the following cases, the focus assist function is canceled.
  - Power is turned off
  - Switch to auto mode with the <AUTO/MANU> switch
  - Press the <FOCUS A/M/∞> button to switch to auto focus mode.
  - Settings in the [VIDEO OUT/LCD/VF] menu → [FOCUS ASSIST] → [FOCUS ASSIST SW] are changed
- In the following cases, the enlarged display function is canceled.
  - When using the area mode function
  - When using the face detection/tracking AE&AF function
- In the following case, the detail function does not operate.
  - When the peaking display for focus assist is enabled
- The enlarged display cannot be recorded.
- The peaking display cannot be recorded.
- Some of the displays such as marker will be hidden temporarily during enlarged display.
- The enlarged display and peaking display are not shown on external monitors.

## Face detection/tracking AE&AF function

### Face detection AE&AF function

Faces are detected from images during recording, and the detected faces are focused on and the exposure is matched.

**1** Select the [CAMERA] menu → [USER SW] → [USER1] to [USER12] → [FACE DETECT].

**2** Switch to auto mode with the <AUTO/MANU> switch. (→ 104)

**3** Either press the USER button assigned to [FACE DETECT] or touch the USER button icon.

[FACE] is displayed on the camera image screen and face detection starts. (Face detection mode)

- Faces that are detected are displayed with an outline (orange for the dominant face **B**, white for detected faces **A**).  
Auto focus and exposure compensation are performed on the main face frame.
- The maximum number of face detection outlines is 9, with larger faces and the faces closer to the center of the screen prioritized.

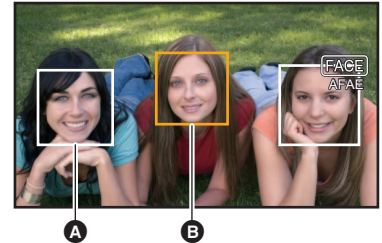

### Tracking AE&AF function

When you touch any of the subjects when in the face detection mode, focus and exposure continue automatically even if that subject moves. [TRACK] is displayed on the camera image screen and tracking starts. (Tracking mode)

- A green frame (tracking frame) is displayed on the subject that was touched.
- To change the subject being tracked, touch any subject.
- In the following cases, the unit returns to face detection mode.
  - Turn the power off and then on again.
  - The <THUMBNAIL> button is pressed to switch between the thumbnail screen and the camera image screen
  - Either press the USER button assigned to [FACE DETECT] or touch the USER button icon.
  - Press the <EXIT> button.
  - When it is no longer possible to track the touched subject\*



\* The tracking frame flashes red, then goes out after approximately 3 seconds. The tracking mode continues if the subject is detected before the tracking frame goes out or if a different subject is touched.

### NOTE

- In the following cases, it cannot be used.
  - When set to manual mode
  - When set to digital zoom
  - When using the area mode function
  - When IR recording is enabled
  - When super slow recording is enabled
- In the [CAMERA] menu → [SW MODE] → [FACE DETECT/TRACKING MODE], you can switch whether to perform only auto focus or to perform both auto focus and exposure compensation. (→ 67)
- The face detection frame and tracking frame are not output to an external device in the following case:
  - When the [VIDEO OUT/LCD/VF] menu → [HDMI OUT] → [OUT FORMAT] is set to [720×480p]/[720×576p] and the TV/external monitor is connected with an HDMI cable

(Tracking AE&AF function)

- The subject cannot be touched in the mirror shooting mode.

## Optical image stabilizer function

Camera shake can be reduced by using the optical image stabilizer function when shooting while holding the main unit by hand.

You can use the hybrid optical image stabilizer function.

The hybrid optical image stabilizer function is an optical image stabilizer that combines optical and electronic methods.

### Switching enable/disable of the optical image stabilizer function

**1** Select the [CAMERA] menu → [SW MODE] → [O.I.S.] → [ON].

- You can also either press the USER button\* assigned to [O.I.S.] or touch the USER button icon to enable/disable the optical image stabilizer function.
- \* [O.I.S.] is set in the <O.I.S.>/<USER3> button at the time of purchase.
- Refer to page 50 for USER button settings.

### Switching enable/disable of the hybrid optical image stabilizer function

**1** Select the [CAMERA] menu → [SW MODE] → [O.I.S.] → [ON].

**2** Select the [CAMERA] menu → [SW MODE] → [HYBRID O.I.S.] → [ON].

Enable the hybrid optical image stabilizer function for more powerful image stabilization when holding the main unit and shooting a subject far away with zoom.

When the hybrid optical image stabilizer function is enabled,  is displayed on the LCD monitor.

#### NOTE

- In the following cases, [HYBRID O.I.S.] is fixed to [OFF]:
  - When [O.I.S.] is [OFF]
  - When recording with super slow
- Stabilization may not be possible where camera shake is large.
- When recording with a tripod, it is recommended to turn [O.I.S.] [OFF].

### Optical image stabilizer settings according to shooting conditions

You can set the optical image stabilizer settings according to the shooting conditions.

**1** Select the [CAMERA] menu → [SW MODE] → [O.I.S.] → [ON].

**2** Select the [CAMERA] menu → [SW MODE] → [O.I.S. MODE] → [NORMAL]/[PAN/TILT]/[STABLE].

[NORMAL]: Specifies the standard setting for a good balance of correction for large and small camera shake.

[PAN/TILT]: Specifies a setting appropriate for shooting that uses a lot of panning and tilting of the camera.

[STABLE]: Specifies a setting appropriate for fixing a composition to shoot a subject.

#### NOTE

- Stabilization may not be possible when the unit has a large amount of shake.
- When using a tripod, disabling the optical image stabilizer function will allow you to obtain natural images.

### Dynamic range stretcher function

By compressing the video signal levels of the high luminosity areas that are blown out in normal shooting while maintaining the contrast, the dynamic range can be expanded.

### Switching enable/disable of the dynamic range stretcher function

**1** Select the [SCENE FILE] menu → [DRS] → [ON].

- You can also either press the USER button assigned to [DRS] or touch the USER button icon to switch enable/disable of the dynamic range stretcher function.

### Setting the dynamic range stretcher effect

**1** Select the compression level with the [SCENE FILE] menu → [DRS EFFECT DEPTH].

#### NOTE

- In the following case, [DRS] cannot be set:
  - During Super Slow Recording
- If there are extremely dark or bright parts or the brightness is insufficient, the effect may not be clear.

## Time stamp function

You can record the date and time of shooting on the images.

### 1 Select the information to record in the [RECORDING] menu → [TIME STAMP].

[OFF]: Does not superimpose the date and time.

[DATE]: Superimposes only the date.

[TIME]: Superimposes only the time.

[DATE&TIME]: Superimposes the date and time.

The date and time of recording is displayed in the bottom-center of the LCD monitor.

#### NOTE

- The order to display the year, month, and day of the time stamp follows the settings in the [OTHERS] menu → [CLOCK] → [DATE FORMAT].
  - The display of the month for the time stamp to record on the image is in English.
  - The size of the characters and the display position of the time stamp varies depending on the recording format.
  - The time stamp is not recorded in the following cases.
    - When the [SYSTEM] menu → [SUPER SLOW] → [ON] is set
    - When the [NETWORK] menu → [NETWORK FUNC] → [STREAMING] is set
  - The position to display the time stamp can not be changed.
  - The time stamp is displayed even in the screen of the LCD monitor, the image of the viewfinder, and the image output from the <SDI OUT>\*/<HDMI> terminals.
 

For the following recording formats, the time stamp displayed on the LCD monitor/viewfinder images will have a different character size and display position to the time stamp recorded.

    - Recording formats with 1280×720 resolution
  - The external output is delayed by one frame when superimposing the time stamp.
  - The [VIDEO OUT/LCD/VF] menu → [INDICATOR] → [DATE/TIME] setting is disabled when superimposing the time stamp.
  - The time stamp is an image signal recorded superimposed to the subject. Therefore, the peaking display of the focus assist function and zebra pattern detection are enabled also to the time stamp display. The time stamp is also displayed horizontally inverted when set to the [VIDEO OUT/LCD/VF] menu → [LCD] → [SELF SHOOT] → [MIRROR].
- \* When using **X2000**, the <SDI OUT> terminal can be used.

## Waveform monitor function

Waveform of the image can be displayed.

### ■ Assigning [WFM] to the USER button

Set so display/hide of the waveform monitor can be switched with a USER button.

### 1 Select the [CAMERA] menu → [USER SW] → [USER1] to [USER12] → [WFM].

### ■ Displaying the waveform monitor

### 1 Press the USER button assigned to [WFM] or touch the USER button icon.

Press the USER button or touch the USER button icon again to return to the normal display.

- The display switches each time the USER button is pressed or the USER button icon is touched when the [VIDEO OUT/LCD/VF] menu → [EI ASSIST] → [WFM MODE] → [WAVE/VECTOR] is set.

## Setting the displaying of the waveform monitor

Displaying of the waveform and the vector can be switched.

### 1 Select the display of the waveform monitor in the [VIDEO OUT/LCD/VF] menu → [EI ASSIST] → [WFM MODE].

[WAVE]: Displays the waveform.

[VECTOR]: Displays the vector.

[WAVE/VECTOR]: Displays the waveform and the vector. Each time you either press the USER button assigned to [WFM] or touch the USER button icon, the display switches in the order waveform, vector, no display.

## Setting the transmittance

The transmittance of the waveform monitor can be set.

### 1 Select the transmittance in the [VIDEO OUT/LCD/VF] menu → [EI ASSIST] → [WFM TRANSPARENCE].

- The transmittance can be selected from [0%], [25%], or [50%].

#### NOTE

- The waveform monitor cannot be recorded.
- The waveform monitor is not displayed when using enlarged display function in the focus assist function.
- The waveform monitor is automatically displayed when setting some of the menu to perform the image quality adjustment.

## Digital zoom function

### ■ Assigning [D.ZOOM] to the USER button

Set so enable/disable of the digital zoom function can be switched with a USER button.

**1** Select the [CAMERA] menu → [USER SW] → [USER1] to [USER12] → [D.ZOOM].

### ■ Using the digital zoom function

**1** Press the USER button to which [D.ZOOM] is assigned or touch the USER button icon.

Each time you either press the USER button or touch the USER button icon, the enlargement rate switches in the order 2×, 5×, 10×, disabled.

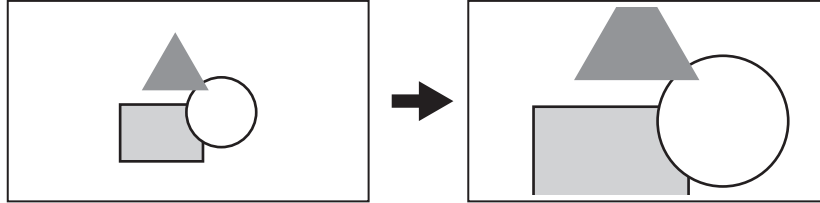

### NOTE

- The image quality decreases the higher the enlargement ratio when using the digital zoom.
- In the following cases, digital zoom cannot be used:
  - When using the area mode function
  - During Super Slow Recording
  - When using the face detection/tracking AE&AF function
- The digital zoom is cancelled when the power is turned off.

## Level gauge

A level gauge that indicates the horizontal and vertical inclinations of the unit can be displayed on the LCD monitor.

The line of the level gauge is displayed in orange while the unit is inclined. The line of the level gauge will change from orange to light blue, and then to white when the inclination of the unit is corrected. It will indicate up to approximately 30° in horizontal direction, and 30° in vertical direction.

**1** Select the [VIDEO OUT/LCD/VF] menu → [LEVEL GAUGE] → [LEVEL GAUGE] → [ON].

### NOTE

- The display of level gauge cannot be recorded.
- The level gauge is not displayed when the enlarged display function of the focus assist function is enabled.
- If [SELF SHOOT] (→ 77) is set to [MIRROR], the electronic level will not be displayed when you record yourself.
- Even when the level gauge line is white, there still may be an incline of approximately 1°.
- The level gauge may not display correctly while moving the unit.
- The level gauge may not display correctly when shooting with the unit inclined excessively upward or downward.
- You can either press the USER button assigned to [LEVEL GAUGE] or touch the USER button icon to switch display/hide of the level gauge. [LEVEL GAUGE] is set in the <USER1> button at the time of purchase.
- You can either press the USER button assigned to [LEVEL GAUGE SET] or touch the USER button icon to set the current horizontal and vertical directions as the reference value of the level gauge. Restore the set value in the [VIDEO OUT/LCD/VF] menu → [LEVEL GAUGE] → [LEVEL GAUGE RESET].
- Refer to page 50 for USER button settings.

## Operation icon screen display

You can select the scene file or execute the functions assigned to [USER6] through [USER12].

### Displaying the operation icon screen

**1** Either touch and hold the screen for approximately 2 seconds in the camera recording screen, or press the multialdial when [ICONS] is displayed.

- The operation icon screen is displayed.
- The unit returns to the camera image screen from the operation icon screen in the following cases.
- When the <EXIT> button is pressed
  - When anything other than the icon is touched
  - When the touch operation of the LCD monitor is not performed for approximately 5 seconds

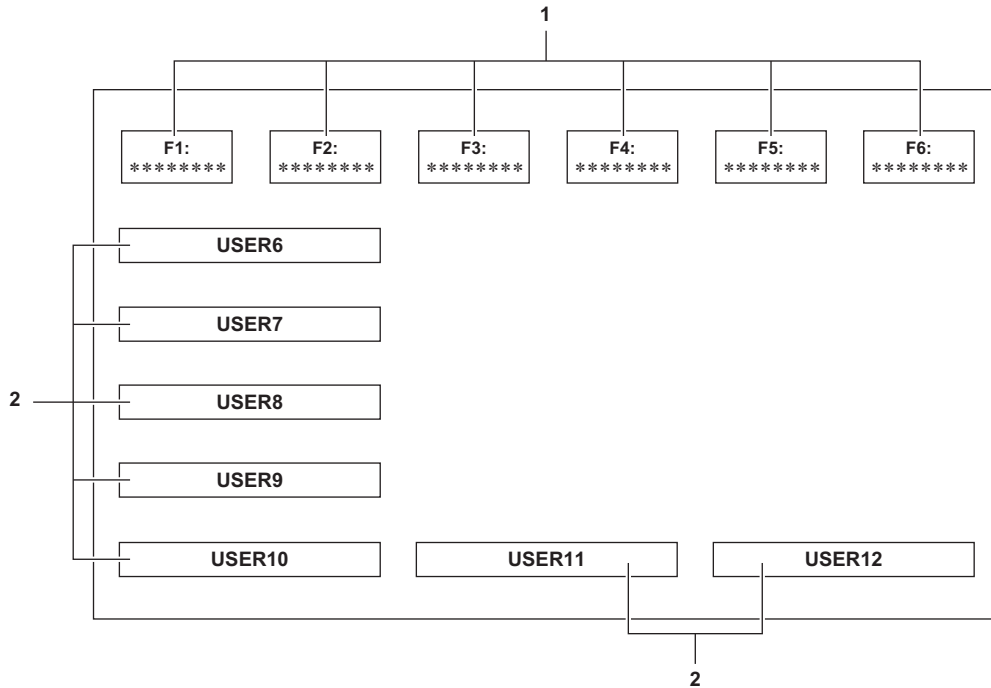

**1 Scene file (1 to 6) icon**

Either press the multialdial with the cursor in position or touch the icon to select each of the scene files. The name of each scene file is displayed on the second line of the icon.

**2 [USER6] to [USER12] icon**

Either press the multialdial with the cursor in position or touch the icon to execute the functions assigned to each of [USER6] to [USER12]. Each function assigned to [USER6] through [USER12] is displayed in the icon.

## Multi manual function

Operate the multidial to change settings and perform other operations without displaying the menu. You can also switch between the functions and adjust their settings.

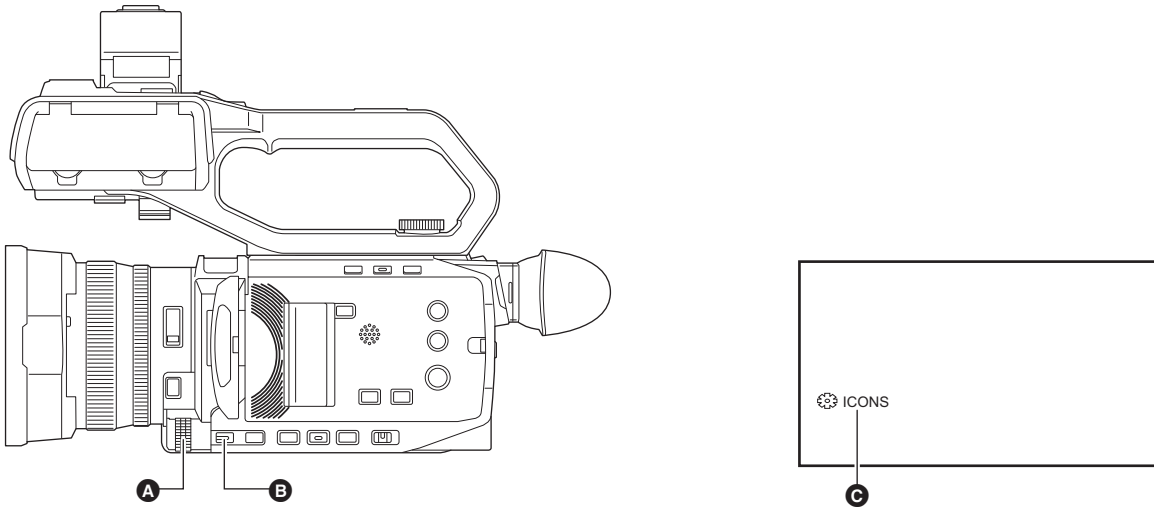

- A** Multidial  
**B** <EXIT> button

- C** Multi manual function

You can execute the following functions.

Display of the camera image screen	Function
[ ICONS]	Displays the operation icon screen.
[ GAIN]	Sets the gain value. (→ 109)
[ SHUTTER]	Sets the shutter speed. (→ 112)
[ WB]	Sets the variable value for the white balance. (→ 116)
[ IRIS]	Sets the iris value. (→ 108)
[ AE LEVEL]	Sets the exposure compensation value (→ 110)
[ AREA]	Adjusts the area size of the area mode function.
[ AUDIO MON]	Adjusts the headphone volume.

### To change the function you adjust

#### 1 Make the settings to enable selection of the multi manual function.

Set items other than [ ICONS] and [ AUDIO MON] as follows.

[ GAIN]	Set to manual gain mode (→ 109)
[ SHUTTER]	Set to manual shutter mode (→ 112)
[ WB]	Press the <WHITE BAL> button and the USER button assigned to [AWB] to switch white balance to "VAR" (→ 116)
[ IRIS]	Set to manual iris mode (→ 108)
[ AE LEVEL]	Set [AE LEVEL] to [ON] and set one of iris, gain, or shutter to auto (→ 110)
[ AREA]	Press the USER button assigned to [AREA] to turn the area function on (→ 112)

- If [ ICONS] is selected, turn the multidial to select the operation icon.

#### 2 Turn the multidial to select the function you want to set, then press the multidial to confirm.

The screen display for the selected function is highlighted in orange.

#### 3 Press the multidial to end the settings.

## Displaying the operation icon screen

- 1 Turn the multidial to display the [  ICONS].**
- 2 Press the multidial.**

The operation icon screen is displayed.

## Adjusting headphone volume

Adjust the headphone volume during recording.

- 1 Connect the headphones to the headphone terminal.**
- 2 Turn the multidial to display [  AUDIO MON].**
- 3 Press the multidial.**
- 4 Turn the multidial to adjust the volume.**

There is no change to the sound that is actually recorded.
- 5 Press the multidial.**

The setting changes to the value displayed and exits.  
Press the <EXIT> button to exit without changing the setting.

---

### **NOTE**

- If no operations are performed in Step 4, the setting is ended.



## Chapter 6

# Playback

---

Data including additional information such as image, audio, and meta data that are recorded by single shooting is saved as a clip. Playback, copy, etc., of the clip can be performed on the unit.

## Thumbnail operation

### Thumbnail operation overview

A clip is a group of data recorded by a single shooting, which includes additional information such as image, audio, and meta data. The following operations can be performed while viewing the clip thumbnails displayed on the LCD monitor.

- Playback
- Delete
- Protect (only the clips recorded in MOV/MP4/AVCHD)
- Copy (only the clips recorded in AVCHD)

You can do these operations either with the multi-dial or by touching the LCD monitor.

#### NOTE

- You can switch the memory card to be played back by pressing the <SLOT SEL> button.

### Thumbnail screen

Press the <THUMBNAIL> button to display the thumbnail screen while displaying the camera image screen.

Press the <THUMBNAIL> button again to display the camera image screen.

The clips in the recording file format (MOV/MP4/AVCHD) selected in the [SYSTEM] menu → [FILE FORMAT] are displayed in the thumbnail screen.

- When you press the <MENU> button while displaying the thumbnail screen, you can perform thumbnail screen menu operations.

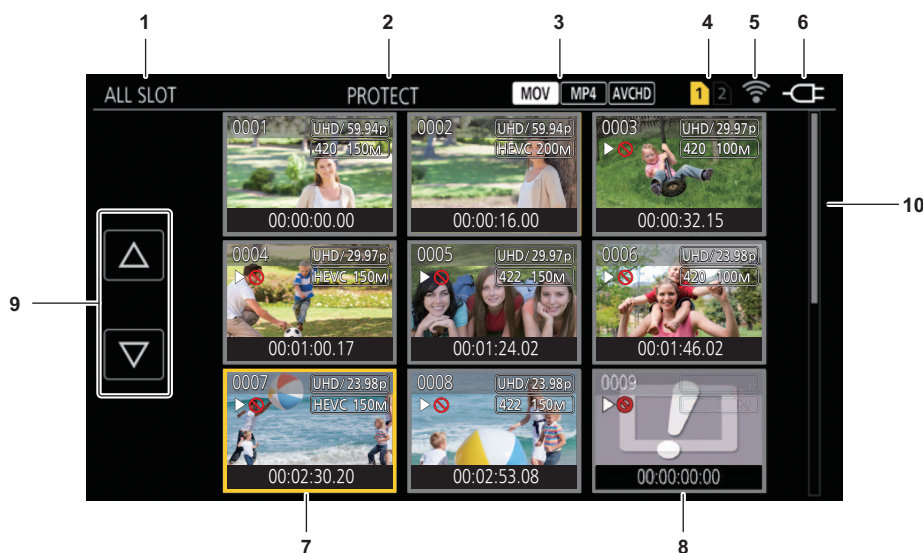

#### 1 Clip status display

**[ALL SLOT]:** Displays all the clips recorded on every memory card in each card slot. Displays in [ALL SLOT] when the thumbnail screen is displayed from the camera image screen.

**[SLOT1]:** Displays only the clips recorded on the memory card in card slot 1.

**[SLOT2]:** Displays only the clips recorded on the memory card in card slot 2.

**[SLOT1→SLOT2]:** Displayed when copying from the memory card in card slot 1 to the memory card in card slot 2.

**[SLOT2→SLOT1]:** Displayed when copying from the memory card in card slot 2 to the memory card in card slot 1.

**[SAME FORMAT]:** Displays only the clips recorded in the same format as the system format.

- Clips recorded in the same format match the current settings for each item of the [SYSTEM] menu → [FREQUENCY]/[FILE FORMAT]/[REC FORMAT].

#### 2 Function display

This is displayed during the operation of copy, delete, protect, etc.

#### 3 File format

**MOV** : Displayed when MOV is selected as the recording file format.

**MP4** : Displayed when MP4 is selected as the recording file format.

**AVCHD** : Displayed when AVCHD is selected as the recording file format.

**MOV** : Displayed when MP4, or AVCHD is selected as the recording file format and when even one MOV clip is on any of the memory cards.

**MP4** : Displayed when MOV, or AVCHD is selected as the recording file format and when even one MP4 clip is on any of the memory cards.

**AVCHD** : Displayed when MOV, or MP4 is selected as the recording file format and when even one AVCHD clip is on any of the memory cards.

#### 4 Media status display

The card slot number of the memory card where the clip in the cursor position is recorded is displayed in yellow.

#### 5 Displaying the connection status of the wireless LAN

Displays the connection status of the wireless LAN.

(No display): It is not connected to the wireless LAN. It is set to the [NETWORK] menu → [DEVICE SEL] → [OFF].

 : A status where the wireless LAN is set and ROP is not connected.

 : A status where the wireless LAN is set and ROP is connected.

**6 Power status display**

- : Displays the remaining battery level while powered with the battery.
- : Displayed when powered with the AC adaptor.

**7 Cursor**

**8 Clip that cannot be played back**

Displays when the clip cannot be played back in the unit such as standard violation.

**9 Page switching button**

Switches the page of the thumbnail screen.

- : Moves to previous page
- : Moves to next page

**10 Scroll bar**

Indicates which part of the whole thumbnail is currently being viewed.

**Display of the clips in the thumbnail screen**

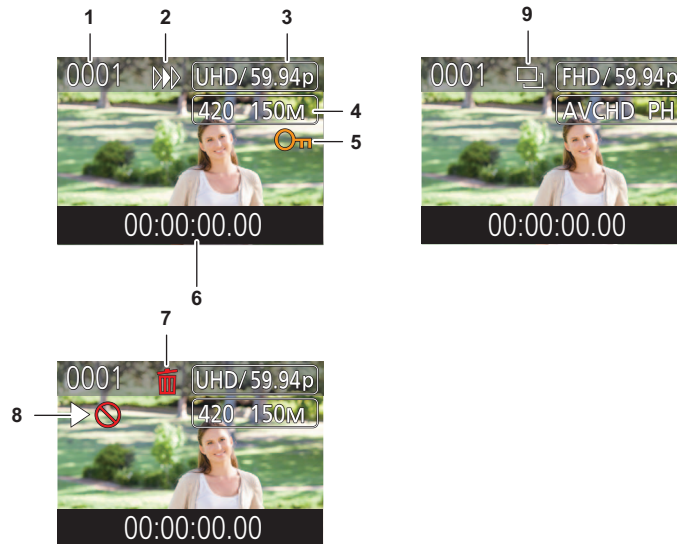

**1 Thumbnail number**

Displays the thumbnail number in [0001] to [9999].  
Normally, the number assigned to the clip in the order of recording is displayed.

**2 Resume play status**

**3 Number of recording pixels, system frequency**

**4 Recording file format, recording codec**

**5 Protection status of the clip**

This is displayed when the clip is protected.

**6 Standard time code/clip name**

The first 8 digits for the time code when starting shooting of a clip or the file name of the clip are displayed in alphanumeric.  
The information to display is set in the [THUMBNAIL] menu → [DISPLAY] → [DATA].

**7 Delete selection status**

**8 Clip that cannot be played back**

This is displayed when the clip cannot be played back with the unit because the system frequency is different, etc.

**9 Copy selection status**

This is displayed when the clip is selected.

## Display of clip information

Displays the information of the clip where the cursor is positioned.

**1** Move the yellow cursor to the clip to display the clip information.

**2** Select the [THUMBNAIL] menu → [CLIP] → [INFORMATION].

The clip information is displayed.

### ■ Clip information

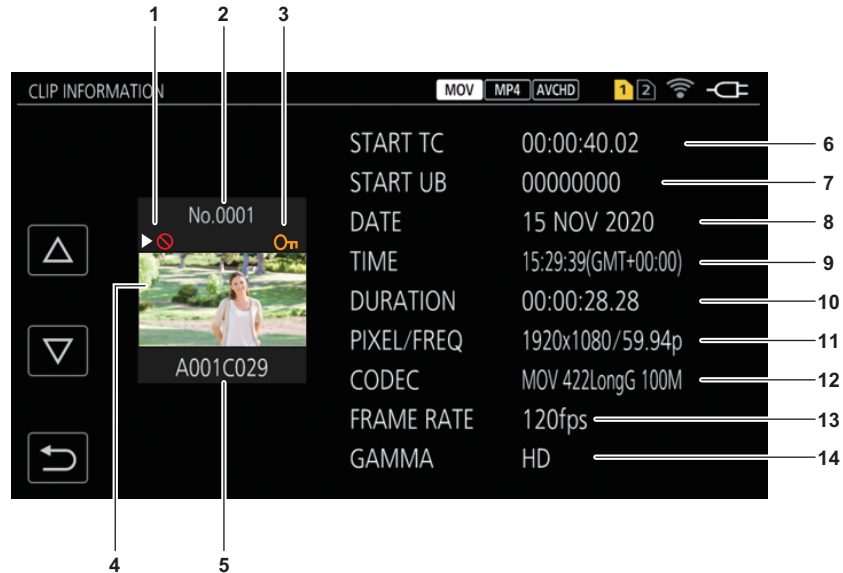

**1** **Clip that cannot be played back**

This is displayed when the clip cannot be played back with the unit because the system frequency is different, etc.

**2** **Thumbnail number**

**3** **Protect status of the clip**

**On**: This is displayed when the clip is protected.

**4** **Thumbnail image**

**5** **Clip name**

**6** **[START TC]**

Displays the time code value at the start of the recording.

**7** **[START UB]**

Displays the user bits value at the start of the recording.

**8** **[DATE]**

Displays the date of the recording.

**9** **[TIME]**

Displays the time at the start of recording.

**10** **[DURATION]**

Displays the time length of the clip.

**11** **[PIXEL/FREQ]**

Displays the recording format of the clip.

**12** **[CODEC]**

Displays the recording file format and the recording codec of the clip.

**13** **[FRAME RATE]**

Displays the frame rate for super slow recording.

**14** **[GAMMA]**

Displays the gamma of the clip.

Displayed when the [SYSTEM] menu → [FILE FORMAT] is set to other than [AVCHD].

## Copying clip

Clips can be copied between memory cards.  
Only the clip recorded in AVCHD can be copied.

### 1 Press the <THUMBNAIL> button.

The thumbnail screen is displayed.

### 2 Press the <MENU> button while the thumbnail screen is displayed.

The menu is displayed.

### 3 Select the [THUMBNAIL] menu → [CLIP] → [COPY] → [SELECT].

- Selecting [ALL] copies all the clips between the memory cards.

### 4 Select the card slot for the copy destination.

[SLOT1→SLOT2]: Copies clips from the memory card in card slot 1 to the memory card in card slot 2.

[SLOT2→SLOT1]: Copies clips from the memory card in card slot 2 to the memory card in card slot 1.

The clips on the memory card of the copy source is displayed in the thumbnail screen.

### 5 Select the clip to copy in the thumbnail screen.

 is displayed on the selected clip.

### 6 Select [].

- This can also be selected by pressing and holding the multi dial.



### 7 When the confirmation message is displayed, select [SET].

Progress bar is displayed, and the copy of the clip starts.

- To cancel the copy midway, select [CANCEL].

### 8 When the completion message is displayed, select [].

#### NOTE

**When deleting clips after copying is complete, before deletion make sure you play back the copied clip to confirm that it has been copied properly.**

- When there are a large number of clips, it may take longer to copy the clips.
- The clip whose recording file format is MOV/MP4 cannot be copied.
- The copy is not possible when the volume of the selected clip is larger than the available card capacity of the destination.
- It cannot copy when the copy destination card is write protected.
- The copy is not possible when the maximum number of the clips will exceed.
- The copy is not possible when the maximum number of the playlist will exceed.
- It may not be possible to copy clips recorded on other equipment. Data that was recorded on a computer cannot be copied.
- The protection setting for clips is cleared when they are copied.
- The order of clips copied cannot be changed.

## Deleting clips

Deletes the clip.

**1 Press the <THUMBNAIL> button.**

The thumbnail screen is displayed.

**2 Press the <MENU> button while the thumbnail screen is displayed.**

The menu is displayed.

**3 Select the [THUMBNAIL] menu → [CLIP] → [DELETE] → [SELECT].**

The thumbnail screen is displayed.

- When [ALL] is selected, all the clips displayed in the thumbnail screen are deleted.  
The clip that is not displayed in the thumbnail screen is not deleted.

**4 Select the clip to delete in the thumbnail screen.**

 is displayed on the selected clip.

**5 Select [DEL].**

- This can also be selected by pressing and holding the multimedia.



**6 When the confirmation message is displayed, select [SET].**

Progress bar is displayed, and the deleting of the clip starts.

- To cancel midway, select [CANCEL].
- To continue to delete other clips, repeat Steps 4 to 6.

**7 When the completion message is displayed, select [↶].**

 **NOTE**

- The protected clip cannot be deleted.
- You cannot delete clips when the card with the clip to delete is write protected.
- You cannot delete clips (thumbnail display is ) that cannot be played back.
- It may take some time if all clips were selected for deletion in Step 3.

## Protecting clips

The clip recorded in MOV, MP4 or AVCHD can be protected.

**1 Press the <THUMBNAIL> button.**

The thumbnail screen is displayed.

**2 Press the <MENU> button while the thumbnail screen is displayed.**

The menu is displayed.

**3 Select the [THUMBNAIL] menu → [CLIP] → [PROTECT] → [SELECT].**

The thumbnail screen is displayed.

**4 Select the clip to protect in the thumbnail screen.**

 is displayed on the selected clip.

- Protect is canceled when the protected clip is selected.

 **NOTE**

- You cannot protect clips when the card with the clip to protect is write protected.

## Restoring clips

In following cases, restoration of the clip may be required depending on the condition. It may take some time to restore depending on the error.

- When the memory card in the card slot that is flashing is removed while the card 1 access lamp or the card 2 access lamp is flashing
- When the power is turned off by removing the battery or the AC adaptor while recording or performing record completion process

### Restoring a clip (MOV format/MP4 format/AVCHD format)

When either MOV, MP4, or AVCHD is selected as the recording file format, the error message [There are clips that need restoration.] is displayed on the screen when abnormal management information is detected.

#### 1 Select [SET] in the error message screen.

- Once the repair is completed, select [↩] in the confirmation message. It will return to the previous screen.
-  is displayed on the clip when an abnormal management information is detected while displaying the thumbnail.

#### NOTE

- Do not remove the memory card in the card slot that is flashing, or do not remove the battery or the AC adaptor when the card 1 access lamp/card 2 access lamp is flashing in orange. Doing so will cause damage to the memory card.
- Use a sufficiently charged battery or AC adaptor.
- It may not be possible to completely repair depending on the condition of the data.
- To restore the clips, it is necessary that the clips are recorded for more than a certain amount of time. Especially in the following cases, the clips may not be restored, because the number of frames to be recorded is small.
  - When the interval recording function is enabled.
- The clips shot before the power was turned off will not be able to play back if the repair fails. Also, it may not be possible to record any more.
- If data recorded with other device is repaired, it may not be able to play back on the unit or other device.
- If the repair failed, turn off the unit, and turn it back on after waiting for a while. If the repair fails repeatedly, format with the unit. All data will be erased when it is formatted, and it cannot be restored.
- Display of the thumbnail become slower when the thumbnail information is repaired.

Playing back clips



- 1 In the [SYSTEM] menu → [FREQUENCY], select the system frequency to play back.
- 2 In the [SYSTEM] menu → [FILE FORMAT], select the file format to play back.
- 3 In the [SYSTEM] menu → [REC FORMAT], select the signal format and codec mode to play back.
- 4 Press the <THUMBNAIL> button.  
The thumbnail screen is displayed.
- 5 Press the <MENU> button while the thumbnail screen is displayed.  
The menu is displayed.
- 6 In the [THUMBNAIL] menu → [PLAYBACK] → [CLIP SEL], select the card slot of the memory card to play back.  
 [ALL SLOT]: Displays all the clips recorded on every memory card in each card slot.
  - Displays in the order of the clips in card slot 1, and then clips in the card slot 2 when MOV, MP4 or AVCHD is selected as the recording file format.
 [SLOT1]: Displays only the clips recorded on the memory card in card slot 1.  
 [SLOT2]: Displays only the clips recorded on the memory card in card slot 2.  
 [SAME FORMAT]: Displays only the clips recorded in the same format as the system format.
  - Clips recorded in the same format match the current settings for each item of the [SYSTEM] menu → [FREQUENCY]/[FILE FORMAT]/[REC FORMAT].
- 7 Select the clip to play back.
  - ▷⊘ is displayed on the clip that cannot be played back.
  - To play back the clip with ▷⊘ displayed, check the information of the clip with the clip information, and try operating from the beginning again.

Playback from touch operations and operation icons

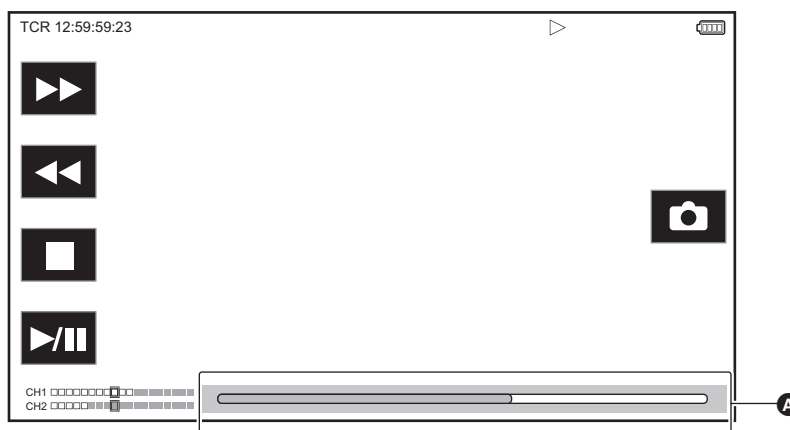

A Direct playback bar

Playback operation	Operating procedure
Playback/pause	Touch ►  .
Fast-reverse playback	Touch ◀◀. Touch twice to increase the speed.
Fast-forward playback	Touch ▶▶. Touch twice to increase the speed.
Stop (return to thumbnail screen)	Touch ■.



Playback operation	Operating procedure
Skip playback (cue up of the clip)	Touch the LCD monitor while playing back, and slide from right to left (left to right). When sliding from left to right, the clip skips to the beginning of the previous clip if the current playback position of the clip is at less than 3 seconds from the beginning. The clip skips to the beginning of the current clip if the current playback position of the clip is at 3 seconds or more from the beginning.
Slow playback	Touch and hold <b>⏮</b> while paused. ( <b>⏮</b> is reverse slow playback) When <b>⏮</b> is touched, slow playback is performed with continuous frame-by-frame playback. When <b>⏭</b> is touched, playback returns to normal. The frame-by-frame interval and the display time for each frame for the reverse slow playback differ depending on the type of the clip.
Frame-by-frame playback	Touch <b>⏮</b> while paused. ( <b>⏮</b> is reverse frame-by-frame playback) When <b>⏭</b> is touched, playback returns to normal. The frame-by-frame interval for reverse frame-by-frame playback differs depending on the type of the clip.
Direct playback	Touch the direct playback bar, or slide it while touching. The playback video is paused during the operation. Playback is started by releasing the finger.

**NOTE**

- If the operation icons are displayed but not touched for a while, the operation icons disappear. To display again, touch the screen.
- Operations of the unit or some performance may become slow for the clip with large file size.
- Operations of the unit or some performance may become slow when there are large number of clips on the memory card.
- Playback will stop once by switching the card slot when MOV, MP4 or AVCHD is selected as the recording file format, and the [THUMBNAIL] menu → [PLAYBACK] → [CLIP SEL] → [ALL SLOT]/[SAME FORMAT] is set, and then the clips of all the memory cards are displayed. Playback is not possible across 2 memory cards.
- Playback stops when the memory card is removed during playback.

**Motion picture compatibility**

- This unit is based on AVCHD Progressive/AVCHD.
- Even if the devices used have compatible standards, when playback of clip recorded using another device is performed using this device, or when clip recorded using this device is played back in another device, playback may not proceed normally, or may not be possible. (Please check compatibility in the instruction manual of your device.)
- Clips recorded with devices other than this unit are not supported by this unit.

**Adjusting the volume during playback**

You can adjust the playback volume by operating the zoom lever (on the grip).

**Towards <T>:** Raise the volume

**Towards <W>:** Lower the volume

- If no operations are performed, the setting is ended.
- The <EXIT> button is disabled.

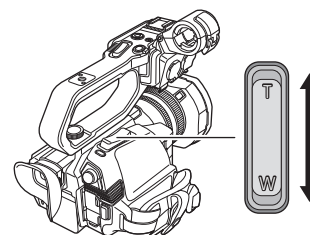

**NOTE**

- The zoom lever (on the handle) cannot be used to adjust the volume.

## Useful playback function

---

### Resume play

When the playback of a clip is stopped midway, it will start the playback from the position that stopped the playback when it is played back the next time.

**1** Select the [THUMBNAIL] menu → [PLAYBACK] → [RESUME PLAY] → [ON].

When the playback of a clip is stopped midway, [▶▶] is displayed on the clip in the thumbnail screen.

#### NOTE

- Resume playback is canceled in following cases. (The [RESUME PLAY] setting cannot be set to [OFF].)
  - When the power is turned off
  - When the thumbnail screen is canceled by pressing the <THUMBNAIL> button
  - When the [SYSTEM] menu → [REC FORMAT] is change

## Still image recording function

One frame of the recorded video can be recorded as a still image.

Number of pixels of the still image to be recorded is same as the number of pixels of the recorded video.

### 1 Select by touching or pressing the multi-dial at the scene to be recorded as a still image while playing back.

The still image is recorded in the memory card being played back.

- It is convenient to use Pause, Slow-motion Playback and Frame-by-frame Playback.



#### NOTE

- The playback will pause when a still image is recorded.
- Recorded still image cannot be displayed in thumbnail, played back, copied, or deleted in the unit.
- [INVALID] is displayed when the still image cannot be recorded in cases such as there is not enough remaining recording capacity in the memory card.

## Chapter 7 **Output and Screen Display**

---

This chapter describes the screen displayed on the output video and LCD monitor.

## Output format

The format to be output differs depending on the setting in the [SYSTEM] menu → [FREQUENCY]/[REC FORMAT].

### Format that can be output from the <SDI OUT> terminal [X2000]

The format that can be output from the <SDI OUT> terminal differs with following combination of the settings.

- [SYSTEM] menu → [FREQUENCY]
- [SYSTEM] menu → [REC FORMAT]
- [VIDEO OUT/LCD/VF] menu → [SDI OUT] → [OUT FORMAT]

[FREQUENCY]	Item		[OUT FORMAT]: Output Format		
	[REC FORMAT]				
	Resolution	Frame rate			
[59.94Hz]	3840×2160	59.94p	[1920×1080p]: [1920×1080i]*:	1920×1080/59.94p 4:2:2 10 bit 1920×1080/59.94i 4:2:2 10 bit	
		29.97p	[1920×1080p]: [1920×1080PsF]*:	1920×1080/29.97p 4:2:2 10 bit 1920×1080/29.97PsF 4:2:2 10 bit	
		23.98p	[1920×1080p]: [1920×1080PsF]*:	1920×1080/23.98p 4:2:2 10 bit 1920×1080/23.98PsF 4:2:2 10 bit	
	1920×1080	59.94p	[1920×1080p]: [1920×1080i]*:	1920×1080/59.94p 4:2:2 10 bit 1920×1080/59.94i 4:2:2 10 bit	
		59.94i	[1920×1080i]:	1920×1080/59.94i 4:2:2 10 bit	
		29.97p	[1920×1080p]: [1920×1080PsF]*:	1920×1080/29.97p 4:2:2 10 bit 1920×1080/29.97PsF 4:2:2 10 bit	
		23.98p	[1920×1080p]: [1920×1080PsF]*:	1920×1080/23.98p 4:2:2 10 bit 1920×1080/23.98PsF 4:2:2 10 bit	
	1280×720	59.94p	[1280×720p]:	1280×720/59.94p 4:2:2 10 bit	
	[50.00Hz]	3840×2160	50.00p	[1920×1080p]: [1920×1080i]*:	1920×1080/50.00p 4:2:2 10 bit 1920×1080/50.00i 4:2:2 10 bit
			25.00p	[1920×1080p]: [1920×1080PsF]*:	1920×1080/25.00p 4:2:2 10 bit 1920×1080/25.00PsF 4:2:2 10 bit
		1920×1080	50.00p	[1920×1080p]: [1920×1080i]*:	1920×1080/50.00p 4:2:2 10 bit 1920×1080/50.00i 4:2:2 10 bit
			50.00i	[1920×1080i]:	1920×1080/50.00i 4:2:2 10 bit
25.00p			[1920×1080p]: [1920×1080PsF]*:	1920×1080/25.00p 4:2:2 10 bit 1920×1080/25.00PsF 4:2:2 10 bit	
1280×720		50.00p	[1280×720p]:	1280×720/50.00p 4:2:2 10 bit	

\* Factory setting

#### NOTE

- The 3840×2160 output is not supported.
- User bits are not displayed.
- [OUT FORMAT] restores the factory settings when the settings of [FREQUENCY] and [REC FORMAT] change and the current setting values of [OUT FORMAT] cannot be acquired.
- The output format when playing back from the thumbnail screen is as follows.
  - It will be the value set in [OUT FORMAT] when the recording resolution of the playback clip is the same as [REC FORMAT].
  - It will be factory setting of [OUT FORMAT] when the recording resolution of the playback clip is different from [REC FORMAT].
- There may be a few seconds of images not displayed on the external device when the clips are changing over, etc.

## Format that can be output from the <HDMI> terminal

The format that can be output from the <HDMI> terminal differs with following combination of the settings.

- [SYSTEM] menu → [FREQUENCY]
- [SYSTEM] menu → [FILE FORMAT]
- [SYSTEM] menu → [REC FORMAT]
- [VIDEO OUT/LCD/VF] menu → [HDMI OUT] → [OUT FORMAT]

Item			[OUT FORMAT]: Output Format	
[FREQUENCY]	[REC FORMAT]			
	Resolution	Frame rate		
[59.94Hz]	3840×2160	59.94p	[3840×2160p]:	3840×2160/59.94p 4:2:2 10 bit
			[3840×2160p(420/8bit)]:	3840×2160/59.94p 4:2:0 8 bit
			[1920×1080p] <sup>*1</sup> :	1920×1080/59.94p 4:2:2 10 bit
		[1920×1080i]:	1920×1080/59.94i 4:2:2 10 bit	
		29.97p	[3840×2160p]:	3840×2160/29.97p 4:2:2 10 bit
		[1920×1080p] <sup>*1</sup> :	1920×1080/29.97p 4:2:2 10 bit	
	23.98p	[3840×2160p]:	3840×2160/23.98p 4:2:2 10 bit	
	[1920×1080p] <sup>*1</sup> :	1920×1080/23.98p 4:2:2 10 bit		
	1920×1080	59.94p	[1920×1080p] <sup>*1</sup> :	1920×1080/59.94p 4:2:2 10 bit
			[1920×1080i]:	1920×1080/59.94i 4:2:2 10 bit
			[720×480p] <sup>*2</sup> :	720×480/59.94p 4:2:2 10 bit
		59.94i	[1920×1080i] <sup>*1</sup> :	1920×1080/59.94i 4:2:2 10 bit
[720×480p] <sup>*2</sup> :		720×480/59.94p 4:2:2 10 bit		
29.97p		[1920×1080p]:	1920×1080/29.97p 4:2:2 10 bit	
23.98p	[1920×1080p] <sup>*1</sup> :	1920×1080/23.98p 4:2:2 10 bit		
[720×480p] <sup>*2</sup> :	720×480/23.98p 4:2:2 10 bit			
1280×720	59.94p	[1280×720p] <sup>*1</sup> :	1280×720/59.94p 4:2:2 10 bit	
[720×480p] <sup>*2</sup> :	720×480/59.94p 4:2:2 10 bit			
[50.00Hz]	3840×2160	50.00p	[3840×2160p]:	3840×2160/50.00p 4:2:2 10 bit
			[3840×2160p(420/8bit)]:	3840×2160/50.00p 4:2:0 8 bit
			[1920×1080p] <sup>*1</sup> :	1920×1080/50.00p 4:2:2 10 bit
		[1920×1080i]:	1920×1080/50.00i 4:2:2 10 bit	
		25.00p	[3840×2160p]:	3840×2160/25.00p 4:2:2 10 bit
		[1920×1080p] <sup>*1</sup> :	1920×1080/25.00p 4:2:2 10 bit	
	1920×1080	50.00p	[1920×1080p] <sup>*1</sup> :	1920×1080/50.00p 4:2:2 10 bit
			[1920×1080i]:	1920×1080/50.00i 4:2:2 10 bit
			[720×576p] <sup>*2</sup> :	720×576/50.00p 4:2:2 10 bit
		50.00i	[1920×1080i] <sup>*1</sup> :	1920×1080/50.00i 4:2:2 10 bit
		[720×576p] <sup>*2</sup> :	720×576/50.00p 4:2:2 10 bit	
		25.00p	[1920×1080p]:	1920×1080/25.00p 4:2:2 10 bit
1280×720	50.00p	[1280×720p] <sup>*1</sup> :	1280×720/50.00p 4:2:2 10 bit	
[720×576p] <sup>*2</sup> :	720×576/50.00p 4:2:2 10 bit			

\*1 Factory setting

\*2 Can be selected when [FILE FORMAT] is [AVCHD].

### NOTE

- [OUT FORMAT] restores the factory settings when the settings of [FREQUENCY] and [REC FORMAT] change and the current setting values of [OUT FORMAT] cannot be acquired.
- The output format when playing back from the thumbnail screen is as follows.
  - It will be the value set in [OUT FORMAT] when the recording resolution of the playback clip is the same as [REC FORMAT].
  - It will be factory setting of [OUT FORMAT] when the recording resolution of the playback clip is different from [REC FORMAT].
- When either [720×480p] or [720×576p] is selected, images are output compressed horizontally so that they fit within the screen.
- There may be a few seconds of images not displayed on the external device when the clips are changing over, etc.

## Screen status display

### Screen display during shooting

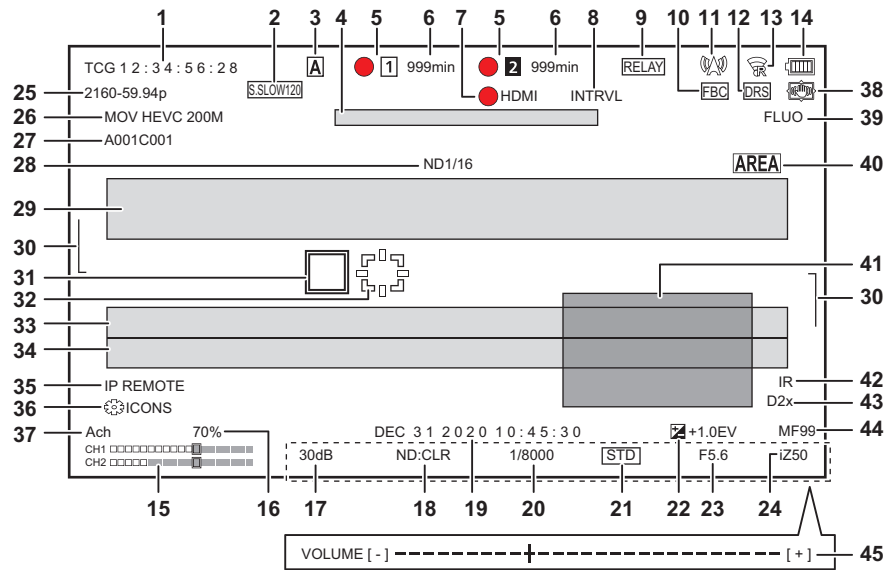

\*1 Displayed when using **X2000**.

\*2 The tally lamp is available when the handle unit (**X2000** supplied, **X1500** optional) is attached.

#### 1 Time code

Each time you press the USER button assigned to [COUNTER] or touch the USER button icon, the next display is shown or it switches to no display.

- **[TCG \*\*:\*\*\*:\*\*\*:]**: Displays the time code. [TCR \*\*:\*\*\*:\*\*\*:] will be displayed during playback.
- **[UBG \*\* \* \* \* \* \*]**: Displays the user bits. [UBR \*\* \* \* \* \* \*] will be displayed during playback.
- **[CLIP \*\*:\*\*\*:\*\*\*:]**: Displays the counter value of each clip. This is displayed when the [RECORDING] menu → [REC COUNTER] is set to [CLIP]. Displays the counter value of the clip being played back during playback.
- **[\*:\*\*\*:\*\*\*:]**: Displays the cumulative counter value from the reset position. This is displayed when the [RECORDING] menu → [REC COUNTER] → [TOTAL] is set.

#### 2 Frame rate

- **[S.SLOW120]**: Displayed when set to the [SYSTEM] menu → [SUPER SLOW] → [ON] and the [SYSTEM] menu → [FREQUENCY] → [59.94Hz].
- **[S.SLOW100]**: Displayed when set to the [SYSTEM] menu → [SUPER SLOW] → [ON] and the [SYSTEM] menu → [FREQUENCY] → [50.00Hz].
- **(No display)**: It is not displayed when set to the [SYSTEM] menu → [SUPER SLOW] → [OFF].

#### 3 <AUTO/MANU> switch

Displayed when the <AUTO/MANU> switch is set to <AUTO>.

#### 4 Message display area for stop of cooling fan

Displays a message when the cooling fan has stopped.

#### 5 Recording status

Displays the recording status of the memory card in card slot 1 or card slot 2.

- **1, 2**: Not target for recording.
- **1 (flashing), 2 (flashing)**: Recognizing the memory card.
- **1, 2**: The recording is stopped while the recording target memory card is inserted.
- **1, 2**: Recording.
- **1 (Flashing red dot), 2 (Flashing red dot)**: Processing to stop the recording.
- **[P 1], [P 2]**: Recording is stopped with pre-recording is enabled and the recording target memory card is inserted.
- **(No display)**: It is in one of the following conditions.
  - A memory card has not been inserted.
  - The memory card cannot be recognized.

The following indicators are displayed in card slot 1 only.

- **[P]**: Pre-recording is enabled, and the memory card is not inserted in the card slot, or the memory card is not recognized.
- **●**: The tally lamp is instructed to illuminate in red via network.\*2
- **●**: The tally lamp is instructed to illuminate in green via network while the recording is stopped. The tally lamp on the handle unit does not illuminate green.\*2

**6 Remaining recording capacity and status of the memory card**

Displays the remaining recording capacity and status of the memory card in card slot 1 or card slot 2.

- **[0min] to [999min]:** Remaining recording capacity (999 minutes or more is displayed as [999min])
  - The display will flash when the remaining recording capacity becomes 2 minutes or less.
  - The recording capacity available for simultaneous recording (recording capacity for the memory card of the 2 memory cards with less recording capacity) is displayed when simultaneous recording is performed.
- **[WPP]:** Write protected (the write protection switch of the memory card is set to the LOCK side)
- **[END]:** No remaining recording capacity (no remaining recording capacity on the memory card)
- **[ERR]:** A memory card that cannot record is inserted (the card is recognized but cannot record due to a format error, a card other than a memory card being inserted, etc.)
- **[SDXC]:** An SDXC memory card is not inserted in MOV recording/MP4 recording
- **(No display):** It is in one of the following conditions.
  - A memory card has not been inserted.
  - The memory card cannot be recognized.

**7 External equipment recording operation control status (<SDI OUT>/<HDMI> terminal)**

Displays the control status of the recording start and recording stop on the external equipment connected to the <SDI OUT> terminal and the <HDMI> terminal.

- **[●SDI]\*1:** Recording instruction is output to the output from the <SDI OUT> terminal.
- **[SDI]\*1:** Pause instruction is output to the output from the <SDI OUT> terminal.
- **[●HDMI]:** Recording instruction is output to the output from the <HDMI> terminal.
- **[HDMI]:** Pause instruction is output to the output from the <HDMI> terminal.

**8 Special recording function**

Displays the status of special recording function.

- **[INTRVL]:** The interval recording is stopped.
- **[I-REC]:** The interval recording is in progress. (Displayed in red)

**9 2-slot function**

Displays the setting status of the recording function using 2 memory cards.

It is displayed with a slanted line if it is in a condition that cannot perform 2-slot recording even if each function is enabled.





- **[RELAY]:** When the relay recording is enabled
- **[SIMUL]:** When the simultaneous recording is enabled
- **[BACKGR]:** When the background recording is enabled
- **(No display):** During standard recording

**10 Flash band compensation function**

- **[FBC]:** Displayed when the flash band compensation function is operating.

**11 Streaming status**

Displays the streaming status.



- : When the unit is connected to a device to receive the streaming video, and the streaming video is distributed
-  **(flashing):** When the unit is being connected to a device to receive the streaming video
- : When the streaming function is enabled, it is in condition to operate properly, and the streaming video is not distributed
- : When there is an error in the streaming function and cannot operate
- **(No display):** When the streaming function is disabled

**12 Dynamic range stretcher function**







- **[DRS]:** Displays when the dynamic range stretcher function is working.

**13 Connection status of the wireless LAN**

Displays the connection status of the wireless LAN.

- : When set to the wireless LAN and the ROP is not connected
- : When set to the wireless LAN and the ROP is connected
- : When set to the wireless LAN and the wireless LAN is not operating properly
- **(No display):** When the wireless LAN is disabled

**14 Power status**

: Displays the remaining battery level while powered with the battery. (The battery status display will change as  →  →  →  →  while the remaining battery level gets lower. It will flash in red when the remaining battery level is zero.)

: Displayed when powered with the AC adaptor.

**15 Audio level meter**

Displays the audio level meter.

A white border is displayed in the position of the recording base level (12 dB).

- : Displayed when audio cannot be recorded. (When super slow is enabled, etc.)

**16 Luminance of Y GET**

Displays the luminance level in 0% through 109% when the Y GET function is operating.

**17 Gain**

Displays the gain value.

- **[AGC]:** Displayed when the auto gain control is operating.
- **[SG]:** Displayed when [SUPER GAIN] is working.
- **[SG+]:** Displayed when [SUPER GAIN+] is working.



## 18 ND filter

Displays the transmittance of the selected ND filter.

- **[ND1/64]**: Reduces the amount of light entering the MOS sensor to 1/64.
- **[ND1/16]**: Reduces the amount of light entering the MOS sensor to 1/16.
- **[ND1/4]**: Reduces the amount of light entering the MOS sensor to 1/4.
- **[ND:CLR]**: The ND filter is not used.

## 19 Date and time information

Displays the date and time information. It is not displayed when the time stamp function is enabled.

The display contents follow the setting in the [VIDEO OUT/LCD/VF] menu → [INDICATOR] → [DATE/TIME]. (→ 80)

The display order for the year, month, and date follows the setting in the [OTHERS] menu → [CLOCK] → [DATE FORMAT].

Displays in the yyyy mmm dd hh:mm:ss format when set to [Y-M-D].

Displays in the mmm dd yyyy hh:mm:ss format when set to [M-D-Y].

Displays in the dd mmm yyyy hh:mm:ss format when set to [D-M-Y].

- **mmm**: Month (JAN (January), FEB (February), MAR (March), APR (April), MAY (May), JUN (June), JUL (July), AUG (August), SEP (September), OCT (October), NOV (November), DEC (December))
- **dd**: Date
- **yyyy**: Year
- **hh**: Hour
- **mm**: Minute
- **ss**: Second

## 20 Shutter speed

Displays the shutter speed.

This is not displayed when the shutter function is disabled.

- **[A.SHTR]**: Displayed when the auto shutter is operating.

## 21 Auto iris control status

Displays the control status of the auto iris.

- **[STD]**: Standard auto iris control
- **[SPOT]**: Auto iris control for spot light
- **[BACK]**: Auto iris control for the backlight compensation

## 22 AE level

Displays the exposure compensation value.

## 23 Iris

Displays the iris value.

## 24 Zoom

Displays the zoom value.

The display of the zoom value follows the setting in the [VIDEO OUT/LCD/VF] menu → [INDICATOR] → [ZOOM/FOCUS].

Displays in the position value from [00] to [99] when set to [NUMBER].

Displays in millimeter unit when set to [mm/feet] or [mm/m].

Displays [i] when [i.ZOOM] is enabled.

[i] is displayed with black and white inverted when [i.ZOOM] is operating.

[Z] is displayed with black and white inverted when [FAST ZOOM] is enabled.

## 25 System resolution/system frequency

Displays the system resolution and the system frequency set in the [SYSTEM] menu → [REC FORMAT].

- [2160-59.94p], [2160-50.00p], [2160-29.97p], [2160-25.00p], [2160-23.98p], [1080-59.94p], [1080-50.00p], [1080-29.97p], [1080-25.00p], [1080-23.98p], [1080-59.94i], [1080-50.00i], [720-59.94p], [720-50.00p]

## 26 Recording format

Displays the file format and the recording codec set in the [SYSTEM] menu → [FILE FORMAT] and [REC FORMAT].

- [MOV 420 150M], [MOV 420 100M], [MOV 422 150M], [MOV 422 100M], [MOV 422 50M], [MOV HEVC 200M], [MOV HEVC 150M], [MOV HEVC 100M], [MOV ALL-I 200M], [MOV ALL-I 100M]
- [MP4 420 72M], [MP4 420 50M], [MP4 HEVC 100M], [MP4 HEVC 72M]
- [AVCHD PS], [AVCHD PH], [AVCHD HA], [AVCHD PM]

## 27 Clip name

Displays the name of the clip being recorded with up to 8 characters from the beginning.

## 28 Recommended ND filter

Displays the ND filter recommended in the current shooting condition.

## 29 Message display area

Displays messages, such as the status of the camera and warnings.

Displays the warning status of the unit in the STATUS screen for the mode check.

## 30 Level gauge

Tilt in horizontal direction or vertical direction can be checked.

- This is not output externally to the TV/monitor. View it on the LCD monitor/viewfinder of this unit.

## 31 Main face frame (orange)/Face detection frame (white)

Displayed when a face has been detected while the face detection AE&AF function is operating.

## 32 Tracking frame (green)

Displayed when a subject has been touched while the face detection AE&AF function is operating. The function switches to the tracking AE&AF function.

## 33 Error display of auto white balance

Displays the error status of the auto white balance.

**34 Error display of auto black balance**

Displays the error status of the auto black balance.

**35 Remote control status in an IP connection**

- **[IP REMOTE]**: Displayed when the remote control is possible in the IP connection.
- **[IP REMOTE] (flashing)**: Displayed when waiting for the connection in the IP connection.

**36 Multi manual function**



Displays the contents of the multi manual function. For details, refer to “Multi manual function” (→ 143).

**37 Color temperature**

Displays the position and color temperature selected with the <WHITE BAL> button.  
This is not displayed when IR recording is enabled.

- **[ATW]**: Displayed when the auto tracking white balance is operating.
- **[LOCK]**: Displayed when the auto tracking white balance is locked.

**38 Optical image stabilizer function**

- : Displayed when the optical image stabilizer function is operating.
- : Displayed when the hybrid optical image stabilizer function is operating.

**39 Scene file name**

Displays the name of the selected scene file.

**40 Area mode function, face detection/tracking AE&AF function**

- **[AREA]**: Displayed when the area mode function is operating.
- **[FACE]**: Displayed when the face detection AE&AF function is working.
- **[TRACK]**: Displayed when the tracking AE&AF function is working.

**41 Waveform monitor**

Displays the video status in waveform or vector.

- This is not output externally to the TV/monitor. View it on the LCD monitor/viewfinder of this unit.

**42 IR recording**

- **[IR]**: Displayed when the IR recording is enabled.

**43 Digital zoom**

Displays the digital zoom ratio.

- **[D2×]**: 2 times
- **[D5×]**: 5 times
- **[D10×]**: 10 times

**44 Focus**

Displays the focus value.

The display of the focus value follows the setting in the [VIDEO OUT/LCD/VF] menu → [INDICATOR] → [ZOOM/FOCUS].

Displays in the position value from [00] to [99] when set to [NUMBER].

Displays in feet unit when set to [mm/feet].

Displays in meter unit when set to [mm/m].

- **[AF]**: Displayed when set to auto focus mode.
- **[MF]**: Displayed when set to manual focus mode.

**45 Audio monitor volume adjustment**

Displayed when the zoom lever (on the grip) or the multial is used to adjust the volume of the speaker or headphones. The display is cleared approximately 3 seconds after the operation.

## Screen display during playback

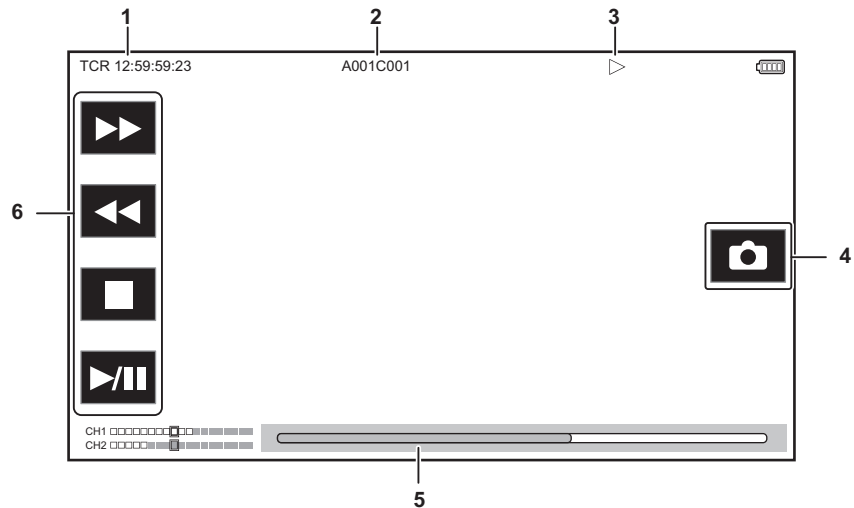
**1 Time code display**

Each time you press the USER button assigned to [COUNTER], the display changes in the order [TCR \*\*:\*\*:\*\*:\*\*:\*\*], [UBR \*\* \*\* \* \* \* \* \*\*], [CLIP \*\*:\*\*:\*\*:\*\*:\*\*], no display.

**2 Clip name**

Displays the name of the clip being played back with up to 8 characters from the beginning.

**3 Playback status**

Displays the status of playback.  
Displays only during playback.

- ■ : Stop
- ► : Playback
- || : Pause
- ◀ : Frame-by-frame rewind
- ▶ : Frame-by-frame
- ►► : Fast-forward playback (10× speed)
- ►►► : Fast-forward playback (20× speed)
- ◀◀ : Fast-reverse playback (10× speed)
- ◀◀◀ : Fast-reverse playback (20× speed)
- ▶ : Slow playback
- ◀ : Reverse slow playback

**4 Still picture recording icon**

Touching the icon while playing back or while paused records the scene as a still picture.

**5 Direct playback bar**

Displays the general position that is being played back.

**6 Playback navigation icon**

Operates by touching the icon.

- ►► : Fast-forward playback
- ◀◀ : Fast-reverse playback
- ■ : Stop
- ►/|| : Playback/pause

## Checking and displaying shooting status

The screen to check the setting and status of the unit can be displayed.

Press the <DISP/MODE CHK> button while the camera image screen is displayed to hide most of the items.

Press the <DISP/MODE CHK> button for 1 second or more while the camera image screen is displayed to display the STATUS screen of the mode check and check the shooting status.

For details about each item that can be displayed in the mode check, refer to “Mode check display” (→ 165).

The following table indicates each item to display/hide in each screen.

- “✓” indicates displaying and “—” indicates hiding.
- You can select to display or hide each item in the [VIDEO OUT/LCD/VF] menu → [INDICATOR].

\*1 This is not displayed in the status where ●/● is not displayed.

\*2 Displays when the remaining recording capacity of the memory card or remaining battery level gets low.

\*3 The display position differs in the playback screen. Refer to “Screen display during playback” (→ 163).

\*4 Displays when the multidual is pressed. The display is cleared approximately 3 seconds after the operation.

No	Item	Camera image screen	When the <DISP/MODE CHK> button is pressed	STATUS	Playback screen
1	Time code	✓	✓	✓	✓
2	Frame rate	✓	—	✓	—
3	<AUTO/MANU> switch	✓	—	✓	—
4	Message display area for stop of cooling fan	✓	✓	✓	✓
5	Recording status	✓	✓*1	✓	—
6	Remaining recording capacity and status of the memory card	✓	—*2	✓	—
7	External equipment recording operation control status (<SDI OUT>/<HDMI> terminal)	✓	—	✓	—
8	Special recording function	✓	—	✓	—
9	2-slot function	✓	—	✓	—
10	Flash band compensation function	✓	—	✓	—
11	Streaming status	✓	—	✓	—
12	Dynamic range stretcher function	✓	—	✓	—
13	Connection status of the wireless LAN	✓	—	✓	—
14	Power status	✓	—*2	✓	✓
15	Audio level meter	✓	—	✓	✓
16	Luminance of Y GET	✓	✓	✓	—
17	Gain	✓	—	✓	—
18	ND filter	✓	—	✓	—
19	Date and time information	✓	—	✓	—
20	Shutter speed	✓	—	✓	—
21	Auto iris control status	✓	—	✓	—
22	AE level	✓	—	✓	—
23	Iris	✓	—	✓	—
24	Zoom	✓	—	✓	—
25	System resolution/system frequency	✓	—	✓	—
26	Recording format	✓	—	✓	—
27	Clip name	✓	—	✓	✓*3
28	Recommended ND filter	✓	✓	✓	—
29	Message display area	✓	✓	✓	✓
30	Level gauge	✓	✓	✓	—
31	Main face frame (orange)/Face detection frame (white)	✓	✓	✓	—
32	Tracking frame (green)	✓	✓	✓	—
33	Error display of auto white balance	—	—	✓	—
34	Error display of auto black balance	—	—	✓	—
35	Remote control status in an IP connection	—	—	✓	—
36	Multi manual function	✓	—*4	✓	—
37	Color temperature	✓	—	✓	—
38	Optical image stabilizer function	✓	—	✓	—
39	Scene file name	✓	—	✓	—
40	Area mode function, face detection/tracking AE&AF function	✓	—	✓	—

No	Item	Camera image screen	When the <DISP/MODE CHK> button is pressed	STATUS	Playback screen
41	Waveform monitor	✓	✓	—	—
42	IR recording	✓	—	✓	—
43	Digital zoom	✓	—	✓	—
44	Focus	✓	—	✓	—
45	Audio monitor volume adjustment	✓	✓	✓	✓

## Mode check display

The unit's settings and status can be displayed on the viewfinder or LCD monitor screen for check.

Press the <DISP/MODE CHK> button for 1 second or more while displaying the camera image screen to display the STATUS screen of the mode check. Each time you press the <DISP/MODE CHK> button, the display switches in the order STATUS screen, FUNCTION screen, AUDIO screen, SWITCH screen, NETWORK screen, camera image screen.

Each screen of the mode check is displayed for approximately 5 seconds.

The screen does not switch while the <DISP/MODE CHK> button is pressed.

Press the <EXIT> button while each screen is displayed to return to the camera image screen.

### NOTE

- The mode check screen cannot be displayed even when you press the <DISP/MODE CHK> button in the following case:
  - When the [VIDEO OUT/LCD/VF] menu → [LCD] → [SELF SHOOT] → [MIRROR] is set and the LCD monitor is rotated toward the lens (when mirror shooting)

## FUNCTION screen

Displays the video output settings and information of the recording media.

\*1 Displayed when using **X2000**.

Item	Description
[SDI OUT]*1	[VIDEO OUT FORMAT] Displays with [1920×1080p]/[1920×1080i]/[1920×1080PsF]/[1280×720p] the signals output through the <SDI OUT> terminal.
	[VIDEO OUT CHAR] Displays with [ON]/[OFF] whether the characters output through the <SDI OUT> terminal are superimposed.
[HDMI OUT]	[VIDEO OUT FORMAT] Displays with [3840×2160p]/[3840×2160p(420/8bit)]/[1920×1080p]/[1920×1080i]/[1280×720p]/[720×480p]/[720×576p] the signals output through the <HDMI> terminal.
	[VIDEO OUT CHAR] Displays with [ON]/[OFF] whether the characters output through the <HDMI> terminal are superimposed.
[CARD STATUS]	— Displays the status, remaining recording capacity, and the total capacity of the memory card inserted in the card slot. The status of the memory card that is displayed are following types. <ul style="list-style-type: none"> <li>• [NO CARD]: Memory card is not inserted.</li> <li>• [UNSUPPORTED]: Memory card is not supported.</li> <li>• [FORMAT ERROR]: Memory card cannot be used. (Format error)</li> <li>• [PROTECTED]: It is write protected. (The write-protection switch of the memory card is set to the LOCK side)</li> <li>• [NO REMAIN]: There is no remaining recording capacity.</li> <li>• [NOT SDXC]: SDXC memory card is not inserted in the MOV recording/MP4 recording.</li> <li>• Cases other than above: The remaining recording capacity is displayed in 0% through 100%.</li> </ul>
	[TOTAL] Displays the remaining recording capacity/total capacity of the memory cards in the card slot 1 and the card slot 2.
	[SLOT1] Displays the status and remaining recording capacity/total capacity of the memory card in card slot 1.
	[SLOT2] Displays the status and remaining recording capacity/total capacity of the memory card in card slot 2.

**AUDIO screen**

Displays the audio input/output settings and the audio level meter.

Item		Description	
[HANDLE]	[HANDLE STATUS]	Displays with [ATTACHED]/[DETACHED] whether the handle unit ( <b>X2000</b> supplied, <b>X1500</b> optional) is attached.	
[AUDIO]	[SOURCE]	[CH1] to [CH2]	Displays the audio recorded to each channel. <ul style="list-style-type: none"> <li>When the handle unit is attached <ul style="list-style-type: none"> <li>[CH1]: [INT(L)]/[MIC(L)]/[INPUT1(MIC)]/[INPUT1(LINE)]/[INPUT1(MIC+48V)]</li> <li>[CH2]: [INT(R)]/[MIC(R)]/[INPUT1(MIC)]/[INPUT1(LINE)]/[INPUT1(MIC+48V)]/[INPUT2(MIC)]/[INPUT2(LINE)]/[INPUT2(MIC+48V)]</li> </ul> </li> <li>When the handle unit has not been attached <ul style="list-style-type: none"> <li>[CH1]: [INT(L)]/[MIC(L)]</li> <li>[CH2]: [INT(R)]/[MIC(R)]</li> </ul> </li> </ul>
	[LEVEL]	[CH1] to [CH2]	Displays the adjustment method of the recording level of the audio for each channel with [AUTO]/[MANU].
	[LIMITER]	[CH1] to [CH2]	Displays enable/disable of limiter for each channel with [ON]/[OFF]. Displays [---] when the adjustment method of the recording level of the audio is set to [AUTO].
	[LOWCUT]	[CH1] to [CH2]	Displays enable/disable of low-cut filter for each channel with [ON]/[OFF].
	Audio level meter		Enlarges the display of the audio level meter displayed on the camera image screen.
	[AUDIO OUT]		Displays with [CH1]/[CH2]/[CH1/2 STEREO]/[CH1/2 MIX] the audio channel format output from the headphone jack and the built-in speaker.

**SWITCH screen**

Displays the values assigned to the USER switch, super gain, and white balance.

Item		Description
[USER SW]	[1] to [5]	Displays the function assigned to <USER1> through <USER5> buttons.
[OTHER ASSIGN]	[S.GAIN]	Displays the list of gain values assigned as a super gain.
	[WHITE BAL A]	Displays the setting status of the [Ach] of the white balance as either [OK] or [NG]. Displays [ATW] when the auto tracking white balance function is assigned.
	[WHITE BAL B]	Displays the setting status of the [Bch] of the white balance as either [OK] or [NG]. Displays [ATW] when the auto tracking white balance function is assigned.
	[WHITE BAL PRST]	Displays the color temperature assigned to the "preset" of white balance. Displays [ATW] when the auto tracking white balance function is assigned. Color temperature and [VAR] are displayed when "VAR" is assigned.

**NETWORK screen**

Displays the settings of the network function.

Item		Description
[NETWORK]	[DEVICE SEL]	Displays the device used for network connection in [WLAN] (wireless LAN)/[OFF].
	[NETWORK FUNC]	Displays the network function of the unit with [STREAMING]/[OFF].
	[STRM FORMAT]	Displays the streaming format. It is not displayed when set to the [NETWORK] menu → [NETWORK FUNC] → [OFF].
	[IP REMOTE]	Displays enable/disable of the IP remote function with [ENABLE]/[DISABLE].
	[IPv4 ADDRESS]	Displays the IP address of IPv4. It is not displayed when set to the [NETWORK] menu → [DEVICE SEL] → [OFF].

## Chapter 8 **Connecting to External Devices**

---

This chapter describes the external devices that can be connected to the unit.

## Connecting with headphones and TV/monitor

### Headphones

Headphones (commercially-available) can be connected to the headphone terminal (3.5 mm (0.14") diameter stereo mini jack).

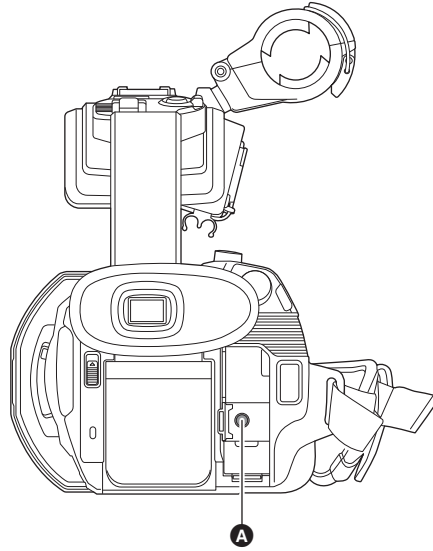

**A** Headphone terminal

#### **NOTE**

- Audio is not output from the built-in speaker when headphones are connected to the headphone terminal.

### Remote control

Connect the remote control unit (commercially-available) to the <REMOTE> terminal (2.5 mm (0.1") diameter super mini jack) to operate some of the functions remotely.

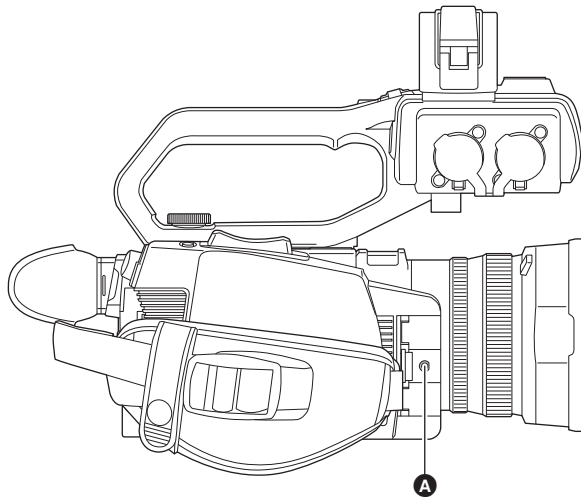

**A** <REMOTE> terminal



## TV/monitor

A TV or monitor can be connected as shown in the following figure.

- When using **X2000**, use a BNC cable (<SDI OUT> terminal) to connect a TV/monitor.

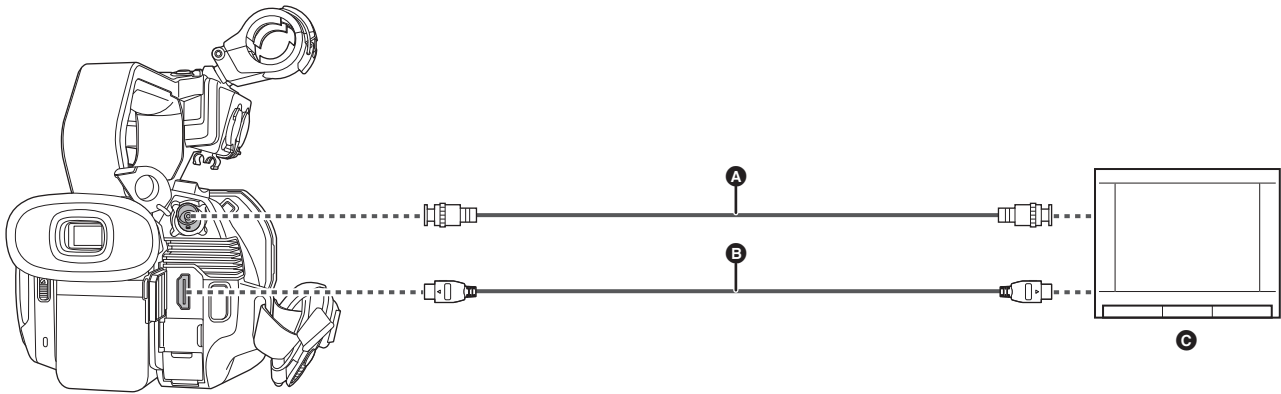

- A** (For the **X2000**)  
BNC cable (commercially-available)
- B** HDMI cable (commercially-available)
- C** TV/Monitor

- By connecting this unit to a 4K video compatible TV/monitor using an HDMI cable, and playing back clips recorded with a recording format that has a resolution of UHD (3840×2160), you can enjoy the finely detailed video provided by 4K videos. If the TV/monitor is not compatible with 4K video, you can set [OUT FORMAT] and reduce the output resolution for playback. (→ 158)

### NOTE

**When using a DVI converter, etc., to connect an HDMI cable to this unit, make sure that you connect last to the <HDMI> terminal on this unit. Connecting first to the <HDMI> terminal on this unit may cause a malfunction.**

- VIERA Link is not supported on the unit. Note that the VIERA Link of other device may not properly operate when connected to the VIERA Link compatible device with a HDMI cable (commercially-available).
- The SD resolution signal output from the <HDMI> terminal is output as a progressive signal (480P, 576P).
- (For the **X2000**)  
Use a commercially-available 5C-FB or equivalent double-shielded cable for the BNC cable.
- Use a commercially-available High Speed HDMI cable. If possible, we recommend using a cable with a length of 3 m (approx. 9.8 feet) or less.
- When this unit is connected to a TV/monitor while displaying the camera image screen, there may be some howling\* caused. Press the <THUMBNAIL> button to switch to the thumbnail screen first before connecting this unit to a TV/monitor.
- \* The microphone can pick up the sounds coming from the speaker which can cause unusual sounds.

## Connection function via the USB terminal

### Connection with a computer in card reader mode

Connect the unit to a computer via the USB cable to use the unit as a card reader for the memory card.

- This unit supports USB2.0.

### Connecting to a computer

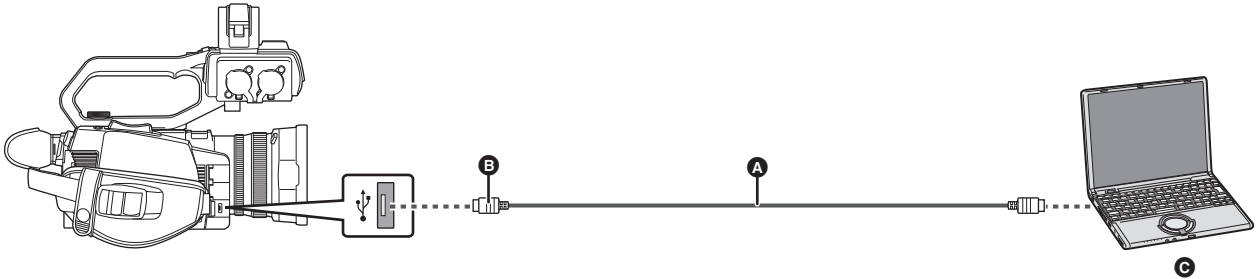

- A** USB cable (commercially-available)
- B** Micro-B
- C** Computer

#### 1 Connect the USB cable to the USB terminal.

#### 2 Select the [OTHERS] menu → [USB DEVICE] → [CARD READER MODE] → [YES].

During USB connection, [USB connected. Please operate via PC.] is displayed in the center of the viewfinder or LCD monitor.

If the USB connection is being moved or it is not connected properly, [Connect this unit to PC using USB cable.] is displayed.

- When using the battery, the LCD monitor turns off after about 5 seconds. Touch the screen to turn the LCD monitor on.

#### 3 Exit the card reader mode.

There are following methods.

- Turn off the unit.
- Press the <EXIT> button.
- Press the multial.
- Touch [↶]

After exiting the card reader mode, returns to camera shooting status in approximately 5 seconds.

#### NOTE

- You can also either press the USER button assigned to [CARD READER MODE] or touch the USER button icon to switch to the card reader mode.
- A USB cable is not supplied with this unit. Use a commercially-available generic USB cable conforming to USB2.0. If possible, we recommend using a cable with a length of 1.5 m (approx. 4.9 feet) or less.
- You cannot write data to the memory cards of this unit from a computer.
- When connecting the unit to a computer via USB, ensure that no other device is connected to the computer via USB.
- Do not remove the memory card when connecting the unit via USB.
- The card access lamp while connected to USB will turn off unless accessing.
- When the unit is operating in the card reader mode, it cannot perform shooting, recording, and playback, and thumbnail operations cannot be performed on clips.
- When the unit is operating in the card reader mode, the remaining recording capacity and status of the memory card are not displayed. Also, video/audio cannot be output or displayed.
- The LCD monitor lights up by touching the monitor if it has turned out to save energy.
- When reading or writing the data on a memory card with a computer, the SD card slot in the computer or the SD card reader/writer you are using may not support the memory card.
- When the unit is connected to a computer, it is recognized as an external drive.  
It is displayed on a computer as a removable drive (for example:  A001 (F:)).
- For example memory card folder structures, refer to page 44.

**To disconnect USB cable safely****■ For Windows**

**1** On the screen of the computer, select the  icon in the task tray, then deselect the model number of this unit. (For example: “HC-X2000”, etc.)

- Depending on your computer's settings, this icon may not be displayed.

**■ For Mac**

**1** Move the icon of the volume name of the memory card (for example: “A001”, etc.) displayed on the desktop to [Trash], then disconnect the USB cable.

**About the screen indication of the unit**

- The card 1 access lamp or card 2 access lamp flashes while this unit is being accessed. Do not disconnect the USB cable, battery, or AC adaptor while the unit is being accessed.
- If the screen does not change when the unit is operated while connected to a computer, disconnect the battery and/or AC adaptor, wait approximately 1 minute, reconnect the battery and/or AC adaptor, wait approximately 1 minute again, and then turn the unit back on. (Data may be destroyed when above operation is performed while accessing the memory card.)

**Operating environment (mass storage)**

- Even if the system requirements mentioned in this owner's manual are fulfilled, some computer's cannot be used.
- The USB equipment operates with the driver installed as standard in the OS.

**■ For Windows**

OS	Windows 10 (32 bit/64 bit) Windows 8.1 (32 bit/64 bit) Windows 7 (32 bit/64 bit) (SP1)
CPU	1 GHz or higher 32 bit (x86) or 64 bit (x64) processor
RAM	2 GB or more (64 bit)/1 GB or more (32 bit)
Interface	USB port
Other requirements	Mouse or equivalent pointing device

**■ For Mac**

OS	macOS v10.15
CPU	Intel Core 2 Duo or better
RAM	2 GB or more
Interface	USB port
Other requirements	Mouse or equivalent pointing device

## Remote operation by iPhone/iPad or Android terminal

---

This unit can connect to wireless LAN devices via a network.

Some of the functions can be remotely operated by connecting the unit with iPhone/iPad or Android terminal with the HC ROP app installed. (→ 178)

## Chapter 9

# Network Connection

---

This chapter describes how to use the unit by connecting to a network.

## Network connection

This unit is equipped with wireless LAN. It can connect to networks via wireless LAN.

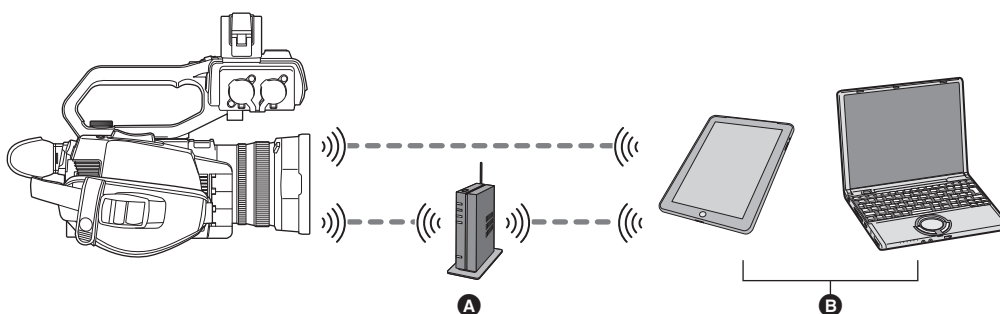

- A** Wireless access point
- B** Device with wireless LAN

### Available functions

When the unit is connected to a network, the following functions are available.

- Connecting to HC ROP app
- Streaming function

### About the wireless LAN function on this unit

#### ■ Use this unit as a wireless LAN device

When using equipment or computer systems that require more reliable security than wireless LAN devices, ensure that the appropriate measures are taken for safety designs and defects for the systems used. Panasonic will not take any responsibility for any damage that arises when using this unit for any purpose other than as a wireless LAN device.

#### ■ Use of the wireless LAN function of this unit is presumed to be in countries where this unit is sold

There is the risk that this unit violates the radiowave regulations if used in countries other than those where this unit is sold, and Panasonic takes no responsibility for any violations.

#### ■ There is the risk that data sent and received via radio waves may be intercepted

Please note that there is the risk that data sent and received via radio waves may be intercepted by a third party.

#### ■ Do not use this unit in areas with magnetic fields, static electricity or interference

- Do not use this unit in areas with magnetic fields, static electricity or interference, such as near microwave ovens. Radio waves may not reach this unit.
- Using this unit near devices such as cordless telephones or any other wireless LAN device that use the 2.4 GHz radio wave band may cause a decrease in performance in both devices.

#### ■ Do not connect to the wireless network you are not authorised to use

When this unit utilises its wireless LAN function, wireless networks will be searched automatically. When this happens, wireless networks that you are not authorised to use (SSID\*) may be displayed, however do not attempt to connect to the network as it may be considered as unauthorised access.

\* SSID refers to the name of device that is used to identify a network over a wireless LAN connection. If the SSID matches for both devices, transmission is possible.

#### ■ Before use

To use the wireless LAN function on this unit, you need a wireless access point or a device connected that has wireless LAN functionality.

For the operations and settings of the device you are using, such as iPhone/iPad or Android handset, refer to the operating instructions for your device.

#### ■ This unit is WPS-compatible

WPS (Wi-Fi Protected Setup™) is a function that allows you to easily set up a connection with a wireless LAN device and make security-related settings.

#### NOTE

- This unit cannot be connected to wireless LAN devices via public wireless LAN environments.
- The wireless access point must be compatible with IEEE802.11b, IEEE802.11g, or IEEE802.11n.
- This unit uses the 2.4 GHz frequency band. You cannot establish a wireless LAN connection using the 5 GHz frequency band.
- When using a wireless access point, we strongly recommend that you set an encryption to maintain information security.
- Depending on the signal status, it may not be possible to connect to wireless LAN devices via a network.
- If the wireless LAN connection is not working well, set up so the wireless LAN transmitter (→ 22) faces towards the wireless LAN device.
- When the battery indicator () is flashing red, the connection with other equipment may not start or the connection may be disrupted.
- When you are using the wireless LAN function of this unit, the wireless LAN transmitter (→ 22) may become warm but this does not indicate a malfunction.

## Network settings

### Wireless LAN settings

This is the setting to connect with the iPhone/iPad or the Android terminal directly or to connect to the wireless access point via wireless LAN.

#### Direct connection ([DIRECT])

This is the setting to connect the unit to the iPhone/iPad or Android terminal directly.

The unit may restart if necessary when the setting is changed.

**1** Select the [NETWORK] menu → [DEVICE SEL] → [WLAN].

**2** Select the [NETWORK] menu → [WLAN PROPERTY] → [TYPE] → [DIRECT].

**3** Select the [NETWORK] menu → [WLAN IPv4 SETTING] → [DHCP] → [SERVER].

When the DHCP server function of this unit is not to be used, select [OFF].

**4** In the [NETWORK] menu → [WLAN PROPERTY] and [WLAN IPv4 SETTING], set each item as necessary.

- For the setting items, refer to “Setting items for [WLAN PROPERTY] and [WLAN IPv4 SETTING] when set to [DIRECT]” (→ 175).

**5** Select the SSID of the unit from the SSID list in the iPhone/iPad or Android terminal, and enter the password (encryption key).

Display the wireless access point list screen in wireless LAN setting, and select SSID of the unit.

- Factory setting: The model number of the unit you are using is set. (For example: [HC-X2000], etc.)

When the password confirmation screen appears, enter the password (encryption key).

For details, refer to the operating instruction of the iPhone/iPad or Android terminal.

- Factory setting: [01234567890123456789abcdef]

**6** Close the menu or return to the level of the [NETWORK] menu.

**7** Check the network connection.

Once connected,  is displayed on the screen of the unit.

#### ■ Setting items for [WLAN PROPERTY] and [WLAN IPv4 SETTING] when set to [DIRECT]

[WLAN PROPERTY]	[SSID]	Network name of the unit (SSID) (Factory setting: The model number of the unit you are using is set. (For example: [HC-X2000], etc.))
	[CHANNEL]	Channel used (Factory setting: [AUTO])
	[ENCRYPT KEY]	WPA2 encryption key (Factory setting: [01234567890123456789abcdef])
[WLAN IPv4 SETTING]	[DHCP]	Setting the DHCP function <ul style="list-style-type: none"> <li>• [OFF]: Does not use DHCP.</li> <li>• [SERVER]: Enables the DHCP server function of the unit.</li> </ul> (Factory setting: [OFF])
	[IP ADDRESS]	IP address of the unit (Factory setting: [192.168.0.1])
	[SUBNET MASK]	Subnet mask (Factory setting: [255.255.255.0])

- When [DIRECT] is set, the following menu settings are automatically set and cannot be changed:

- [WLAN IPv4 SETTING] → [DEFAULT GATEWAY]
- [WLAN IPv4 SETTING] → [PRIMARY DNS]
- [WLAN IPv4 SETTING] → [SECONDARY DNS]

#### NOTE

- The startup time after turning on the power may be longer due to starting of the network.
- When changing the settings of [DEVICE SEL], the changes will not be reflected until the unit is restarted. Also, the setting screen termination may take some time due to the restart of the network service after the setting is changed.
- Some of the items not included in the table cannot be set.
- [ENCRYPTION] will be fixed to [WPA2-AES].

## Connecting to the wireless access point ([INFRA(SELECT)]/[INFRA(MANUAL)])

This is the setting to connect the unit to a wireless access point.

### When connecting by searching the wireless access point (SSID)

- 1 Select the [NETWORK] menu → [DEVICE SEL] → [WLAN].
- 2 Select the [NETWORK] menu → [WLAN PROPERTY] → [TYPE] → [INFRA(SELECT)].
- 3 Select the [NETWORK] menu → [WLAN IPv4 SETTING] → [DHCP] → [CLIENT].  
When the wireless access point DHCP function is not to be used, select [OFF].
- 4 Select the [NETWORK] menu → [WLAN PROPERTY] and [WLAN IPv4 SETTING] and set each item as required.
  - For the setting items, refer to “Setting items for [WLAN PROPERTY] and [WLAN IPv4 SETTING] when set to either [INFRA(SELECT)] or [INFRA(MANUAL)]” (→ 176).
- 5 Select the SSID of the searched wireless access point.  
Setting is completed when the [ENCRYPT KEY] (encryption key, password) is not set.
- 6 If the [ENCRYPT KEY] is set, enter the password, and select [Enter].
- 7 Close the menu or return to the level of the [NETWORK] menu.
- 8 Check the network connection.  
Once connected,  is displayed on the screen of the unit.

### When entering the wireless access point (SSID) manually

- 1 Select the [NETWORK] menu → [DEVICE SEL] → [WLAN].
- 2 Select the [NETWORK] menu → [WLAN PROPERTY] → [TYPE] → [INFRA(MANUAL)].
- 3 Select the [NETWORK] menu → [WLAN PROPERTY] and [WLAN IPv4 SETTING] and set each item as required.
  - For the setting items, refer to “Setting items for [WLAN PROPERTY] and [WLAN IPv4 SETTING] when set to either [INFRA(SELECT)] or [INFRA(MANUAL)]” (→ 176).
- 4 In [NETWORK] menu → [WLAN PROPERTY] and [WLAN IPv4 SETTING] → [SSID], enter the SSID of the wireless access point being connected to.  
Setting is completed when the [ENCRYPT KEY] (encryption key, password) is not set.
- 5 If the [ENCRYPT KEY] is set, enter the password, and select [Enter].
- 6 Close the menu or return to the level of the [NETWORK] menu.
- 7 Check the network connection.  
Once connected,  is displayed on the screen of the unit.

### ■ Setting items for [WLAN PROPERTY] and [WLAN IPv4 SETTING] when set to either [INFRA(SELECT)] or [INFRA(MANUAL)]

[WLAN PROPERTY]	[ENCRYPTION]	[WPA-TKIP], [WPA-AES], [WPA2-TKIP], [WPA2-AES], [NONE] (Factory setting: [WPA2-AES])
	[ENCRYPT KEY]	WPA/WPA2 encryption key (Factory setting: [01234567890123456789abcdef])
[WLAN IPv4 SETTING]	[DHCP]	Setting the DHCP function <ul style="list-style-type: none"> <li>• [OFF]: Does not use DHCP.</li> <li>• [CLIENT]: Automatically acquired with the DHCP.</li> </ul> (Factory setting: [OFF])
	[IP ADDRESS]	IP address of the unit (Factory setting: [192.168.0.1])
	[SUBNET MASK]	Subnet mask (Factory setting: [255.255.255.0])
	[DEFAULT GATEWAY]	Default gateway (Factory setting: [192.168.0.254])
	[PRIMARY DNS]	Primary DNS server setting (Factory setting: [0.0.0.0])
	[SECONDARY DNS]	Secondary DNS server setting (Factory setting: [0.0.0.0])

#### NOTE

- Depending on your environment, the communication speed may become slower or the wireless access point may not be available for use.
- The startup time after turning on the power may be longer due to starting of the network.
- When changing the settings of [DEVICE SEL], the changes will not be reflected until the unit is restarted. Also, the setting screen termination may take some time due to the restart of the network service after the setting is changed.
- ENCRYPTION in WEP is not supported.
- Some items cannot be set depending on the settings such as [DHCP].



- When [DHCP] is set to [CLIENT], some of the information acquired automatically with DHCP is displayed in the menu.  
For details of the network status, confirm by selecting the [NETWORK] menu → [INFORMATION] → [STATUS].
- All of the IP address, subnet mask, and default gateway must be correctly set.  
For details, contact the network administrator.
- When the default gateway or DNS is not to be used, set to [0.0.0.0].  
However, DNS cannot be disabled when [DHCP] is set to [CLIENT].
- Depending on the network environment, even if [DHCP] is set to [CLIENT], entry of the DNS value manually may be required. When invalid DNS value is entered in any other cases, the automatic assignment by DHCP will not operate properly.

### Confirming the network status

The network status of the unit can be checked by performing the following operation.

- 1** Select the [NETWORK] menu → [INFORMATION] → [STATUS].

## Connecting to the iPhone/iPad or Android terminal

The unit can be operated from the iPhone/iPad or Android terminal.

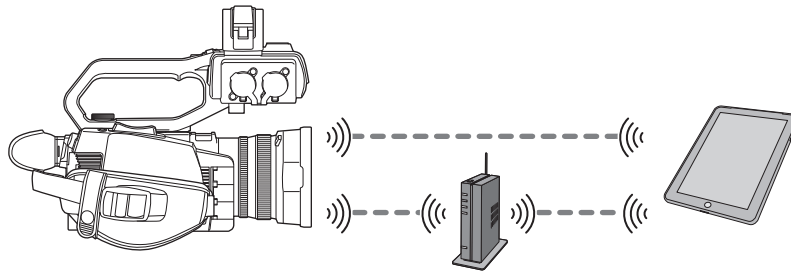

### Unit settings

#### Specifying the network settings

Specify the network settings. (→ 175)

#### Setting the user account name and the password

Set the user account and password for entry into the HC ROP app.

- 1** Select the [NETWORK] menu → [IP REMOTE] → [USER ACCOUNT].
- 2** Enter the user account name and select [Enter].
  - Enter the user account name with 31 characters or less.
- 3** Enter the password and select [Enter].
  - Enter a password between 8 characters and 15 characters.

■ **To enter a character**

Operation is the same as entering with a keyboard.

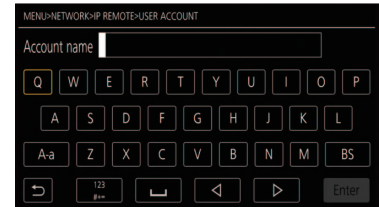

Icon	Description of operation
[A-a]	Switches between upper case and lower case. (Displayed during the text entry mode)
[@-#]	Switches the type of the symbols. (Displayed during the symbol entry mode)
[↶]	Returns to the previous screen. Entered character is not reflected.
123 #+=	Switches the character to symbol/number.
␣	Enters space (blank).
[BS]	Deletes the character. Previous character is deleted when the cursor position is empty.
⬅️/➡️	Moves the cursor to right or left.
[Enter]	Completes the character entry.

#### Enabling the IP remote function

- 1** Select the [NETWORK] menu → [IP REMOTE] → [ENABLE/DISABLE] → [ENABLE].

#### Checking/deleting user accounts

- 1** Select the [NETWORK] menu → [IP REMOTE] → [ACCOUNT LIST].
  - The list of registered user accounts is displayed.
  - Proceed to Step 3 to only check user accounts.
- 2** Select the user account to be deleted.
- 3** When the confirmation message is displayed, select [SET].
- 4** Select [↶] and end the operation.

## Preparing the HC ROP app

Install the HC ROP app to the iPhone/iPad or Android terminal.

### ■ For iPhone/iPad

- Download the HC ROP app from the App Store.

### ■ For Android terminal

- Download the HC ROP app from the Google Play Store.

#### **NOTE**

- For information such as the supported OS of the HC ROP app, refer to the App Store or the Google Play Store download page.

## Connecting to the HC ROP app

Connect to the unit following the HC ROP app guide.

#### **NOTE**

- The unit cannot connect with the HC ROP app while the menu or thumbnail screen is displayed.
- For details about operation of the HC ROP app, refer to the help for the HC ROP app.

## Operation while the HC ROP app is connected

### ■ Operation of the unit that is connected

The <THUMBNAIL> button cannot be used.

### ■ Recording and playback operation while connected

- Recording can be operated by either the unit or the HC ROP app.
- Playback operation is not possible.

#### **NOTE**

- The content set with the remote operation using the HC ROP app is reflected to the unit.

## Streaming function

You can perform streaming of audio and video currently shot with the unit over a network (wireless LAN).

Streaming can be performed using the unit, application software of a device connected via a network, or a server that is capable of receiving streaming video sent from the unit.

There are 2 ways to start streaming: streaming from application software and streaming from the unit. This section describes how to connect the unit to a network for each method.

### Unit settings

#### Specifying the network settings

Specify the network settings. (→ 175)

#### Settings for the streaming function

##### 1 Set the [SYSTEM] menu → [FREQUENCY]/[REC FORMAT].

- For details about the setting items, refer to “Settings when using the streaming function”. (→ 180)

##### 2 Select the [NETWORK] menu → [NETWORK FUNC] → [STREAMING].

Streaming function is enabled.

##### 3 In the [NETWORK] menu → [STREAMING] → [STREAMING FORMAT], set the format when streaming.

- For details about the setting items, refer to “Settings when using the streaming function”. (→ 180)

#### NOTE

- The streaming function can be used when all of the following conditions are satisfied.
  - The [SYSTEM] menu → [SUPER SLOW] → [OFF] is set
  - The menu has been set according to “Settings when using the streaming function” (→ 180) (This cannot be used when set to UHD)
  - Interval recording and background recording are disabled

#### ■ Settings when using the streaming function

[SYSTEM] menu			[NETWORK] menu → [STREAMING]	
[FREQUENCY]	[FILE FORMAT]	[REC FORMAT]	[STREAMING FORMAT]	
[59.94Hz]	[MOV]	[1080-59.94p/422LongGOP 100M]	[1920×1080-60fps 24M]	
		[1080-59.94p/422ALL-I 200M]	[1920×1080-60fps 20M]	
	[MP4]	[1080-59.94p/420LongGOP 50M]	[1920×1080-60fps 16M]	
	[AVCHD]	[1080-59.94p/AVCHD PS]	[1280×720-60fps 14M]	[1280×720-60fps 8M]
			[1280×720-60fps 3M]	[1280×720-60fps 3M]
			[640×360-30fps 4M]	[640×360-30fps 4M]
			[640×360-30fps 1.5M]	[640×360-30fps 1.5M]
			[640×360-30fps 0.7M] (Factory setting)	[640×360-30fps 0.7M] (Factory setting)
			[320×180-30fps 4M]	[320×180-30fps 4M]
	[MOV]	[1080-59.94i/422LongGOP 50M]	[1920×1080-30fps 14M]	[1920×1080-30fps 14M]
			[1920×1080-30fps 6M]	[1920×1080-30fps 6M]
	[MP4]	[1080-29.97p/422LongGOP 50M]	[1920×1080-30fps 1M]	[1920×1080-30fps 1M]
[1280×720-30fps 8M]			[1280×720-30fps 8M]	
[AVCHD]	[1080-59.94i/AVCHD PH]	[1280×720-30fps 2M]	[1280×720-30fps 2M]	
		[1280×720-30fps 1M]	[1280×720-30fps 1M]	
[AVCHD]	[1080-59.94i/AVCHD HA]	[640×360-30fps 4M]	[640×360-30fps 4M]	
		[640×360-30fps 1.5M]	[640×360-30fps 1.5M]	
[MOV]	[1080-23.98p/422LongGOP 50M]	[640×360-30fps 0.7M] (Factory setting)	[640×360-30fps 0.7M] (Factory setting)	
		[320×180-30fps 4M]	[320×180-30fps 4M]	
[MP4]	[1080-23.98p/420LongGOP 50M]	[320×180-30fps 1.5M]	[320×180-30fps 1.5M]	
		[320×180-30fps 0.5M]	[320×180-30fps 0.5M]	
[AVCHD]	[1080-23.98p/AVCHD PH]	[1920×1080-24fps 14M]	[1920×1080-24fps 14M]	
		[1920×1080-24fps 6M]	[1920×1080-24fps 6M]	
[AVCHD]	[720-59.94p/AVCHD PM]	[1920×1080-24fps 1M] (Factory setting)	[1920×1080-24fps 1M] (Factory setting)	
		[1280×720-60fps 14M]	[1280×720-60fps 14M]	
[MP4]	[1080-23.98p/420LongGOP 50M]	[1280×720-60fps 8M]	[1280×720-60fps 8M]	
		[1280×720-60fps 3M]	[1280×720-60fps 3M]	
[AVCHD]	[1080-23.98p/AVCHD PH]	[640×360-30fps 4M]	[640×360-30fps 4M]	
		[640×360-30fps 1.5M]	[640×360-30fps 1.5M]	
[AVCHD]	[720-59.94p/AVCHD PM]	[640×360-30fps 0.7M] (Factory setting)	[640×360-30fps 0.7M] (Factory setting)	
		[320×180-30fps 4M]	[320×180-30fps 4M]	
[MP4]	[1080-23.98p/420LongGOP 50M]	[320×180-30fps 1.5M]	[320×180-30fps 1.5M]	
		[320×180-30fps 0.5M]	[320×180-30fps 0.5M]	

[SYSTEM] menu			[NETWORK] menu → [STREAMING]
[FREQUENCY]	[FILE FORMAT]	[REC FORMAT]	[STREAMING FORMAT]
[50.00Hz]	[MOV]	[1080-50.00p/422LongGOP 100M] [1080-50.00p/422ALL-I 200M]	[1920×1080-50fps 24M] [1920×1080-50fps 20M] [1920×1080-50fps 16M] [1280×720-50fps 14M] [1280×720-50fps 8M] [1280×720-50fps 3M] [640×360-25fps 4M] [640×360-25fps 1.5M] [640×360-25fps 0.7M] (Factory setting) [320×180-25fps 4M] [320×180-25fps 1.5M] [320×180-25fps 0.5M]
	[MP4]	[1080-50.00p/420LongGOP 50M]	
	[AVCHD]	[1080-50.00p/AVCHD PS]	
	[MOV]	[1080-50.00i/422LongGOP 50M] [1080-50.00i/422ALL-I 100M] [1080-25.00p/422LongGOP 50M] [1080-25.00p/422ALL-I 100M]	[1920×1080-25fps 14M] [1920×1080-25fps 6M] [1920×1080-25fps 1M] [1280×720-25fps 8M] [1280×720-25fps 2M] [1280×720-25fps 1M] [640×360-25fps 4M] [640×360-25fps 1.5M] [640×360-25fps 0.7M] (Factory setting) [320×180-25fps 4M] [320×180-25fps 1.5M] [320×180-25fps 0.5M]
	[AVCHD]	[1080-50.00i/AVCHD PH] [1080-50.00i/AVCHD HA]	
	[AVCHD]	[720-50.00p/AVCHD PM]	[1280×720-50fps 14M] [1280×720-50fps 8M] [1280×720-50fps 3M] [640×360-25fps 4M] [640×360-25fps 1.5M] [640×360-25fps 0.7M] (Factory setting) [320×180-25fps 4M] [320×180-25fps 1.5M] [320×180-25fps 0.5M]

### Starting streaming with an operation from the application software

- 1 Select the [NETWORK] menu → [STREAMING] → [START TRIGGER] → [RECEIVER].
- 2 Specify the IP address and the path of the unit with the application software as follows, and start streaming.  
rtsp://(IP address)/stream

#### NOTE

- Perform an operation from the application software to stop streaming.
- Only RTSP is available when starting streaming with an operation from the application software.
- For details about the operations to start streaming from the application software, please see the manual for the application software.
- Streaming stops when performing operations such as displaying the thumbnail screen or playing back clips on the unit.
- Streaming may stop when the date/time is set while streaming.

### Streaming with multicast

One streaming can be distributed to multiple receivers via supported router, etc., when the multicast function is used.

- 1 Select the [NETWORK] menu → [STREAMING] → [START TRIGGER] → [RECEIVER(MULTICAST)].
- 2 Select the [NETWORK] menu → [STREAMING], and specify [MULTICAST ADDRESS] and [MULTICAST PORT].
  - Set [MULTICAST ADDRESS] within following range.
    - IPv4: 224.0.1.0 to 239.255.255.254
  - Set [MULTICAST PORT] within the range of 1024 to 50000.
- 3 Specify the address of the unit and start streaming with the application software.

#### NOTE

- Multicast cannot start streaming with the operation on the unit.

## Starting streaming with an operation on the unit

**1** Select the [NETWORK] menu → [STREAMING] → [START TRIGGER] → [CAMERA].

**2** Set the destination.

For details of setting the destination, refer to “Setting the destination for streaming in the menu of the unit” (→ 182) or “Referring to the memory card for the destination of streaming”. (→ 182)

**3** Select the [NETWORK] menu → [STREAMING] → [START] → [ON].

If the unit is connected to the transmission destination through a network, the unit starts the transmission of streaming video.

### NOTE

- You can also either press the USER button assigned to [STREAMING START] or touch the USER button icon to start/stop streaming from this unit. Streaming cannot be started by pressing the USER button or touching the USER button icon when the menu or the thumbnail screen is displayed.
- In the following cases, it is not possible to select the [START] menu, or use the USER button assigned to [STREAMING START] or the USER button icon.
  - When streaming cannot be started due to reasons such as when connection to the network cannot be established
  - When [NETWORK FUNC] is set to other than [STREAMING]
  - When [START TRIGGER] is set to other than [CAMERA]
- Only RTMP and RTMPS are available when starting streaming with an operation from the unit. In such case, IPv6 cannot be used.
- For settings such as URL, refer to the manual for each streaming service.
- Streaming may not be possible depending on the operating condition of the streaming service.
- Streaming stops when performing operations such as displaying the thumbnail screen or playing back clips on the unit.
- Streaming may stop when the date/time is set while streaming.

## Setting the destination for streaming in the menu of the unit

**1** Select the [NETWORK] menu → [STREAMING] → [CONNECTION INFO.] → [MEMORY].

**2** Enter the destination URL in the [NETWORK] menu → [STREAMING] → [RECEIVER URL].

- Enter the destination URL in following format.
  - rtmp://(server URL):(port number)/(path)/(stream key)
  - rtmps://(server URL):(port number)/(path)/(stream key)

### NOTE

- In general, a parameter for the stream key is required with RTMP, but the stream key may be contained as a part of the path depending on the service. For details, refer to the manual for each streaming service.

## Referring to the memory card for the destination of streaming

**1** Insert the memory card with the destination information saved into card slot 1.

**2** Select the [NETWORK] menu → [STREAMING] → [CONNECTION INFO.] → [SD CARD].

## Management of destination information

Destination information can be saved and loaded between the menu of the unit and the memory card.

### ■ Saving the destination information on the memory card

**1** Insert a memory card formatted with the unit into card slot 1.

**2** Select the [NETWORK] menu → [STREAMING] → [SAVE (SD CARD)].

**3** Select [YES].

### NOTE

- The name of the file in the memory card to save the destination information cannot be changed.
- The file with the destination information saved on the memory card is encrypted.
- Save is not possible when the starting character string of the [RECEIVER URL] (“rtmp://”, etc.) is not set correctly.

### ■ Loading destination information from the memory card

**1** Insert the memory card with the destination information saved into card slot 1.

**2** Select the [NETWORK] menu → [STREAMING] → [LOAD (SD CARD)].

**3** Select [YES].

### NOTE

- The name of the file to load destination information saved on the memory card cannot be selected.
- The setting information that can be loaded (referenced) by the unit is as follows.
  - Information saved with the unit
  - Setting file created with the P2 Network Setting software (→ 183)

## Stopping streaming of video

- 1 Select the [NETWORK] menu → [STREAMING] → [START] → [OFF].

## Entering the setting using the setting tool

### Installing software

Download and expand the P2 Network Setting software for Windows from the following website.  
[https://panasonic.jp/support/global/cs/e\\_cam](https://panasonic.jp/support/global/cs/e_cam)

### Creating the SDXC memory card for setting using the P2 Network Setting software

The SDXC memory card created with this software can be used as the reference destination when loading into the unit's menu or when the [NETWORK] menu → [STREAMING] → [CONNECTION INFO.] → [SD CARD] is selected.

### Setting procedure

- 1 Start the P2 Network Setting software.
- 2 Select the Streaming tab → RTMP tab.
- 3 Enter the destination URL in STREAM DESTINATION URL.
- 4 Click Export and select the destination in the drive selection dialog, and then click OK.
  - This cannot be saved to anything other than a removable drive.

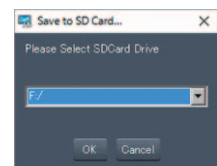
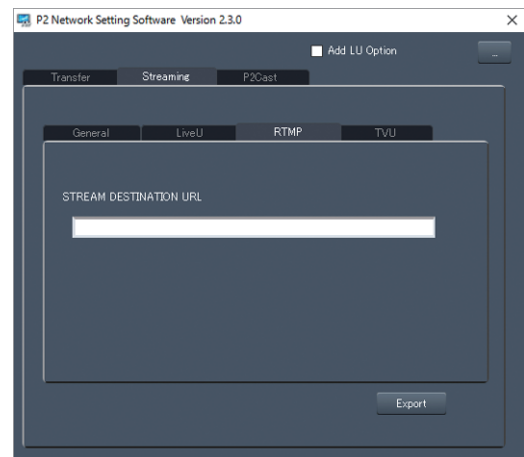

## Chapter 10 **Notes**

---

Maintenance of the unit or frequently asked questions are described.



## Frequently asked questions

### ■ It is not a malfunction in following cases



The lens, the viewfinder or LCD monitor fog up.	This is due to condensation. This is not a malfunction. Please refer to page 13
The unit clatters when tilted forward/backward.	Due to the construction of the unit section, some parts make a clattering sound when the power is turned off. This is not a malfunction.
A short click sound occurs when the power is turned on.	This is an initial operation of the startup of the lens of the camera. This is due to the camera mechanism and is not a malfunction.
Object seems to be warped.	Object seems to be warped slightly when the object moves across the image very fast, but this is because the unit is using MOS for the image sensor. This is not a malfunction.

## Power supply

### ■ What is the power supply voltage supported by the supplied AC adaptor?

- AC 100 V-240 V

### ■ Can the supplied AC adaptor be used while the battery is attached?

- It can be used. The power supply automatically switches to the AC adaptor when you connect an AC adaptor. The power status display in the LCD monitor will change from the  mark to the  mark.

### ■ This unit cannot be turned on. This unit does not stay on long enough. Battery runs down quickly.

- Charge the battery again to ensure it is sufficiently charged. (→ 29)
- In cold places, the battery using time becomes shorter.
- The battery has a limited life. If the operating time is still too short even after the battery is fully charged, the battery has worn out and needs to be replaced.

### ■ This unit cannot be operated though it is turned on.

- Remove the power supply (the battery or the AC adaptor), and connect it again after approximately 1 minute. (Conducting the above operation while the memory card is being accessed may damage the data on the media.)
- If normal operation is still not restored, detach the power connected, and consult the dealer who you purchased this unit from.

### ■ “ERROR OCCURRED. PLEASE TURN UNIT OFF, THEN TURN ON AGAIN.” is displayed.

- The unit has automatically detected an error. Restart the unit by turning off and on.
- The unit will be turned off in about 1 minute if the unit is not turned off and on.
- Repair is needed if it is repeatedly displayed even if it is restarted. Detach the power connected, and consult the dealer who you purchased this unit from. Do not attempt to repair the unit by yourself.

## Battery

### ■ The battery gets exhausted quickly, so is there any way to improve?

- Charge the battery sufficiently.
- The operating time becomes shorter in low temperature.
- If the time is short after sufficient charging, the battery life has expired.

### ■ Can the battery that was used in the previous models used?

- VW-VBD58 (optional) can be used.  
It is recommended to use the following Panasonic genuine batteries.  
– AG-VBR59 (supplied/optional, 7.28 V, 5900 mAh)

### ■ Can the supplied battery be charged with the battery charger AG-B23 (DE-A88) (optional)?

- It can perform normal charging. It cannot perform quick charging.

## Memory card

### ■ If the SD card is inserted in this unit, it is not recognized.

- The memory card to use with the unit should always be formatted on the unit.  
The memory card formatted on a computer cannot be used in the unit.

## Indication

### ■ Function display (Remaining Display, Counter Display, etc.) is not displayed.

- Press the <DISP/MODE CHK> button.
- Check the menu settings in the [VIDEO OUT/LCD/VF] menu → [INDICATOR].
- Press the USER button allocated to [COUNTER] to switch the counter display.

## Shooting

### ■ The focus is not adjusted automatically.

- Is the manual focus mode set? Set the auto focus mode to adjust the focus automatically.
- Are you shooting in conditions which focusing is difficult with the auto focus mode? Auto focus has trouble focusing under certain conditions. In this case, the manual focus mode can be used to focus the unit.

Under following conditions, focus may not be adjusted properly:

- Shooting subjects that is in long and short distances at the same time
- Shooting a subject through a dirty glass
- Shooting in a dark place
- With a glittering object nearby
- Shooting a fast-moving subject
- Shooting a low contrast subject

### ■ The unit arbitrarily stops recording.

- When the recording format is set to MOV format/MP4 format, use SDXC memory cards.  
MOV format/MP4 format data cannot be recorded to SDHC memory cards.
- Use the memory card with the required Speed Class in accordance with the recording bit rate. (→ 39)

### ■ Audio cannot be recorded.

- Audio cannot be recorded in the following cases.
  - When the super slow recording function is enabled\*
  - When the interval recording function is enabled\*
  - When [CH1 LEVEL CONTROL] and [CH2 LEVEL CONTROL] are set to [MUTE] in [MIC SETTING] in the [AUDIO] menu



\*  is displayed in the camera image screen.

### ■ Color or brightness of the image changes, or you may see horizontal bars in the image. The LCD monitor flickers indoors.

- Color or brightness of the image may change, or you may see horizontal bars in the image when the object is recorded under fluorescent light, mercury light or sodium light, etc., but this is not a malfunction.
- Record images in Auto Shutter Mode or adjust the shutter speed to 1/50, 1/60 or 1/100.

## Playback

### ■ The clip cannot be played back.

- The clip displaying  in the thumbnail screen cannot be played back.  
 is displayed on following clips.
  - A clip shot with other device, a clip edited by an editing software
  - Corrupted clip
-  is displayed on the clip in the thumbnail screen for the clips with different system frequency. Change the system frequency.
- The clip with different recording file format (MOV/MP4/AVCHD) is not displayed in the thumbnail screen. Change the recording file format.

### ■ The clip cannot be deleted.

- Cancel the protect on the clip.
- It may not be possible to delete clips that have  displayed on them in the thumbnail screen.  
Format the memory card if the clip is unnecessary.  
All data recorded on the memory card will be deleted when it is formatted. Save the necessary data into a computer, etc.

### ■ Hot swap playback cannot be performed.

- This unit does not support hot swap playback.

## Connections with external devices

### ■ A TV/external monitor is properly connected, but images do not appear. Images are stretched vertically.

- Read the operating instructions for the TV/external monitor, and switch the input to suit the terminal connected.
- Depending on the cable you have used to connect the TV/external monitor, change the settings on this unit. (→ 75, 76)

### ■ Images and audio not being output even when the TV/external monitor is connected to this unit with an HDMI cable.

- Check if the HDMI cable is connected correctly.
- Insert the HDMI cable all the way in.

### ■ If the memory card is inserted in another device, it is not recognized.

- Check that the device is compatible with the capacity or type of memory card (SDHC Memory Card/SDXC Memory Card) that you inserted. Refer to the operating instructions of the device for details.

### ■ When connected by the USB cable, this unit is not detected by the other devices.

- When connected to other devices using the battery, reconnect using the AC adaptor.

## Computers

### ■ When connected by the USB cable, this unit is not detected by the computer.

- After re-inserting the memory card into the unit, reconnect the USB cable.
- Select another USB terminal on the computer.
- Check the operating environment. (→ 171)
- Connect the USB cable again after restarting the computer and turning on this unit again.

### ■ When the USB cable is disconnected, an error message will appear on the computer.

- To disconnect the USB cable safely, double-click the  icon in the task tray and follow the instructions on the screen.

## Others

### ■ Which lens filters can be attached?

- 62 mm (2.44") diameter filters can be attached.

## If AVCHD scenes do not change smoothly when played back on another device

In the following cases, when multiple clips are played back in succession, images may pause for a few seconds when changing between clips.

- The smoothness of playback of successive clips depends on the device used for playback. Depending on the device used for playback, images may pause for a moment even when the following conditions do not apply.
- When clips recorded successively that exceed 4 GB are played back on other devices, the images may pause for a moment every 4 GB.

<p><b>Principal reasons for not playing back smoothly</b></p>	<ul style="list-style-type: none"> <li>• When recordings are made with recording format [PS] and then switched to another recording format for recording</li> <li>• When recordings are made on different dates</li> <li>• When clips less than 3 seconds are recorded</li> <li>• When recordings are made with pre-recording</li> <li>• When recordings are made with interval recording</li> <li>• When clips are deleted</li> <li>• When there are more than 99 recordings in 1 playlist</li> </ul>
---	--

## Warning system

When an error is detected right after the unit is turned on or during the operation, the occurrence of the error is notified in the camera image screen of the LCD monitor or by the tally lamp. Deal with the error by following the indications.



- The tally lamp is available when the handle unit (X2000 supplied, X1500 optional) is attached.

### Cases indicated by error messages

#### System error

Screen display Camera image screen	Description	Behavior and cause
[SYSTEM ERROR]	An error in the standard signal or communication error has occurred.	The tally lamp and all of the card access lamps (orange) flash 4 times each second, and an alarm sounds. <ul style="list-style-type: none"> <li>• Press the power button to turn off the power.</li> </ul>

#### Warning

Screen display Camera image screen	Description	Behavior and cause
[LOW BATTERY]	Remaining battery level is insufficient.	The tally lamp and all of the card access lamps (orange) flash 4 times each second, and an alarm sounds. The power status display becomes  , and it will flash once every second in red. <ul style="list-style-type: none"> <li>• The power is turned off in approximately 5 seconds.</li> <li>• Replace with a fully charged battery, or connect the AC adaptor.</li> </ul>
[HIGH TEMPERATURE]	Displayed when the internal temperature of the main unit has risen above assumed.	The tally lamp and all of the card access lamps (orange) flash 4 times each second, and an alarm sounds. <ul style="list-style-type: none"> <li>• The power is turned off in approximately 5 seconds.</li> <li>• Turn on the power again and check recording and playback operations. If the problem persists, consult the dealer.</li> </ul>
[FAN STOPPED]	The fan has stopped.	<ul style="list-style-type: none"> <li>• The power turns off approximately 1 minute later.</li> <li>• Stop the use immediately when the fan has stopped, and consult the dealer.</li> <li>• If the fan has stopped, temperature of the unit will rise. Therefore, do not use the unit for a long period of time.</li> </ul>
[REC WARNING]	An error of the recording data has occurred during recording, and the recording has stopped.	The tally lamp and all of the card access lamps (orange) flash 4 times each second, and an alarm sounds. <ul style="list-style-type: none"> <li>• Recording is stopped.</li> </ul>
	It has tried to record exceeding the maximum number of clips during recording.	The tally lamp and all of the card access lamps (orange) flash 4 times each second, and an alarm sounds. <ul style="list-style-type: none"> <li>• Recording is stopped.</li> <li>• [REC WARNING] [&lt;OVER MAX NUM. OF CLIPS&gt;] is displayed in the warning display field of the STATUS screen for the mode check.</li> <li>• Replace the memory card or delete unnecessary clips.</li> </ul>
[CARD ERROR <SLOT 1>]/ [CARD ERROR <SLOT 2>]	A data error caused by the memory card has occurred during recording or playback.	<ul style="list-style-type: none"> <li>• When it was recording The tally lamp and all of the card access lamps (orange) flash 4 times each second, and an alarm sounds. Recording is stopped. The memory card where the error has occurred is write protected after recording stops. Replace the memory card in the card slot where the error has occurred.</li> <li>• When it was playing back Playback is stopped.</li> </ul>
[END] (Memory card status display)	The remaining recording capacity of the memory card has exhausted during recording.	The tally lamp and all of the card access lamps (orange) flash 4 times each second, and an alarm sounds. <ul style="list-style-type: none"> <li>• Recording is stopped.</li> <li>• Replace the memory card or delete unnecessary clips.</li> </ul>
 (Once every second, flash in red)	Battery is almost consumed.	Tally lamp flashes once every second. <ul style="list-style-type: none"> <li>• The current operation will continue.</li> <li>• Replace with a fully charged battery, or connect the AC adaptor.</li> </ul>
Remaining recording capacity display of the memory card (Flashes once every second during recording)	The remaining recording capacity of the memory card is getting low.	<ul style="list-style-type: none"> <li>• Recording will continue.</li> <li>• Replace the memory card as necessary.</li> </ul>

## Alert

Screen display	Description	Behavior and cause
Camera image screen		
[SIMUL REC WARNING <SLOT 1>]/ [SIMUL REC WARNING <SLOT 2>]	An error has occurred in one of the memory cards during simultaneous recording.  Recording has been attempted while the number of clips has exceeded the limit on one of the memory cards during simultaneous recording.	<ul style="list-style-type: none"> <li>Recording to the other memory card will continue.</li> <li>Recording to the other memory card will continue.</li> <li>[SIMUL REC WARNING &lt;SLOT 1&gt;] [&lt;OVER MAX NUM. OF CLIPS&gt;]/[SIMUL REC WARNING &lt;SLOT 2&gt;] [&lt;OVER MAX NUM. OF CLIPS&gt;] is displayed in the warning display field of the STATUS screen for the mode check.</li> <li>Replace the memory card or delete unnecessary clips.</li> </ul>
[BACKGROUND REC WARNING <SLOT 1>]/[BACKGROUND REC WARNING <SLOT 2>]	An error has occurred in one of the memory cards during background recording.  Recording has been attempted while the number of clips has exceeded the limit on one of the memory cards during background recording.	<ul style="list-style-type: none"> <li>Recording to the other memory card will continue.</li> <li>[BACKGROUND REC WARNING &lt;SLOT 1&gt;] [&lt;OVER MAX NUM. OF CLIPS&gt;]/[BACKGROUND REC WARNING &lt;SLOT 2&gt;] [&lt;OVER MAX NUM. OF CLIPS&gt;] is displayed in the warning display field of the STATUS screen for the mode check.</li> <li>Replace the memory card or delete unnecessary clips.</li> </ul>
[REINSERT OR CHECK CARD <SLOT 1>]/[REINSERT OR CHECK CARD <SLOT 2>]	The memory card cannot be recognized properly because a recording medium which is not supported has been inserted or there is dirt on the terminal of the memory card.	<ul style="list-style-type: none"> <li>Check the memory card that is inserted.</li> <li>Insert the memory card again if displayed when inserting a memory card.</li> </ul>
[FORMAT ERROR CARD <SLOT 1>]/[FORMAT ERROR CARD <SLOT 2>]	A memory card with management information out of specifications has been inserted. (Include when the system frequency (59.94 Hz system or 50.00 Hz system) for the AVCHD format of the memory card is different from the setting in the [SYSTEM] menu → [FREQUENCY])	<ul style="list-style-type: none"> <li>Insert a memory card that can record.</li> <li>The system frequency information for the AVCHD format is confirmed at the time of formatting or at the first recording.</li> </ul>
[NOT SDXC CARD <SLOT 1>]/[NOT SDXC CARD <SLOT 2>]	When [FILE FORMAT] is set to MOV format/MP4 format, there is a memory card inserted to which MOV format/MP4 format data cannot be recorded.	<ul style="list-style-type: none"> <li>Insert a SDXC memory card.</li> </ul>
[INCOMPATIBLE CARD <SLOT 1>]/[INCOMPATIBLE CARD <SLOT 2>]	A memory card that may not be able to record due to slow writing speed has been inserted.	<ul style="list-style-type: none"> <li>The current operation will continue.</li> <li>Use a memory card with sufficient writing speed.</li> </ul>
[BACKUP BATT EMPTY]	A drop in the voltage of the backup battery for the internal clock was detected when the power button was pressed to turn the power on.	<ul style="list-style-type: none"> <li>The current operation will continue.</li> <li>Set the date/time again after charging the built-in battery.</li> </ul>

## Message

Screen display	Description	Behavior and cause
Camera image screen		
[CANNOT PLAY.]	This is a clip that cannot be played back. (When it cannot be played back due to difference of the system frequency, etc.) An error has occurred during playback, and the playback has stopped.	<ul style="list-style-type: none"> <li>Confirm if the system frequency of the clip is the same as the system frequency of the unit.</li> <li>Check the clip.</li> </ul>
[CANNOT DELETE.]	This is a clip that cannot be deleted.	<ul style="list-style-type: none"> <li>Match the device and content versions.</li> </ul>
[CANNOT RECORD. THE NUMBER OF CLIPS HAS EXCEEDED THE MAXIMUM LIMIT.]	The number of clips that can be recorded has reached the maximum.	<ul style="list-style-type: none"> <li>Replace the memory card or delete unnecessary clips.</li> </ul>
[CARD ERROR. PLEASE REFORMAT.]	Formatting of the memory card has failed.	<ul style="list-style-type: none"> <li>Format it again.</li> </ul>
[CANNOT COPY TO SAME CARD.]	The clip recorded over multiple memory cards cannot be copied to a same card.	<ul style="list-style-type: none"> <li>Copy to a card not containing a clip that is recorded over multiple memory cards.</li> </ul>
[Repair failed.]	Repairing the clip where an error occurred has failed because the power was disconnected or the memory card was removed during recording. Restoring of the management information has failed.	<ul style="list-style-type: none"> <li>Check the memory card.</li> </ul>
[UNABLE TO FORMAT.]	This memory card cannot be formatted.	<ul style="list-style-type: none"> <li>Check the memory card.</li> </ul>
[CANNOT PROTECT.]	This is a clip that cannot be protected.	<ul style="list-style-type: none"> <li>Match the device and content versions.</li> </ul>
[THE CLIP IS PROTECTED. PLEASE CANCEL PROTECTION.]	The clip is protected so it cannot be deleted.	<ul style="list-style-type: none"> <li>Cancel the protect on the clip.</li> </ul>
[THUMBNAIL DATA ERROR IS DETECTED.]	An error occurred in the thumbnail information of the memory card.	<ul style="list-style-type: none"> <li>Restoring of the management information is performed automatically after this.</li> </ul>
[CANNOT RECORD - INCOMPATIBLE CONTROL DATA.]	The version of the management information on the memory card is not supported.	<ul style="list-style-type: none"> <li>Match the device and content versions.</li> </ul>
[CANNOT SET.]	This cannot be set.	<ul style="list-style-type: none"> <li>Perform the setting after making it possible to set.</li> </ul>
[THIS CLIP CANNOT BE COPIED.]	The clip cannot be copied.	<ul style="list-style-type: none"> <li>Copy the clips other than the corresponding clip.</li> </ul>
[CONTROL DATA ERROR HAS BEEN DETECTED. (SD CARD)]	An error occurred in the management information of the memory card.	<ul style="list-style-type: none"> <li>Restoring of the management information is performed automatically after this.</li> </ul>
[COPY FAILED. PLEASE CHECK THE CARD.]	The clip has failed to copy due to an error in the memory card.	<ul style="list-style-type: none"> <li>Check the memory card.</li> </ul>
[CANNOT COPY - THE NUMBER OF CLIPS HAS REACHED MAXIMUM.]	The number of clips that can be copied has reached the maximum.	<ul style="list-style-type: none"> <li>Replace the memory card in the copy destination or delete unnecessary clips.</li> </ul>
[LOW BATTERY. PLEASE CONNECT AC ADAPTOR OR CHANGE BATTERY.]	It is trying to copy a clip or update the firmware of the unit when the remaining battery level is insufficient.	<ul style="list-style-type: none"> <li>Replace with a fully charged battery, or connect the AC adaptor.</li> </ul>
[CANNOT PLAY THIS CLIP ON THIS MODEL.]	This is a clip that cannot be played back with the unit.	<ul style="list-style-type: none"> <li>Playback on a device that can playback.</li> </ul>
[Cannot copy: contains recordings from other devices.]	The clip recorded in other device cannot be copied.	<ul style="list-style-type: none"> <li>Copy the clips other than the corresponding clip.</li> </ul>
[INVALID]	Operation is disabled.	<ul style="list-style-type: none"> <li>Operate after the operation becomes enabled.</li> </ul>
[Cannot record - Playlist capacity is full.]	The unit tried to record on a memory card where the number of playlists for recording has reached the maximum.	<ul style="list-style-type: none"> <li>Replace the memory card or delete unnecessary clips.</li> </ul>
[Cannot copy - Playlist capacity is full.]	The unit tried to copy to a memory card where the number of playlists for recording has reached the maximum.	<ul style="list-style-type: none"> <li>Replace the memory card or delete unnecessary clips.</li> </ul>
[Exceeds capacity. Please reselect.]	The remaining recording capacity of the memory card for the copy destination is insufficient.	<ul style="list-style-type: none"> <li>Select the clip to copy again, or secure enough space in the remaining recording capacity on the memory card for the copy destination.</li> </ul>
[Check the destination media.]	An error has occurred on the memory card for the copy destination while copying.	<ul style="list-style-type: none"> <li>Confirm the memory card for the copy destination.</li> </ul>
[LOAD NG]	Loading of the scene file has failed.	<ul style="list-style-type: none"> <li>Check the memory card.</li> </ul>
[SAVE NG]	Writing of the scene file has failed.	<ul style="list-style-type: none"> <li>Check the memory card.</li> </ul>
[DISCONNECT USB CABLE.]	Due to an OS non-compatible error, 5 minutes has elapsed until the service mode connection is established.	<ul style="list-style-type: none"> <li>Confirm if the OS in use is supported by the unit.</li> </ul>
[CARD LOCKED.]	The unit tried to protect or delete a clip on a memory card that has been locked. The unit tried to copy a clip to the memory card that has been locked.	<ul style="list-style-type: none"> <li>Unlock the memory card.</li> </ul>
[CANNOT SELECT MORE CLIPS.]	It has tried to select more than 99 clips.	<ul style="list-style-type: none"> <li>Execute the process such as copying by every 99 clips.</li> </ul>
[SELECT THE CLIP TO BE DELETED.]	It has tried to delete a clip without choosing any.	<ul style="list-style-type: none"> <li>Select a clip to be deleted.</li> </ul>
[SELECT THE CLIPS TO COPY.]	It has tried to copy a clip without choosing any.	<ul style="list-style-type: none"> <li>Select a clip to be copied.</li> </ul>

Chapter 10 Notes — Warning system

Screen display	Description	Behavior and cause
Camera image screen		
[Insert a card in slot 1.]	Copying was tried to be executed without inserting a memory card into card slot 1.	<ul style="list-style-type: none"> <li>● Insert a memory card into card slot 1.</li> </ul>
[Insert a card in slot 2.]	Copying was tried to be executed without inserting a memory card into card slot 2.	<ul style="list-style-type: none"> <li>● Insert a memory card into card slot 2.</li> </ul>
[REINSERT OR CHECK CARD <SLOT 1>]/[REINSERT OR CHECK CARD <SLOT 2>]	It has tried to copy to an error card.	<ul style="list-style-type: none"> <li>● Check the memory card.</li> </ul>
[CANNOT COPY.]	Copying was attempted while the system frequency (59.94 Hz and 50.00 Hz) of the memory card to copy from and the memory card to copy to are different for content recorded in AVCHD format.	<ul style="list-style-type: none"> <li>● Set the same system frequency (59.94 Hz system or 50.00 Hz system) for the content of the memory card to copy from and the memory card to copy to.</li> <li>● The system frequency information for the AVCHD format is confirmed at the time of formatting or at the first recording.</li> </ul>
[CANNOT RECORD.]	Cannot be recorded.	<ul style="list-style-type: none"> <li>● Perform recording after making it possible.</li> </ul>
[REC PAUSE INVALID]	The unit tried to stop the next recording before the previous recording finished writing to the memory card.	<ul style="list-style-type: none"> <li>● Stop recording after writing to the memory card is complete. Recording can be stopped after the message that is displayed disappears.</li> </ul>
[WRITE PROTECTED]	The memory card has been write-protected.	<ul style="list-style-type: none"> <li>● Insert a memory card with write access.</li> </ul>

## Recording function that cannot be used simultaneously

Depending on the recording function that is set, there are recording functions that cannot be used simultaneously.

- Meaning of the symbols used in the table are as follows.
  - ✓: Can be used simultaneously.
  - —: Cannot be used simultaneously.

Recording function to additionally set	Recording function that is set					
	Pre-recording	Relay recording	Simultaneous recording	Interval recording	Background recording	Super slow recording
Pre-recording		✓	✓	—	—	—
Relay recording	✓		—	—	—	—
Simultaneous recording	✓	—		✓	—	—
Interval recording	—	—	✓		—	—
Background recording	—	—	—	—		—
Super slow recording	—	—	—	—	—	



## Updating the unit's firmware

---

Confirm the firmware version of the unit in the [OTHERS] menu → [INFORMATION] → [VERSION], access the most current information regarding firmware in the website described in NOTE, and download the firmware as necessary.

### NOTE

---

- Update is completed by loading the downloaded file to the unit via the memory card. Insert the memory card that stores the update file into card slot 1, and select the [OTHERS] menu → [INFORMATION] → [UPDATE].

For the latest update information, check the support website below. (As of January 2020)

[https://panasonic.jp/support/global/cs/e\\_cam](https://panasonic.jp/support/global/cs/e_cam)

(This website is in English only.)

- When updating the firmware, use the AC adaptor or sufficiently charged battery.
- Do not turn off the power while updating the firmware. Rewriting of the firmware may fail and the unit may not be activated.

## Cleaning and storing

### Cleaning the main unit

- Remove the battery or disconnect the AC cable from the power outlet before cleaning.
- Do not use benzine or thinner to clean the unit. Using benzine or thinner may cause deformation or peeling off of the paint of the main unit.
- Wipe the main unit with a soft and clean cloth. For heavy dirt, wipe with a cloth soaked in kitchen detergent diluted with water, and then with a dry cloth.
- When using a chemical dust cloth, follow the instructions that came with the cloth.

### Cautions for storage

Remove the battery from the main unit when storing. Store them in a place where humidity is low and temperature is relatively constant.

When storing the unit, it is recommended that you place a desiccant (silica gel) in with it.

- Recommended temperature: 15 °C to 25 °C (59 °F to 77 °F)
- Recommended relative humidity: 40% to 60%

#### ■ Main unit

- Wrap in a soft cloth to prevent dust from getting inside.

#### ■ Battery

- The battery life shortens where the temperature is extremely high or low.
- Storing in a place where there is heavy oil smoke or dust may lead to malfunctions due to rust on terminal connectors, etc.
- Do not let the battery terminal contact a metal object (such as a necklace or hairpin). Short circuit may occur between terminals and it may lead to heat generation. Touching on a heated part may cause severe burns.
- Store the battery with electrically discharged. For long-term storage, it is recommended to charge the battery at least once a year and use it up completely on the unit before storing it again.
- Remove dust and other debris that gather on the contacts of the battery.

#### ■ Memory card

- Do not allow dirt, water, or other foreign objects to get into the contacts on the back of the card.
- If you remove it from the unit, be sure to put it in its case.
- Do not place SD cards in the following areas:
  - Where corrosive gases, etc., may be generated
  - In places exposed to direct sunlight, or places with high temperatures such as near heating devices
  - Where there is excessive moisture or dust
  - Locations susceptible to significant difference in temperature (condensation can occur.)
  - Where static electricity or electromagnetic waves occur

## Chapter 11 **Specification**

---

This chapter describes the specifications of this product.

## Dimensions

### Main unit

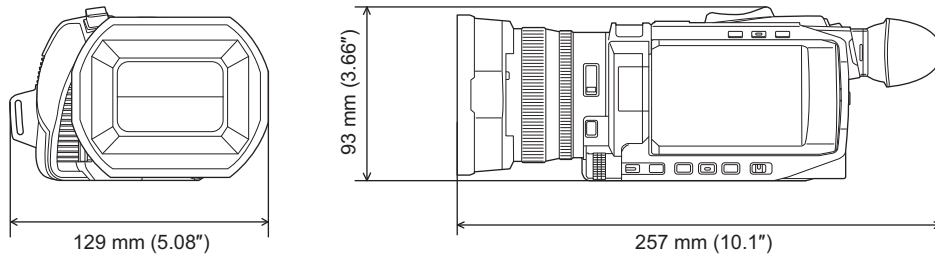

### When the handle unit is attached ( X2000 supplied, X1500 optional)

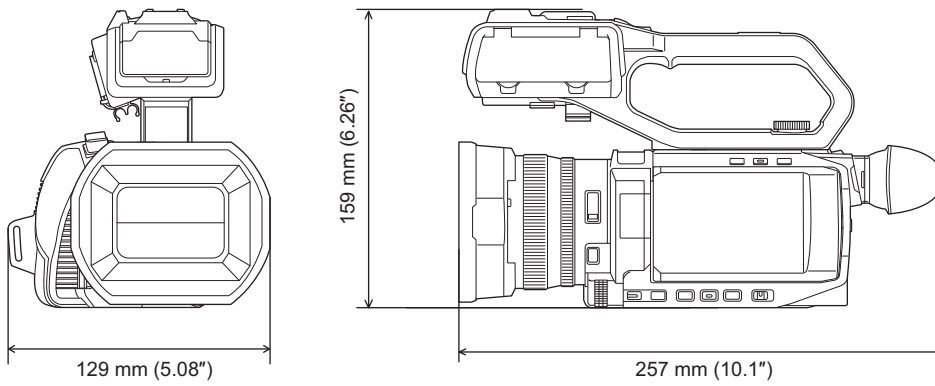

# Specifications

## General

<b>Power</b> 7.28 V $\equiv$ (when battery is used) 12 V $\equiv$ (when the AC adaptor is used)
<b>Power consumption</b> 22.9 W (Charging) X1500 14.4 W (When the LCD monitor is used) X2000 15.5 W (When the LCD monitor is used)

Item	X1500	X2000
Ambient operating temperature	0 °C to 40 °C (32 °F to 104 °F)	
Ambient operating humidity	10% to 80% (relative humidity, no condensation)	
Mass (Weight)	Approx. 0.9 kg (Approx. 1.98 lbs.) (main unit only, excluding lens hood, battery, and supplied accessories)	Approx. 0.9 kg (Approx. 1.98 lbs.) (main unit only, excluding handle unit, lens hood, battery, and supplied accessories)
	Approx. 1.2 kg (Approx. 2.65 lbs.) (including lens hood, battery and eye cup)	Approx. 1.5 kg (Approx. 3.31 lbs.) (including handle unit, lens hood, battery and eye cup)
External dimensions (W×H×D)	129 mm×93 mm×257 mm (5.08"×3.66"×10.1") (including lens hood and eye cup, excluding protrusions)	129 mm×159 mm×257 mm (5.08"×6.26"×10.1") (including handle unit, lens hood, and eye cup, excluding protrusions)

## Camera

Pickup device	1/2.5" MOS solid-state image sensing device for colors Total pixels: approx. 8,570,000 pixels
Number of pixels	Number of effective pixels: approx. 8,290,000 pixels
Lens	Optical image stabilizer lens, motorized 24× zoom F1.8 to F4.0 (f=4.12 mm to 98.9 mm) 35 mm conversion: f=25.0 mm to 600.0 mm
Filter diameter	62 mm (2.44")
ND filter	<CLR>, <1/4>, <1/16>, <1/64>
Minimum object distance (M.O.D)	Approx. 0.1 m (3.93") (wide angle) from the lens Approx. 1.2 m (47.2") (telephoto angle) from the lens
IR cut filter	Has functionality to switch IR filter on/off (switched with [IR REC] USER button or menu)
Gain setting	0 dB to 30 dB ● When [S.GAIN] is assigned to a USER button, [SUPER GAIN]/[SUPER GAIN+] can be set
Color temperature setting	ATW, ATW LOCK, Ach, Bch, preset 3200 K/preset 5600 K/VAR (2000 K to 15000 K)
Shutter speed	When the [SYSTEM] menu → [FREQUENCY] → [59.94Hz] is set ● 59.94i/59.94p mode: 1/60 sec., 1/100 sec., 1/120 sec., 1/180 sec., 1/250 sec., 1/350 sec., 1/500 sec., 1/750 sec., 1/1000 sec., 1/1500 sec., 1/2000 sec., 1/3000 sec., 1/4000 sec., 1/8000 sec. ● 29.97p mode: 1/30 sec., 1/50 sec., 1/60 sec., 1/100 sec., 1/120 sec., 1/180 sec., 1/250 sec., 1/350 sec., 1/500 sec., 1/750 sec., 1/1000 sec., 1/1500 sec., 1/2000 sec., 1/3000 sec., 1/4000 sec., 1/8000 sec. ● 23.98p mode: 1/24 sec., 1/48 sec., 1/50 sec., 1/60 sec., 1/100 sec., 1/120 sec., 1/180 sec., 1/250 sec., 1/350 sec., 1/500 sec., 1/750 sec., 1/1000 sec., 1/1500 sec., 1/2000 sec., 1/3000 sec., 1/4000 sec., 1/8000 sec. When the [SYSTEM] menu → [FREQUENCY] → [50.00Hz] is set ● 50.00i/50.00p mode: 1/50 sec., 1/60 sec., 1/100 sec., 1/125 sec., 1/180 sec., 1/250 sec., 1/350 sec., 1/500 sec., 1/750 sec., 1/1000 sec., 1/1500 sec., 1/2000 sec., 1/3000 sec., 1/4000 sec., 1/8000 sec. ● 25.00p mode: 1/25 sec., 1/50 sec., 1/60 sec., 1/100 sec., 1/125 sec., 1/180 sec., 1/250 sec., 1/350 sec., 1/500 sec., 1/750 sec., 1/1000 sec., 1/1500 sec., 1/2000 sec., 1/3000 sec., 1/4000 sec., 1/8000 sec.
Slow shutter speed	When the [SYSTEM] menu → [FREQUENCY] → [59.94Hz] is set ● 59.94i/59.94p mode: 1/8 sec., 1/15 sec., 1/30 sec. ● 29.97p mode: 1/8 sec., 1/15 sec. ● 23.98p mode: 1/6 sec., 1/12 sec. When the [SYSTEM] menu → [FREQUENCY] → [50.00Hz] is set ● 50.00i/50.00p mode: 1/6 sec., 1/12 sec., 1/25 sec. ● 25.00p mode: 1/6 sec., 1/12 sec.

## Chapter 11 Specification — Specifications

Super slow recording	<ul style="list-style-type: none"> <li>● [SYSTEM] menu → [FREQUENCY] → [59.94Hz] When the number of recording pixels is 1920×1080 (FHD) Recording frame rate 120 fps, slow motion effect 1/2 speed (in 59.94p mode), slow motion effect 1/4 speed (in 29.97p mode), 1/5 speed (in 23.98p mode)</li> <li>● [SYSTEM] menu → [FREQUENCY] → [50.00Hz] When the number of recording pixels is 1920×1080 (FHD) Recording frame rate 100 fps, slow motion effect 1/2 speed (in 50.00p mode), slow motion effect 1/4 speed (in 25.00p mode)</li> </ul>
Minimum illuminance of subject	1.5 lx (F1.8, [SUPER GAIN+] is enabled, when shutter speed is 1/30 sec.)
Digital zoom	2×/5×/10×/i.ZOOM (maximum 48×)
Built-in LED light (When using the handle unit (X2000) supplied, (X1500) optional))	Illuminance: approx. 70 lx (1.0 m (approx. 3.3 feet)) Illumination angle: approx. 30° Color temperature: approx. 4600 K
Lens hood	Hood with lens cover

### Memory card recorder

Recording media	SDHC memory card (4 GB to 32 GB), SDXC memory card (exceeding 32 GB to 128 GB): UHS-I, UHS Speed Class 3 compatible ● Refer to "Speed Class during shooting" (→ 39).
Recording slot	2 slots
System frequency	59.94 Hz/50.00 Hz
File format	MOV (HEVC), MOV, MP4 (HEVC), MP4, AVCHD
Recording format	<ul style="list-style-type: none"> <li>● MOV: 4:2:0 (10bit) UHD (3840×2160); HEVC LongGOP 200M (Average approx. 200 Mbps)/ HEVC LongGOP 150M (Average approx. 150 Mbps)/ HEVC LongGOP 100M (Average approx. 100 Mbps)</li> <li>● MOV: 4:2:0 (8bit) UHD (3840×2160); 420LongGOP 150M (Average approx. 150 Mbps)/ 420LongGOP 100M (Average approx. 100 Mbps)</li> <li>● MOV: 4:2:2 (10bit) UHD (3840×2160); 422LongGOP 150M (Average approx. 150 Mbps) FHD (1920×1080); 422LongGOP 100M (Average approx. 100 Mbps)/ 422LongGOP 50M (Average approx. 50 Mbps)/ 422ALL-I 200M (Average approx. 200 Mbps)/ 422ALL-I 100M (Average approx. 100 Mbps)</li> <li>● MP4: 4:2:0 (10bit) UHD (3840×2160); HEVC LongGOP 100M (Average approx. 100 Mbps)/ HEVC LongGOP 72M (Average approx. 72 Mbps)</li> <li>● MP4: 4:2:0 (8bit) UHD (3840×2160); 420LongGOP 72M (Average approx. 72 Mbps) FHD (1920×1080); 420LongGOP 50M (Average approx. 50 Mbps)</li> <li>● AVCHD: 4:2:0 (8bit) FHD (1920×1080); PS (Average approx. 25 Mbps)/PH (Average approx. 21 Mbps)/ HA (Average approx. 17 Mbps) HD (1280×720); PM (Average approx. 8 Mbps)</li> </ul>
Number of recording pixels/Recording video signal	3840×2160/59.94p, 50.00p, 29.97p, 25.00p, 23.98p 1920×1080/59.94p, 50.00p, 29.97p, 25.00p, 23.98p, 59.94i, 50.00i 1280×720/59.94p, 50.00p
Recording and playback time	When using 64 GB SDXC memory card, with [FILE FORMAT] set to [MOV] or [MP4]: <ul style="list-style-type: none"> <li>● With a 200 Mbps recording format: approx. 40 minutes</li> <li>● With a 150 Mbps recording format: approx. 55 minutes</li> <li>● With a 100 Mbps recording format: approx. 1 hour 20 minutes</li> <li>● With a 72 Mbps recording format: approx. 1 hour 50 minutes</li> <li>● With a 50 Mbps recording format: approx. 2 hours 40 minutes</li> </ul> When using 64 GB SDXC memory card, with [FILE FORMAT] set to [AVCHD]: <ul style="list-style-type: none"> <li>● With a PS recording format: approx. 5 hours 20 minutes</li> <li>● With a PH recording format: approx. 6 hours</li> <li>● With a HA recording format: approx. 8 hours 30 minutes</li> <li>● With a PM recording format: approx. 17 hours 10 minutes</li> </ul>
2-slot function	Relay recording, simultaneous recording, background recording
Still image recording	Recording format: JPEG (DCF/Exif2.2) ● Refer to page 155 for recording formats and the number of recording pixels.

## Digital video

Number of quantizing bits	<ul style="list-style-type: none"> <li>● MOV: 4:2:2 (10bit)/4:2:0 (8bit)/4:2:0 (10bit (HEVC))</li> <li>● MP4: 4:2:0 (8bit)/4:2:0 (10bit (HEVC))</li> <li>● AVCHD: 4:2:0 (8bit)</li> </ul>
Video compression format	<ul style="list-style-type: none"> <li>● MOV/MP4: H.264/MPEG-4 AVC High Profile, H.265/MPEG-H HEVC Main10 Profile</li> <li>● AVCHD: H.264/MPEG-4 AVC High Profile</li> </ul>

## Digital audio

Recording audio signal	<ul style="list-style-type: none"> <li>● MOV: 48 kHz/24bit, 2ch</li> <li>● MP4/AVCHD: 48 kHz/16bit, 2ch</li> </ul>
Audio compression format	<ul style="list-style-type: none"> <li>● MOV: LPCM</li> <li>● MP4: AAC</li> <li>● AVCHD: Dolby Audio™</li> </ul>
Headroom	12 dB

## Streaming

Video compression format	H.264/MPEG-4 AVC Main Profile H.264/MPEG-4 AVC High Profile
Video resolution	1920×1080 (FHD), 1280×720 (HD), 640×360, 320×180
Streaming method	Unicast, Multicast
Frame rate	<ul style="list-style-type: none"> <li>● When set to the [SYSTEM] menu → [FREQUENCY] → [59.94Hz]: 30 fps, 60 fps</li> <li>● When set to the [SYSTEM] menu → [FREQUENCY] → [50.00Hz]: 25 fps, 50 fps</li> </ul>
Bit rate	24 Mbps, 20 Mbps, 16 Mbps, 14 Mbps, 8 Mbps, 6 Mbps, 4 Mbps, 3 Mbps, 2 Mbps, 1.5 Mbps, 1 Mbps, 0.7 Mbps, 0.5 Mbps
Audio compression format	AAC-LC: 48 kHz/16-bit, 2ch
Supported protocol	RTSP/RTP/RTMP/RTMPS

## Wi-Fi

Compliance standard	IEEE802.11b/g/n compliant
Frequency range used (central frequency)	2412 MHz to 2462 MHz [1 to 11ch]
Encryption method	Wi-Fi compliant WPA™/WPA2™
Access method	Infrastructure mode

## Video output

Item	X1500	X2000
<SDI OUT> terminal	—	<ul style="list-style-type: none"> <li>● BNC terminal ×1 0.8 V [p-p], 75 Ω, 3G/1.5G HD-SDI compatible</li> <li>● Output format 1920×1080: 59.94p LEVEL-A, 50.00p LEVEL-A, 59.94i, 50.00i, 29.97PsF, 25.00PsF, 23.98PsF 1280×720: 59.94p, 50.00p</li> </ul>
<HDMI> terminal	<ul style="list-style-type: none"> <li>● HDMI type A terminal ×1 (not compatible with VIERA Link)</li> <li>● Output format 3840×2160: 59.94p, 50.00p, 29.97p, 25.00p, 23.98p 1920×1080: 59.94p, 50.00p, 59.94i, 50.00i, 29.97p, 25.00p, 23.98p 1280×720: 59.94p, 50.00p 720×480: 59.94p 720×576: 50.00p</li> </ul>	

## Audio input

Built-in microphone	Supports stereo microphone
<MIC> terminal	3.5 mm (0.14") diameter stereo mini jack × 1
<INPUT 1>/<INPUT 2> terminal (When using the handle unit ([X2000] supplied, [X1500] optional))	XLR×2, 3-pin Input high impedance, <LINE>/<MIC>/<+48V> (Switched with <INPUT 1>/<INPUT 2> switch) <ul style="list-style-type: none"> <li>• &lt;LINE&gt;: 4 dBu/0 dBu (switched with menu)</li> <li>• &lt;MIC&gt;: -40 dBu/-50 dBu/-60 dBu (switched with menu)</li> </ul>

## Audio output

Item	[X1500]	[X2000]
<SDI OUT> terminal	—	LPCM 2ch <ul style="list-style-type: none"> <li>• Gain switching: 0 dB/-6 dB/-8 dB (switched with menu)</li> </ul>
<HDMI> terminal	LPCM 2ch	
Headphone terminal	3.5 mm (0.14") diameter stereo mini jack × 1	
Speaker	15 mm (approx. 0.59") diameter, round × 1	

## Other input/output

<REMOTE> terminal	2.5 mm (approx. 0.10") diameter super mini jack × 1
USB terminal (USB2.0)	Micro-AB terminal, 5pin, with USB mass storage functionality (read only)
<DC IN 12V> terminal	DC12 V, EIAJ type 4

## Monitor

LCD monitor	3.5" LCD monitor (approx. 2,760,000 dots)
Viewfinder	0.24" EVF (equivalent to approx. 1,560,000 dots)

## Handle unit ([X2000] supplied, [X1500] optional)

<b>Power consumption</b> Maximum approx. 3.1 W (when connected to the camera)	
Mass (Weight)	Approx. 305 g (Approx. 0.67 lbs.) (main part of the handle unit only, excluding microphone holder and microphone holder mounting screws)
External dimensions (W×H×D)	Approx. 71 mm×89 mm×207 mm (Approx. 2.80"×3.50"×8.15") (including protrusions, excluding microphone holder)

## AC adaptor

<b>Power source</b> 100 V – 240 V ~ 50 Hz/60 Hz, 1.2 A 79 VA (100 V ~) – 99 VA (240 V ~)	
<b>Power output</b> 12 V --- 3.0 A	
Ambient operating temperature	0 °C to 40 °C (32 °F to 104 °F)
Ambient operating humidity	10% to 90% (relative humidity, no condensation)
Mass (Weight)	Approx. 225 g (Approx. 0.496 lbs.)
External dimensions (W×H×D)	115 mm×37 mm×57 mm (4-1/2"×1-7/16"×2-1/4") (excluding the DC cable section)

## Battery pack (AG-VBR59)

<b>Voltage/capacity</b> 7.28 V --- 5900 mAh 43 Wh	
Charging current	Maximum 4000 mA
Ambient operating humidity	0% to 80% (relative humidity, no condensation)
Mass (Weight)	Approx. 230 g (Approx. 0.507 lbs.)
External dimensions (W×H×D)	41.3 mm×51.3 mm×69.6 mm (1-5/8"×2"×2-3/4")



# Index

- A**
- AC adaptor ..... 29
  - AE level (exposure compensation) ..... 110
  - Area mode function ..... 112
  - ATW ..... 116
  - Audio input ..... 125
    - Audio device ..... 126
    - Built-in microphone ..... 125
    - Confirming setting ..... 128
    - External microphone ..... 126
    - Level adjustment ..... 126
    - Monitor ..... 128
    - Switching ..... 125
  - Auto tracking white balance ..... 116
- B**
- Background recording ..... 131
  - Battery
    - Charging ..... 29
    - Mounting ..... 28
    - Removing ..... 28
  - Black balance ..... 117
  - Black control function ..... 122
  - Brightness adjustment ..... 111
  - Built-in battery ..... 37
  - Built-in LED light ..... 120
- C**
- Camera image screen ..... 59, 159
  - Card reader mode ..... 170
  - Center marker ..... 134
  - Chroma setting function ..... 121
  - Clip
    - Copying ..... 149
    - Deleting ..... 150
    - Playback ..... 152
    - Protecting ..... 150
    - Restoring ..... 151
  - Clock ..... 38
  - Color correction function ..... 122
- D**
- Date and time ..... 38
  - Detail function ..... 121
  - Digital zoom function ..... 141
  - Dynamic range stretcher function ..... 139
- E**
- Error message ..... 188
  - External microphone
    - Mounting ..... 35
  - Eye cup ..... 32
- F**
- Face detection/tracking AE&AF function ..... 138
  - Focus assist function ..... 135
  - Frame marker ..... 135
- G**
- Gain ..... 109
  - Gamma function ..... 122
- H**
- Handle unit
    - Attachment ..... 33
  - HC ROP app ..... 179
  - Headphones ..... 168
  - High-speed shooting ..... 124
- I**
- Interval recording ..... 132
  - IR recording ..... 133
  - Iris ..... 108
- K**
- Knee function ..... 122
- L**
- LCD monitor ..... 53
    - Status display ..... 159
  - Lens cover ..... 32
  - Lens hood ..... 31
  - Level gauge ..... 141
- M**
- Manual focus ..... 111
  - Matrix function ..... 121
  - Memory card ..... 39
    - Folder structure ..... 44
    - Format ..... 41
    - Insert ..... 41
    - Recording time ..... 42
    - Remove ..... 41
    - Status ..... 40
    - Write-protected ..... 40
  - Menu
    - [AUDIO] ..... 73
    - [CAMERA] ..... 65
    - Configuration ..... 60
    - Display ..... 61
    - Initialization ..... 63
    - [NETWORK] ..... 85
    - Operation ..... 62
    - [OTHERS] ..... 90
    - [RECORDING] ..... 83
    - [SCENE FILE] ..... 68
    - [SYSTEM] ..... 89
    - [THUMBNAIL] ..... 64
    - [VIDEO OUT/LCD/VF] ..... 75
  - Mirror shooting ..... 53
  - Mode check ..... 165
  - Monitor ..... 169
  - Multi manual function ..... 143
- N**
- ND filter ..... 111
  - Network ..... 174
    - Wireless LAN ..... 175
- O**
- Operation icon screen ..... 142
  - Optical image stabilizer function ..... 138
  - Output format
    - <HDMI> terminal ..... 158
    - <SDI OUT> terminal ..... 157
- P**
- Power
    - How to turn off the power ..... 37
    - How to turn on the power ..... 37
  - Pre-recording ..... 129
- R**
- RB gain control function ..... 121
  - Relay recording ..... 129
  - Remote control ..... 168
  - Remote operation ..... 172
  - Resume play ..... 154

**S**

Safety zone marker .....	135
Scene files .....	100
Screen display .....	57
Setup file .....	102
Shooting .....	104
Simultaneous recording .....	130
Skin tone function .....	121
Specifications .....	197
Still image recording function .....	155
Streaming function .....	180
Super gain .....	109
Super slow .....	124
Switching screen .....	58

**T**

Tally lamp .....	55
Thumbnail .....	146
Thumbnail screen .....	146
Time code .....	48
Time data .....	47
Time stamp function .....	140
Tripod .....	36
TV .....	169

**U**

Update .....	193
Usage restriction .....	192
USB .....	170
User bits .....	47
USER buttons	
Assignment .....	50
Check .....	52

**V**

Viewfinder .....	54
------------------	----

**W**

Warning system .....	188
Waveform monitor function .....	140
White balance .....	114
White clip function .....	122
Wireless LAN	
Direct connection .....	175
Wireless access point .....	176

**Z**

Zebra patterns .....	134
Zoom .....	118

## Useful Information (Only For Latin American Countries)

### Customer Service

#### Customer Service Directory

Obtain products information and operative assistant; localize the closer distributor or Service Center; buy spare parts and accessories by our Web Site to Latin America or calling our Contact Center:

COUNTRY	WEB SITE	CONTACT CENTER
Panama	<a href="http://www.panasonic.com/pa/soporte/">www.panasonic.com/pa/soporte/</a>	800-7262
Colombia	<a href="http://www.panasonic.com/co/soporte/">www.panasonic.com/co/soporte/</a>	01-8000-947262
Ecuador	<a href="http://www.panasonic.com/pa/soporte/">www.panasonic.com/pa/soporte/</a>	1-800-726276
Costa Rica	<a href="http://www.panasonic.com/pa/soporte/">www.panasonic.com/pa/soporte/</a>	800-7262737
El Salvador	<a href="http://www.panasonic.com/pa/soporte/">www.panasonic.com/pa/soporte/</a>	800-7262
Guatemala	<a href="http://www.panasonic.com/pa/soporte/">www.panasonic.com/pa/soporte/</a>	1-801-811-7262
Uruguay	<a href="http://www.panasonic.com/pa/soporte/">www.panasonic.com/pa/soporte/</a>	0-800-7262
Paraguay	<a href="http://www.panasonic.com/pa/soporte/">www.panasonic.com/pa/soporte/</a>	Web Site
Chile	<a href="http://www.panasonic.com/cl/soporte/">www.panasonic.com/cl/soporte/</a>	800-390-602 022-797-5000
Peru	<a href="http://www.panasonic.com/pe/soporte/">www.panasonic.com/pe/soporte/</a>	0800-00726
Venezuela	<a href="http://www.panasonic.com/pa/soporte/">www.panasonic.com/pa/soporte/</a>	Web Site
Mexico	<a href="http://www.panasonic.com/mx/soporte/">www.panasonic.com/mx/soporte/</a>	800-847-7262 55-5000-1200
Argentina		0800-333-7262 0810-321-7262
Dominican Rep.	<a href="http://www.panasonic.com/pa/soporte/">www.panasonic.com/pa/soporte/</a>	809-200-8000

For Caribbean countries that speak English please enter this web site in order to find information of our products and operative assistant:  
[www.panasonic.com/caribbean](http://www.panasonic.com/caribbean)

# Firmware Update

---

- **Firmware Ver. 1.4: F 2**

The firmware has been updated to improve performance and add functionality to the unit.  
The subsequent sections describe functions that have been added or modified.

- You can view the firmware version of the unit in the following menu:  
[OTHERS] menu → [INFORMATION] → [VERSION]
- For the latest information on the firmware or to download/update the firmware, visit the following support site:  
[https://panasonic.jp/support/global/cs/e\\_cam](https://panasonic.jp/support/global/cs/e_cam)  
(This website is in English only.)

# Firmware Ver. 1.4

---

- Functions Compatible with MP4 Added: F 3
- Support for Simultaneous Output from <SDI OUT> Terminal and <HDMI> Terminal [X2000]: F 4
- Configuration Menu Added for Focus Ring Operations: F 8
- Menu Setting Items Added: F 9
- Functional Improvements: F 10
- USER Button Functionality Added: F 11
- Added Menus: F 12

## Functions Compatible with MP4 Added

The MP4 file format is now available in the following functions:

### Background recording

[FREQUENCY]	[FILE FORMAT]	[REC FORMAT]
[59.94Hz]	[MP4]	[1080-59.94p/420LongGOP 50M] [1080-23.98p/420LongGOP 50M]
[50.00Hz]		[1080-50.00p/420LongGOP 50M]

### Interval recording

[FREQUENCY]	[FILE FORMAT]	[REC FORMAT]
[59.94Hz]	[MP4]	All
[50.00Hz]		

### Super slow recording

[FREQUENCY]	[FILE FORMAT]	[REC FORMAT]
[59.94Hz]	[MP4]	[1080-59.94p/420LongGOP 50M] [1080-23.98p/420LongGOP 50M]
[50.00Hz]		[1080-50.00p/420LongGOP 50M]

## Support for Simultaneous Output from <SDI OUT> Terminal and <HDMI> Terminal [X2000]

It is now possible to output from both the <SDI OUT> terminal and the <HDMI> terminal to external devices at the same time.

- Note regarding simultaneous output to the <SDI OUT> terminal and the <HDMI> terminal: F 4
- To set how to turn on/off the LCD monitor and viewfinder: F 5
- Notes on the composition of the [VIDEO OUT SEL], [SDI OUT], and [HDMI OUT] menus: F 6
- Notes on the FUNCTION screen in mode check: F 6
- Screen display during shooting: F 7

### Note regarding simultaneous output to the <SDI OUT> terminal and the <HDMI> terminal

It is possible to output from both the <SDI OUT> terminal and the <HDMI> terminal to the external device at the same time.

The formats that can be output differ depending on the following setting combinations.

- [SYSTEM] menu → [FREQUENCY]
- [SYSTEM] menu → [FILE FORMAT]
- [SYSTEM] menu → [REC FORMAT]
- [VIDEO OUT/LCD/VF] menu → [VIDEO OUT SEL] → [SDI OUT FORMAT]
- [VIDEO OUT/LCD/VF] menu → [VIDEO OUT SEL] → [HDMI OUT FORMAT]

Make the following menu setting:

- [VIDEO OUT/LCD/VF] menu → [VIDEO OUT SEL] → [SDI + HDMI OUTPUT] → [ON]

#### ■ When the [FREQUENCY] is set to [59.94Hz]

[REC FORMAT]	<HDMI> terminal	<SDI OUT> terminal
Resolution/frame rate	[HDMI OUT FORMAT]: output format	[SDI OUT FORMAT]: output format
3840×2160/59.94p	[3840×2160p]: 3840×2160/59.94p 4:2:2 10 bit [3840×2160p(420/8bit)]: 3840×2160/59.94p 4:2:0 8 bit [1920×1080p]*: 1920×1080/59.94p 4:2:2 10 bit	[1920×1080p]*: 1920×1080/59.94p 4:2:2 10 bit
	[1920×1080i]: 1920×1080/59.94i 4:2:2 10 bit	[1920×1080i]: 1920×1080/59.94i 4:2:2 10 bit
3840×2160/29.97p	[3840×2160p]: 3840×2160/29.97p 4:2:2 10 bit [1920×1080p]*: 1920×1080/29.97p 4:2:2 10 bit	[1920×1080p]: 1920×1080/29.97p 4:2:2 10 bit [1920×1080PsF]*: 1920×1080/29.97PsF 4:2:2 10 bit
	[3840×2160p]: 3840×2160/23.98p 4:2:2 10 bit [1920×1080p]*: 1920×1080/23.98p 4:2:2 10 bit	[1920×1080p]: 1920×1080/23.98p 4:2:2 10 bit [1920×1080PsF]*: 1920×1080/23.98PsF 4:2:2 10 bit
1920×1080/59.94p	[1920×1080p]*: 1920×1080/59.94p 4:2:2 10 bit	[1920×1080p]*: 1920×1080/59.94p 4:2:2 10 bit
	[1920×1080i]: 1920×1080/59.94i 4:2:2 10 bit	[1920×1080i]: 1920×1080/59.94i 4:2:2 10 bit
1920×1080/59.94i	[1920×1080i]: 1920×1080/59.94i 4:2:2 10 bit	[1920×1080i]: 1920×1080/59.94i 4:2:2 10 bit
1920×1080/29.97p	[1920×1080p]: 1920×1080/29.97p 4:2:2 10 bit	[1920×1080p]: 1920×1080/29.97p 4:2:2 10 bit [1920×1080PsF]*: 1920×1080/29.97PsF 4:2:2 10 bit
1920×1080/23.98p	[1920×1080p]: 1920×1080/23.98p 4:2:2 10 bit	[1920×1080p]: 1920×1080/23.98p 4:2:2 10 bit [1920×1080PsF]*: 1920×1080/23.98PsF 4:2:2 10 bit
1280×720/59.94p	[1280×720p]: 1280×720/59.94p 4:2:2 10 bit	[1280×720p]: 1280×720/59.94p 4:2:2 10 bit

■ When the [FREQUENCY] is set to [50.00Hz]

[REC FORMAT]	<HDMI> terminal	<SDI OUT> terminal
Resolution/frame rate	[HDMI OUT FORMAT]: output format	[SDI OUT FORMAT]: output format
3840×2160/50.00p	[3840×2160p]: 3840×2160/50.00p 4:2:2 10 bit [3840×2160p(420/8bit)]: 3840×2160/50.00p 4:2:0 8 bit [1920×1080p]*: 1920×1080/50.00p 4:2:2 10 bit	[1920×1080p]*: 1920×1080/50.00p 4:2:2 10 bit
	[1920×1080i]: 1920×1080/50.00i 4:2:2 10 bit	[1920×1080i]: 1920×1080/50.00i 4:2:2 10 bit
3840×2160/25.00p	[3840×2160p]: 3840×2160/25.00p 4:2:2 10 bit [1920×1080p]*: 1920×1080/25.00p 4:2:2 10 bit	[1920×1080p]: 1920×1080/25.00p 4:2:2 10 bit [1920×1080PsF]*: 1920×1080/25.00PsF 4:2:2 10 bit
1920×1080/50.00p	[1920×1080p]*: 1920×1080/50.00p 4:2:2 10 bit	[1920×1080p]*: 1920×1080/50.00p 4:2:2 10 bit
	[1920×1080i]: 1920×1080/50.00i 4:2:2 10 bit	[1920×1080i]: 1920×1080/50.00i 4:2:2 10 bit
1920×1080/50.00i	[1920×1080i]: 1920×1080/50.00i 4:2:2 10 bit	[1920×1080i]: 1920×1080/50.00i 4:2:2 10 bit
1920×1080/25.00p	[1920×1080p]: 1920×1080/25.00p 4:2:2 10 bit	[1920×1080p]: 1920×1080/25.00p 4:2:2 10 bit [1920×1080PsF]*: 1920×1080/25.00PsF 4:2:2 10 bit
1280×720/50.00p	[1280×720p]: 1280×720/50.00p 4:2:2 10 bit	[1280×720p]: 1280×720/50.00p 4:2:2 10 bit

\* Factory setting

**NOTE**

- There are the following limitations if [SDI + HDMI OUTPUT] is [ON]:
  - [HDMI OUT FORMAT] cannot be set to [720×480p]/[720×576p].
  - [SDI OUT FORMAT]/[HDMI OUT FORMAT] will have the same frame rate settings.  
(Example) When [HDMI OUT FORMAT]/[SDI OUT FORMAT] is set to [1920×1080p]  
If [HDMI OUT FORMAT] is set to [1920×1080i], then [SDI OUT FORMAT] will also be automatically set to [1920×1080i].
  - Either one of the LCD monitor or the viewfinder only illuminates.
- Set to the following settings in the menus when outputting only to the <SDI OUT> terminal.
  - [VIDEO OUT/LCD/VF] menu → [VIDEO OUT SEL] → [SDI + HDMI OUTPUT] → [OFF]
  - [VIDEO OUT/LCD/VF] menu → [VIDEO OUT SEL] → [EXTERNAL OUT SEL] → [SDI]
- Set to the following settings in the menus when outputting only to the <HDMI> terminal.
  - [VIDEO OUT/LCD/VF] menu → [VIDEO OUT SEL] → [SDI + HDMI OUTPUT] → [OFF]
  - [VIDEO OUT/LCD/VF] menu → [VIDEO OUT SEL] → [EXTERNAL OUT SEL] → [HDMI]
- When all of the following menu settings have been made, it is possible to control recording by external devices connected to the <SDI OUT> terminal and the <HDMI> terminal.
  - [VIDEO OUT/LCD/VF] menu → [VIDEO OUT SEL] → [SDI + HDMI OUTPUT] → [ON]
  - [VIDEO OUT/LCD/VF] menu → [SDI SETTING] → [SDI REC REMOTE] → [ON]
  - [VIDEO OUT/LCD/VF] menu → [HDMI SETTING] → [HDMI TC OUT] → [ON]
  - [VIDEO OUT/LCD/VF] menu → [HDMI SETTING] → [HDMI REC REMOTE] → [ON]

**To set how to turn on/off the LCD monitor and viewfinder**

Sets the display method of the LCD monitor/viewfinder when [VIDEO OUT/LCD/VF] menu → [VIDEO OUT SEL] → [SDI + HDMI OUTPUT] → [ON].

- 1 Select [VIDEO OUT/LCD/VF] menu → [VIDEO OUT SEL] → [LCD/VF OUTPUT] → [VF PRIORITY] or [LCD].

[VF PRIORITY]	When the viewfinder is closed, the LCD monitor turns on when the LCD monitor is opened. When the viewfinder is pulled out, the viewfinder turns on and the LCD monitor turns off.
[LCD]	The LCD monitor turns on when the LCD monitor is opened. The viewfinder does not turn on.

**To change the setting with a USER button**

You can change how to turn on/off the LCD monitor and Viewfinder by registering [LCD/VF OUTPUT] to a USER button.

- 1 When the recording screen is displayed, press the USER button to which [LCD/VF OUTPUT] is registered.

Switches the setting each time the button is pressed.

[VF PRIORITY] ↔ [LCD]

- The setting is also applied to the [VIDEO OUT/LCD/VF] menu → [VIDEO OUT SEL] → [LCD/VF OUTPUT] menu setting.



## Notes on the composition of the [VIDEO OUT SEL], [SDI OUT], and [HDMI OUT] menus

The compositions of the [VIDEO OUT SEL], [SDI OUT], and [HDMI OUT] menus have changed as follows:

### ■ [VIDEO OUT/LCD/VF] menu

Item	
[VIDEO OUT SEL]	[SDI + HDMI OUTPUT]
	[EXTERNAL OUT SEL]
	[SDI OUT FORMAT]
	[HDMI OUT FORMAT]
	[LCD/VF OUTPUT]
[SDI SETTING]	[SDI AUDIO GAIN CHG]
	[SDI REC REMOTE]
	[SDI OUT CHAR]
	[SDI OUT ZEBRA]
[HDMI SETTING]	[HDMI TC OUT]
	[HDMI REC REMOTE]
	[HDMI OUT CHAR]
	[HDMI OUT ZEBRA]

## Notes on the FUNCTION screen in mode check

There have been changes to the FUNCTION screen in mode check.

### ■ FUNCTION screen

Item		Description
[VIDEO OUT]	[VIDEO OUT SEL]	Displays the external output destination. <ul style="list-style-type: none"> <li>• [SDI+HDMI]: When [VIDEO OUT/LCD/VF] menu → [VIDEO OUT SEL] → [SDI + HDMI OUTPUT] is set to [ON]</li> <li>• [SDI]: When [VIDEO OUT/LCD/VF] menu → [VIDEO OUT SEL] → [EXTERNAL OUT SEL] is set to [SDI]</li> <li>• [HDMI]: When [VIDEO OUT/LCD/VF] menu → [VIDEO OUT SEL] → [EXTERNAL OUT SEL] is set to [HDMI]</li> </ul>
	[SDI OUT FORMAT]	Displays with [1920×1080p]/[1920×1080i]/[1920×1080PsF]/[1280×720p] the signals output through the <SDI OUT> terminal.
	[SDI OUT CHAR]	Displays with [ON]/[OFF] whether the characters output through the <SDI OUT> terminal are superimposed.
	[HDMI OUT FORMAT]	Displays with [3840×2160p]/[3840×2160p(420/8bit)]/[1920×1080p]/[1920×1080i]/[1280×720p]/[720×480p]/[720×576p] the signals output through the <HDMI> terminal.
	[HDMI OUT CHAR]	Displays with [ON]/[OFF] whether the characters output through the <HDMI> terminal are superimposed.
[CARD STATUS]	—	Displays the status, remaining recording capacity, and the total capacity of the memory card inserted in the card slot. The status of the memory card that is displayed are following types. <ul style="list-style-type: none"> <li>• [NO CARD]: Memory card is not inserted.</li> <li>• [UNSUPPORTED]: Memory card is not supported.</li> <li>• [FORMAT ERROR]: Memory card cannot be used. (Format error)</li> <li>• [PROTECTED]: It is write protected. (The write-protection switch of the memory card is set to the LOCK side)</li> <li>• [NO REMAIN]: There is no remaining recording capacity.</li> <li>• [NOT SDXC]: SDXC memory card is not inserted in the MOV recording/MP4 recording.</li> <li>• Cases other than above: The remaining recording capacity is displayed in 0% through 100%.</li> </ul>
	[TOTAL]	Displays the remaining recording capacity/total capacity of the memory cards in the card slot 1 and the card slot 2.
	[SLOT1]	Displays the status and remaining recording capacity/total capacity of the memory card in card slot 1.
	[SLOT2]	Displays the status and remaining recording capacity/total capacity of the memory card in card slot 2.

## Screen display during shooting

The following indicator has been added.

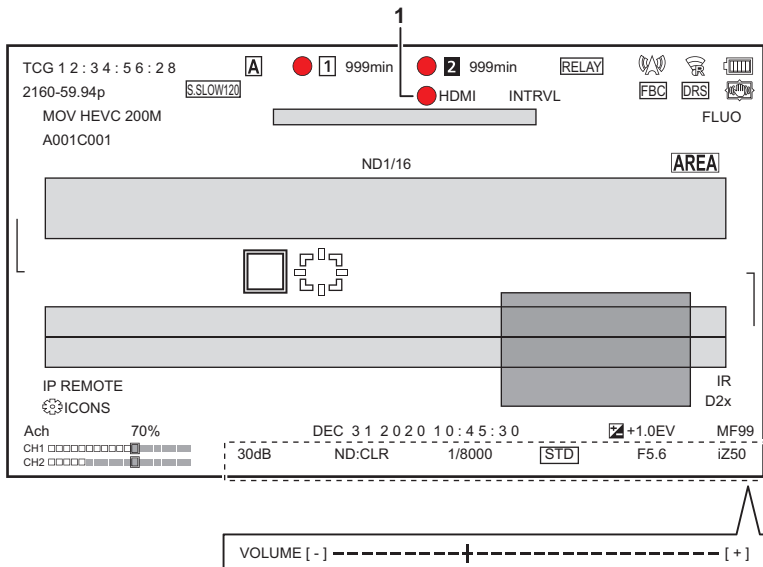

### 1 External equipment recording operation control status (<SDI OUT>/<HDMI> terminal)

Displays the control status of the recording start and recording stop on the external equipment connected to the <SDI OUT> terminal and the <HDMI> terminal.

- [● S/H]: Recording instruction is output to the output from the <SDI OUT> terminal/<HDMI> terminal.
- [S/H]: Pause instruction is output to the output from the <SDI OUT> terminal/<HDMI> terminal.

## Configuration Menu Added for Focus Ring Operations

### [FOCUS RING DRIVE]

[CAMERA] menu → [SW MODE] → [FOCUS RING DRIVE]

Switches the way focus is adjusted with the focus ring.

- Also set [FOCUS RING SETTING].

[NON-LINEAR]	The focus value changes according to the rotational speed and rotational position of the focus ring.
[LINEAR]	The focus value changes according to the rotational angle of the focus ring.

(Factory setting: [NON-LINEAR])

### [FOCUS RING SETTING]

[CAMERA] menu → [SW MODE] → [FOCUS RING SETTING]

#### ● When [FOCUS RING DRIVE] is set to [NON-LINEAR]

Sets the way focus is adjusted with the focus ring.

[SPEED]	Adjusts the focus value according to the speed at which the focus ring is rotated.
[COARSE]	Adjusts the focus value according to the rotational position of the focus ring. Since the operation of the focus ring results in a greater change in focus value, this setting is suitable for making rough adjustments.
[FINE]	Adjusts the focus value according to the rotational position of the focus ring. Since the operation of the focus ring results in a smaller change in focus value, this setting is suitable for making fine adjustments.

(Factory setting: [SPEED])

#### ● When [FOCUS RING DRIVE] is set to [LINEAR]

Sets the rotational angle of the focus ring.

The items that can be set are as follows.



- [90°], [120°], [150°], [180°], [210°], [240°], [270°], [300°], [330°], [360°]

(Factory setting: [180°])

## Menu Setting Items Added

### [FRAME MARKER]

[16:9] and [17:9] can now be set in [VIDEO OUT/LCD/VF] menu → [MARKER] → [FRAME MARKER].

[16:9]	[17:9]
	

## Functional Improvements

### Focus assist function

The focus assist function can now be used even when set to the auto mode or auto focus.

### Face detection/tracking AE&AF function

The face detection/tracking AE&AF function is available even when set to the manual mode.

#### **NOTE**

- The face detection frame is not displayed during manual focus.
- The mode does not switch to tracking mode even if you touch the screen during manual focus.
- During manual focus, the [FACE AF]/[FACE AFAE] display is crossed out.
- Even when [CAMERA] menu → [SW MODE] → [FACE DETECT/TRACKING MODE] → [FACE DETECT/TRACKING AE&AF] is set, exposure compensation does not work if auto iris, auto shutter, and auto gain are all disabled.
- The face detection/tracking AE&AF function is canceled when set to slow shutter.

#### ■ **Notes on the USER button function [FACE DETECT]**

Now available even when set to the manual mode.

#### **NOTE**

- In the following case, the USER button assigned to [FACE DETECT] cannot be used:
  - When set to slow shutter

### Super slow recording

When using the face detection/tracking AE&AF function, super slow can now be set. (The face detection/tracking AE&AF function is canceled.)

## USER Button Functionality Added

The following functionality has been added for the USER buttons.

\* Available for setting when using **X2000**.

Item (USER button icon display)	Description
[ONE PUSH A.IRIS] ([ONE PUSH A.IRIS])	Assigns the one push auto iris function.
[O.I.S. MODE] ([O.I.S. MODE])	Switches the operation mode of the optical image stabilizer function. Each time you either press the USER button or touch the USER button icon, the operation mode switches in the order [NORMAL], [PAN/TILT], [STABLE]
[REC SW] ([REC SW])	Assigns the same functions as the REC buttons.
[AUDIO CH1 LEVEL] ([AUDIO CH1 LEVEL])	Switches the recording level adjustment method for audio channel 1 between automatic and manual.
[AUDIO CH2 LEVEL] ([AUDIO CH2 LEVEL])	Switches the recording level adjustment method for audio channel 2 between automatic and manual.
[LCD/VF OUTPUT]* ([LCD/VF OUTPUT])	Switches the display method of the LCD monitor/viewfinder when [VIDEO OUT/LCD/VF] menu → [VIDEO OUT SEL] → [SDI + HDMI OUTPUT] → [ON].
[AUDIO OUT] ([AUDIO OUT])	Switches the audio channel and the format to output from the headphone terminal and the built-in speaker. Each time you either press the USER button or touch the USER button icon, the audio channel and the format switch in the order [CH1], [CH2], [CH1/2 STEREO], [CH1/2 MIX].

### One push auto iris function

In the manual iris mode, the USER button function [ONE PUSH A.IRIS] enables use of the following functionality.

One push auto iris function	By either pressing the USER button or touching the USER button icon, the mode switches to the auto iris mode and the iris (lens stop) is automatically adjusted. <ul style="list-style-type: none"> <li>• The mode returns to the manual iris mode when the automatic adjustments finish.</li> </ul>
Push auto iris function	While the USER button is being pressed, or the USER button icon is being touched and held, the mode temporarily switches to auto iris mode. <ul style="list-style-type: none"> <li>• When [AREA MODE] is set to [IRIS] or [FOCUS/IRIS] and the area function is used, the iris is automatically adjusted to suit the subject that was touched.</li> <li>• This is canceled when the USER button or USER button icon is released and the adjusted iris value is maintained.</li> </ul>

### NOTE

- [STD] is displayed on the screen during auto iris mode.
- The one push auto iris function cannot be used in the following cases:
  - In auto mode
  - In auto iris mode
  - In IR recording mode

## Added Menus

Specifications information for the menus added by the firmware update.

### Target items for scene file/setup file/initialization

- SCENE: Items saved in scene files.
- SETUP: Items saved in setup files.
- INITIALIZE: Items that are initialized with the [OTHERS] menu → [MENU INITIALIZE].
- Meaning of the symbols used in the table are as follows.
  - ✓: Is a target.
  - —: Not a target.

\* Available for setting when using [X2000].

#### ■ [CAMERA] menu

Item		SCENE	SETUP	INITIALIZE
[SW MODE]	[FOCUS RING DRIVE]	—	✓	✓
	[FOCUS RING SETTING]	—	✓	✓

#### ■ [VIDEO OUT/LCD/VF] menu

Item		SCENE	SETUP	INITIALIZE
[VIDEO OUT SEL]*	[SDI + HDMI OUTPUT]	—	✓	✓
	[EXTERNAL OUT SEL]	—	✓	✓
	[SDI OUT FORMAT]	—	✓	✓
	[HDMI OUT FORMAT]	—	✓	✓
	[LCD/VF OUTPUT]	—	✓	✓
[SDI SETTING]*	[SDI AUDIO GAIN CHG]	—	✓	✓
	[SDI REC REMOTE]	—	✓	✓
	[SDI OUT CHAR]	—	✓	✓
	[SDI OUT ZEBRA]	—	✓	✓
[HDMI SETTING]*	[HDMI TC OUT]	—	✓	✓
	[HDMI REC REMOTE]	—	✓	✓
	[HDMI OUT CHAR]	—	✓	✓
	[HDMI OUT ZEBRA]	—	✓	✓