

English

How to fit the earphones

Fit the earphones correctly in order to get adequate noise cancelling effect and acoustics. Select and fit the special earpieces that suit the sizes of your ears, left and right.

How to fit the earphones (🕒)

- 1 Check the orientation (up (🕒), down) and L (left) and R (right) of the earphones.
- 2 Fit firmly by turning the earphones a small amount at a time in the directions indicated by the arrow in the illustration.

- Confirm that the earphones will not fall from your ears after you have fitted them.
- If the earphones fall out easily, replace with earpieces (supplied) of a different size.
- The left earphone has a raised dot indicating the L side.

Select the earpieces

- How to remove the earpieces (🕒)
- How to attach the earpieces (🕒)
- Make sure the earpieces are fitted firmly into your ears and confirm that they are not at an angle.

Français

Comment positionner les écouteurs

Positionnez correctement les écouteurs pour que les effets de réduction de bruit et acoustiques soient correctement obtenus. Choisissez et positionnez les oreillettes spéciales adaptées à la taille de vos oreilles, gauche et droite.

Comment positionner les écouteurs (🕒)

- 1 Vérifiez l'orientation (haut (🕒), bas) et le côté L (gauche) et R (droit) des écouteurs.
- 2 Positionnez correctement en tournant légèrement à chaque fois les écouteurs dans le sens indiqué par la flèche sur l'illustration.

- Vérifiez que les écouteurs ne tombent pas de vos oreilles une fois positionnés.
- Si les écouteurs tombent facilement, remplacez les oreillettes (fournies) par d'autres d'une taille différente.
- L'écouteur gauche est doté d'un détrompeur (picot surélevé) qui indique le côté L.

Choisir les oreillettes

- Comment retirer les oreillettes (🕒)
- Comment mettre en place les oreillettes (🕒)
- Assurez-vous que les oreillettes sont correctement positionnées dans vos oreilles et vérifiez qu'elles ne sont pas inclinées.

Deutsch

Einsetzen der Ohrhörer

Setzen Sie die Ohrhörer richtig ein, um eine zufriedenstellende Geräuschunterdrückung und Akustik zu erzielen. Wählen und nutzen Sie die Ohrstöpsel, die zur Größe Ihrer Ohren (links und rechts) passen.

Einsetzen der Ohrhörer (🕒)

- 1 Überprüfen Sie die Ausrichtung der Ohrhörer: (oben (🕒), unten) bzw. L (links) und R (rechts).
- 2 Um einen festen Sitz zu erzielen, drehen Sie die Ohrhörer beim Einsetzen entsprechend dem abgebildeten Pfeil ein wenig hin und her.

- Vergewissern Sie sich nach dem Einsetzen, dass die Ohrhörer nicht aus Ihren Ohren herausfallen können.
- Wenn die Ohrhörer leicht herausfallen, ersetzen Sie die Ohrstöpsel (mitgeliefert) durch eine andere Größe.
- Auf dem linken Ohrhörer befindet sich als Kennzeichnung der L-Seite eine punktförmige Erhebung.

Entwählen der Ohrstöpsel

- Auswahlen der Ohrstöpsel (🕒)
- Anbringen der Ohrstöpsel (🕒)
- Vergewissern Sie sich, dass die Ohrhörer fest in Ihren Ohren sitzen und nicht schief eingesetzt sind.

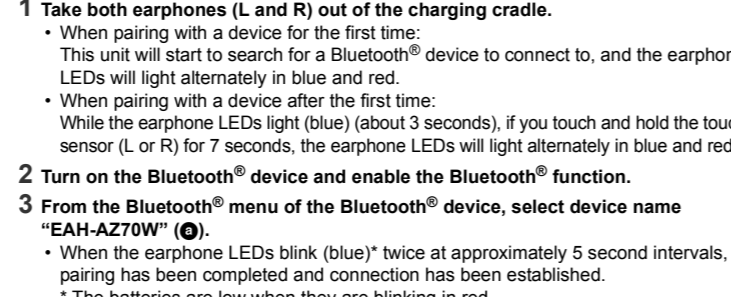
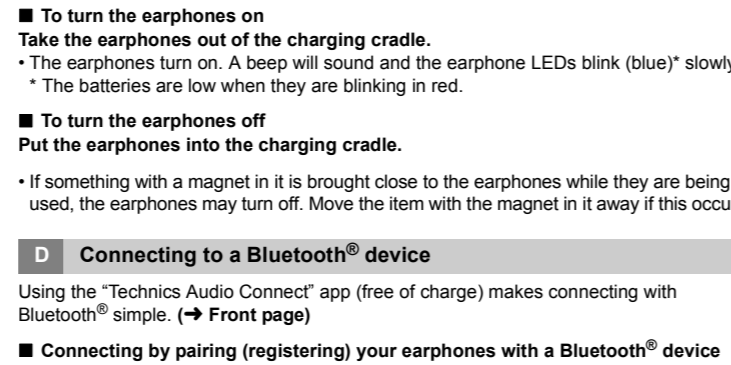
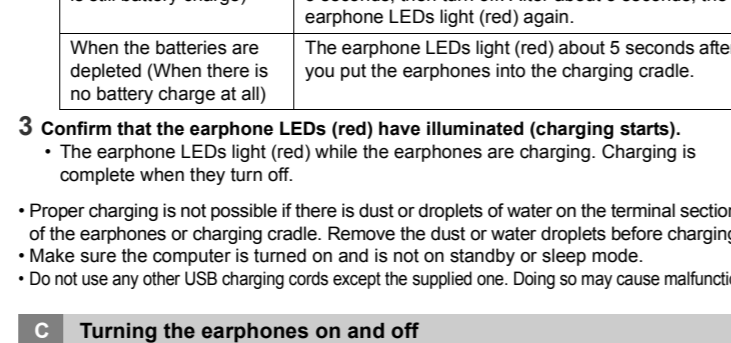
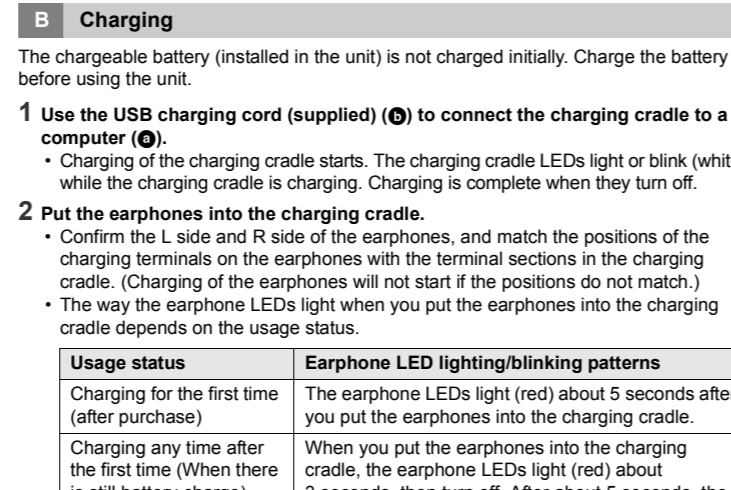
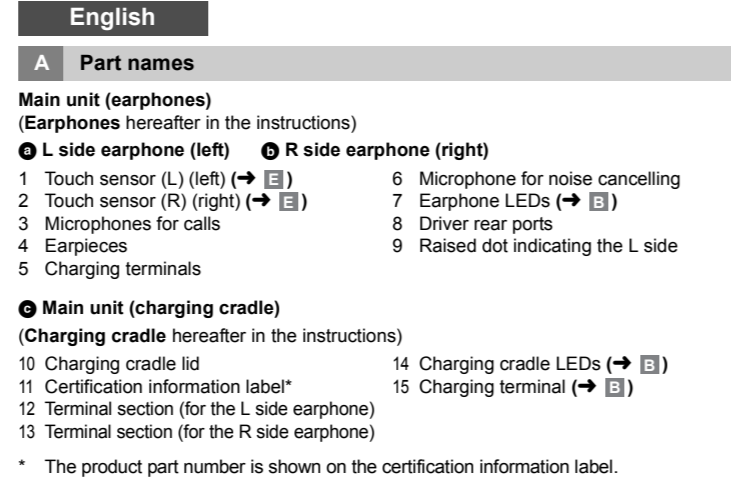
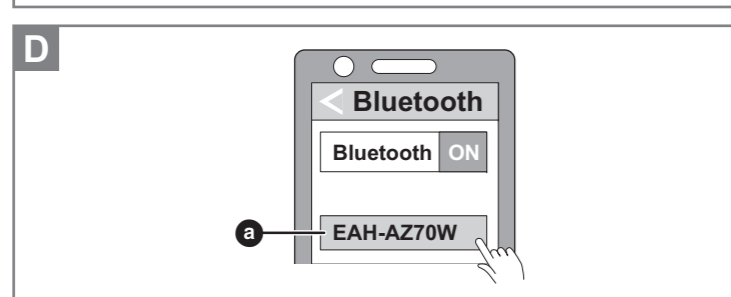
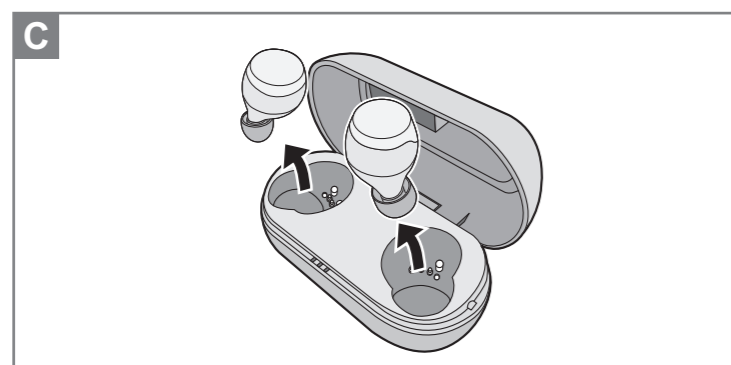
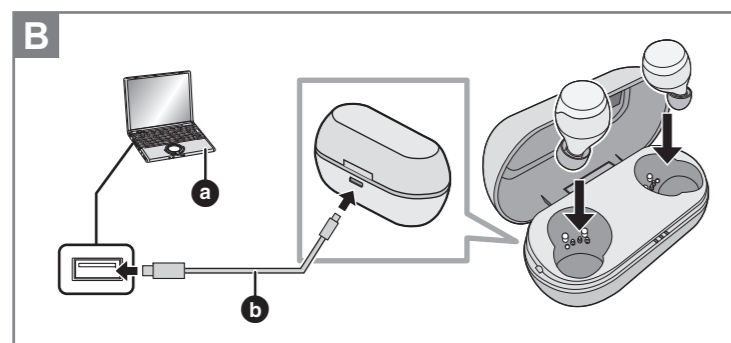
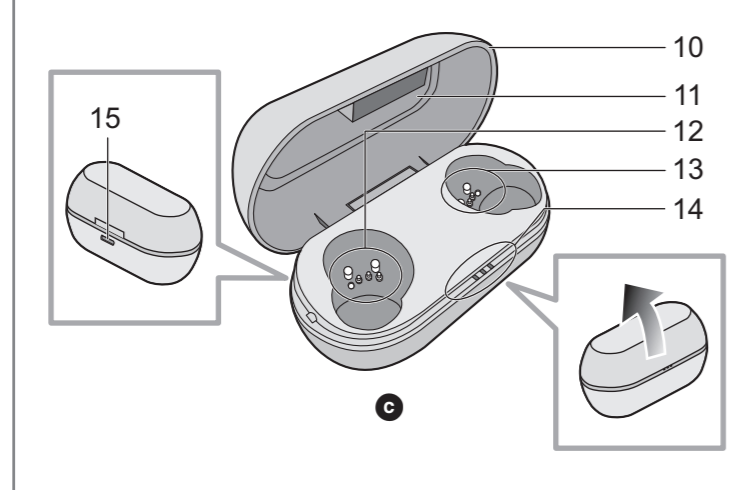
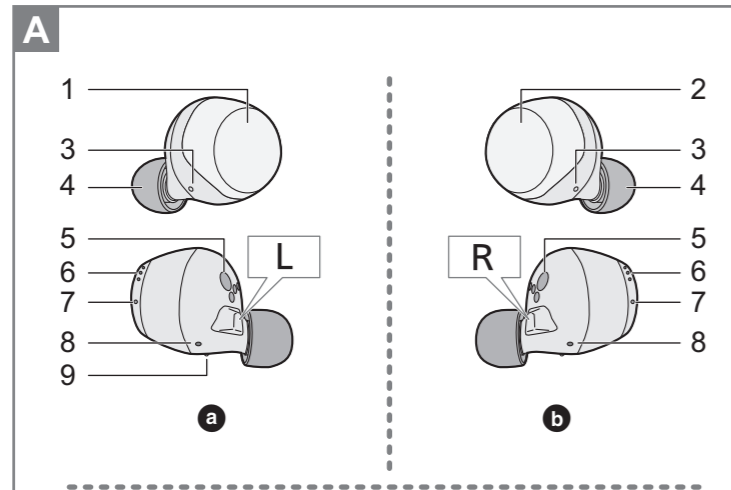

If the connection with the device does not complete within 5 minutes, the pairing mode on the earphones cancels and they transition to connection standby mode. Perform pairing again.

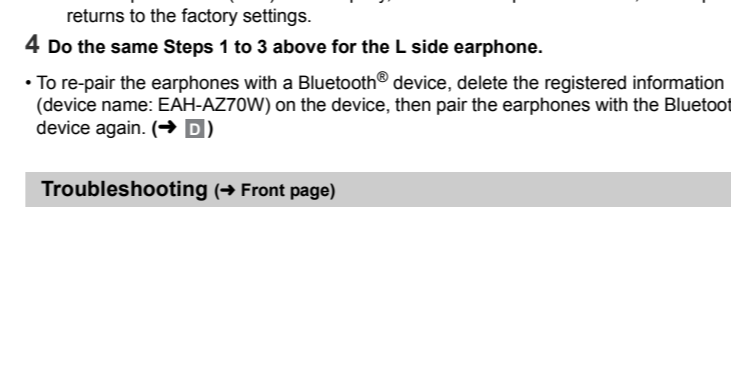
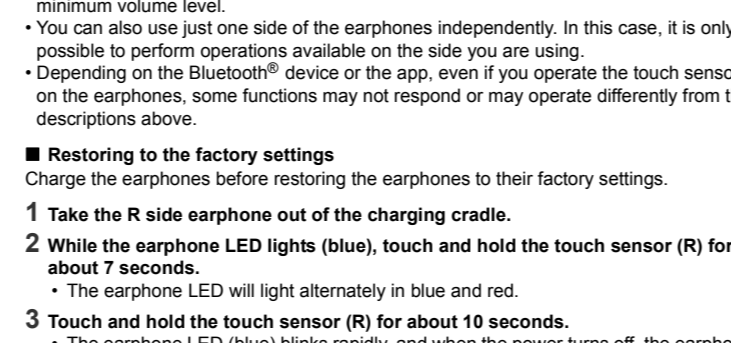
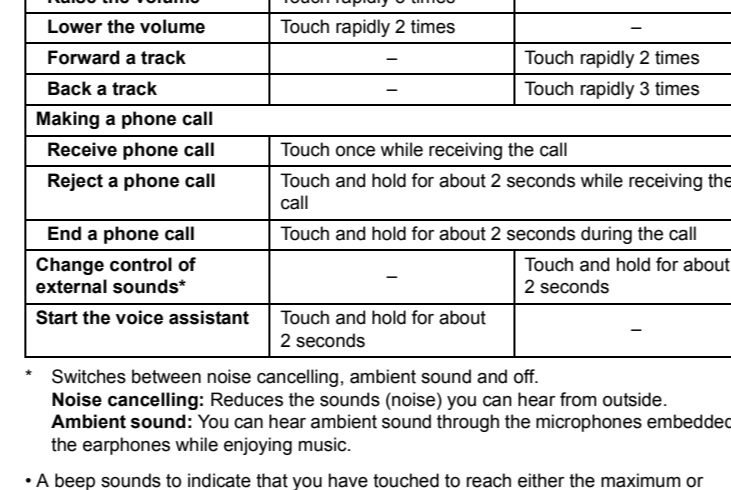
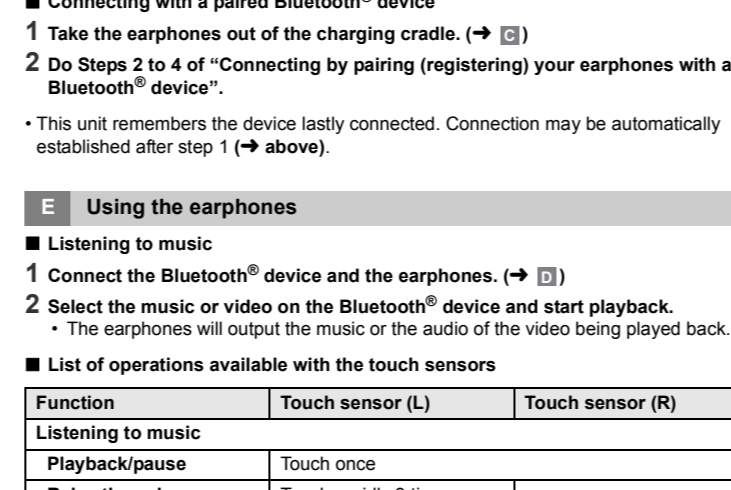

If the connection with the device does not complete within 5 minutes, the pairing mode on the earphones cancels and they transition to connection standby mode. Perform pairing again.

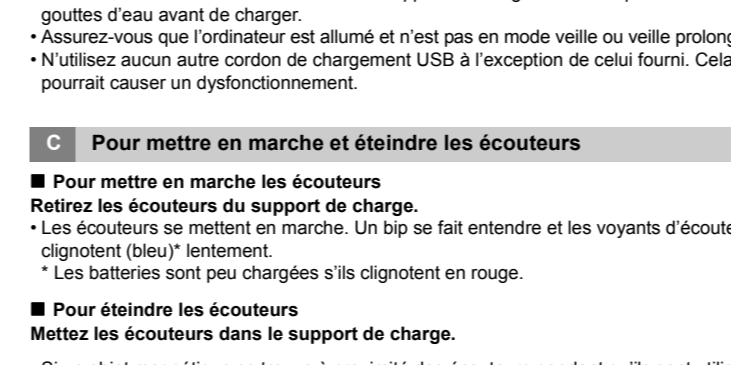
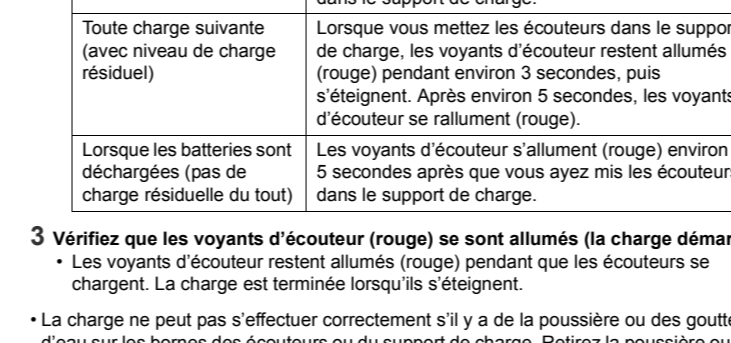
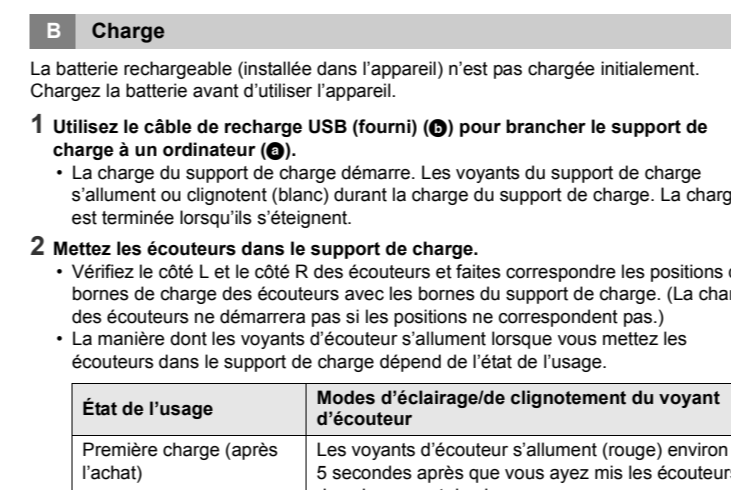
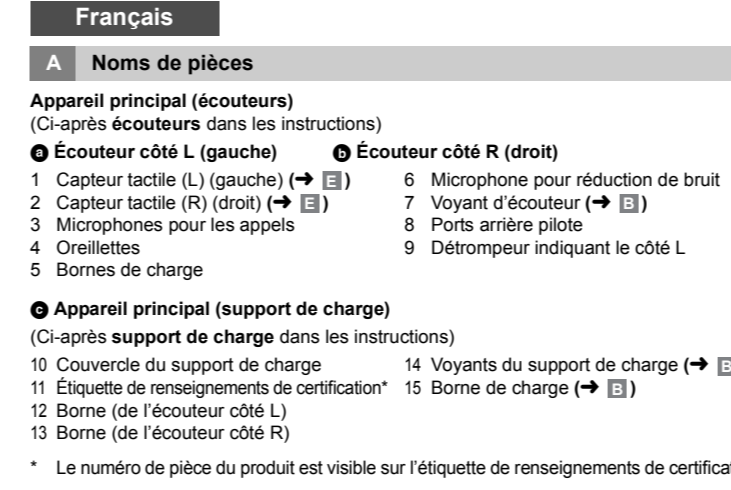

If the connection with the device does not complete within 5 minutes, the pairing mode on the earphones cancels and they transition to connection standby mode. Perform pairing again.

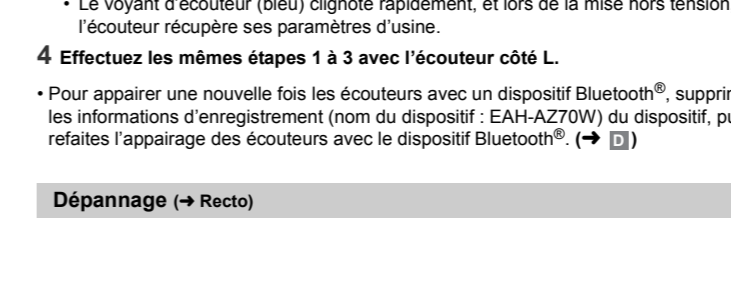
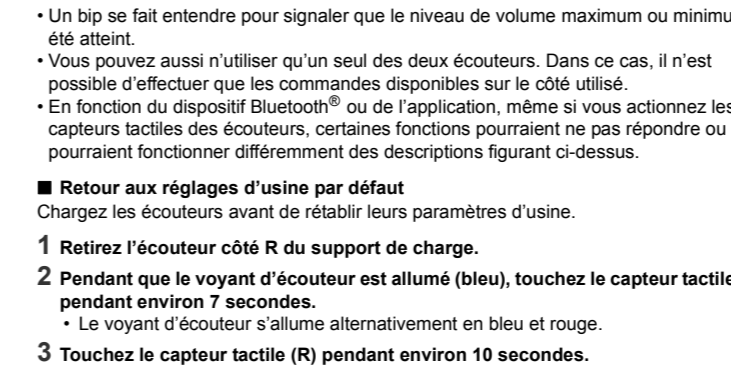
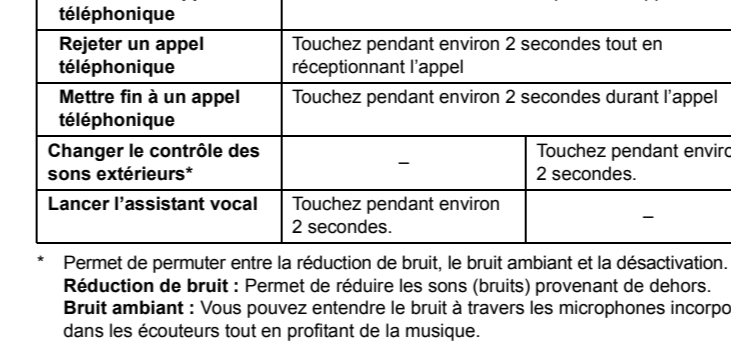
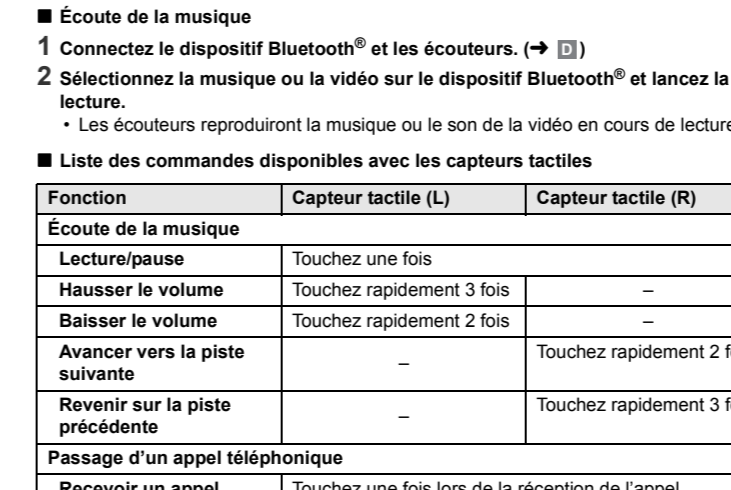
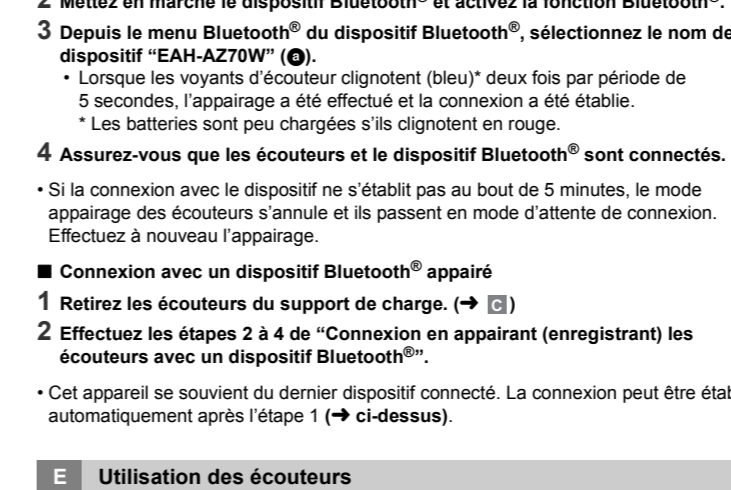

If the connection with the device does not complete within 5 minutes, the pairing mode on the earphones cancels and they transition to connection standby mode. Perform pairing again.

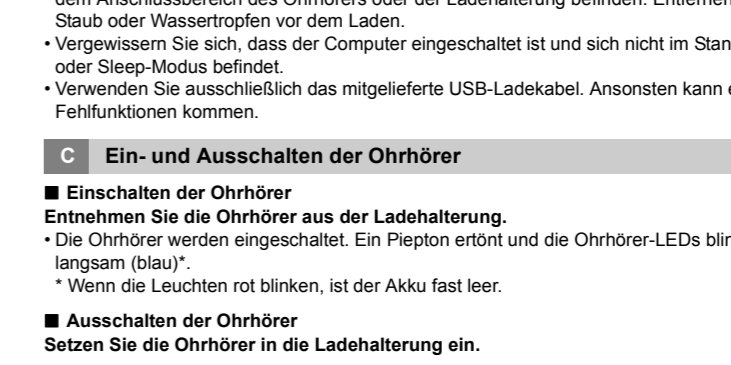
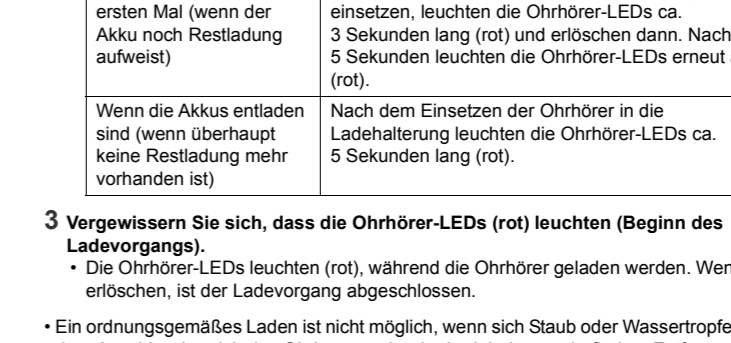
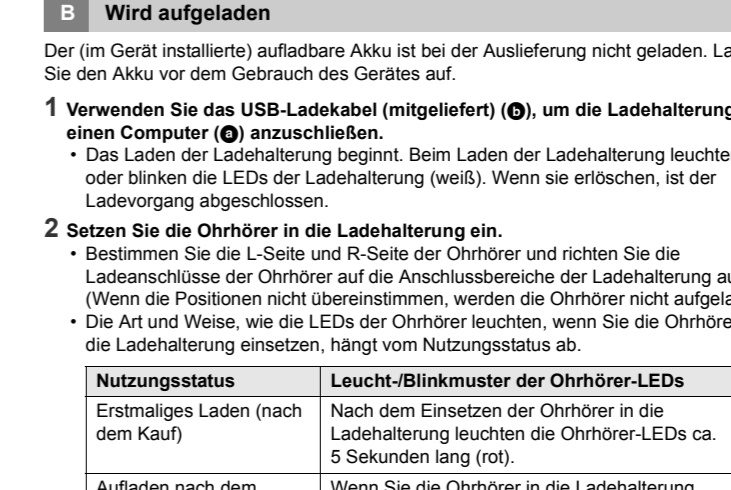
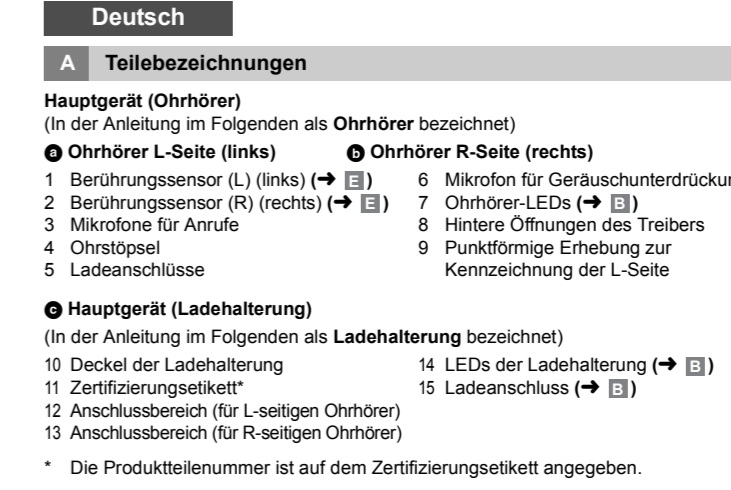

If the connection with the device does not complete within 5 minutes, the pairing mode on the earphones cancels and they transition to connection standby mode. Perform pairing again.

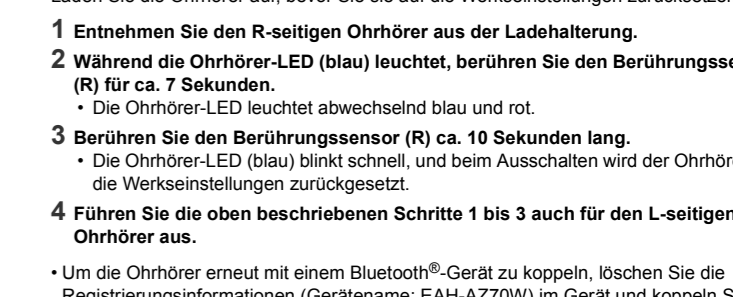
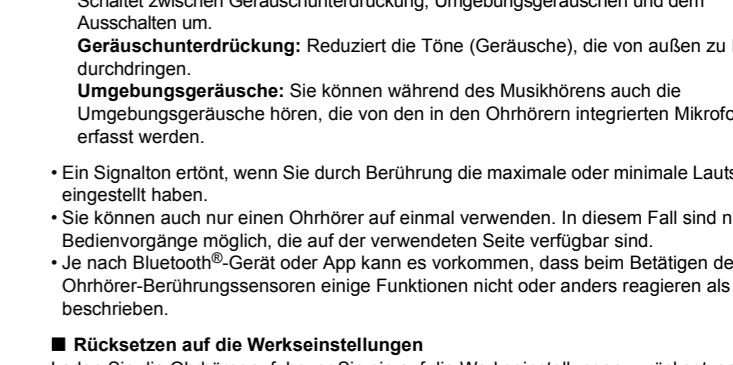
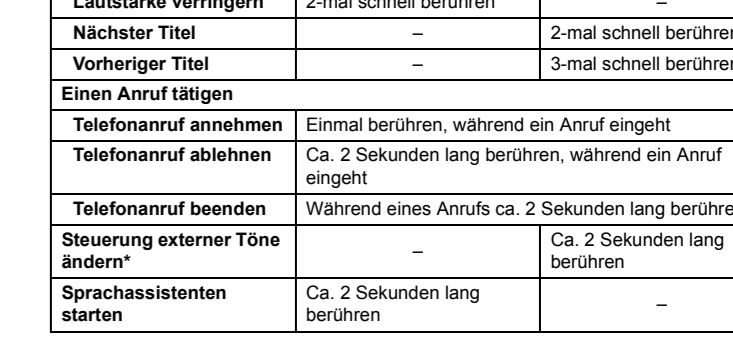
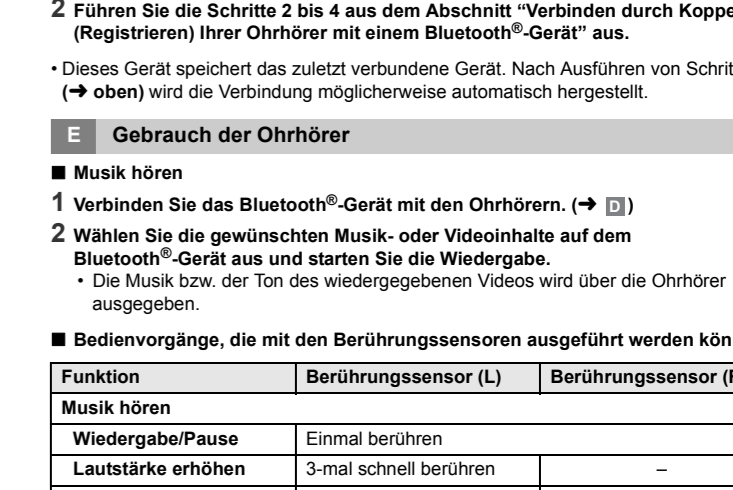
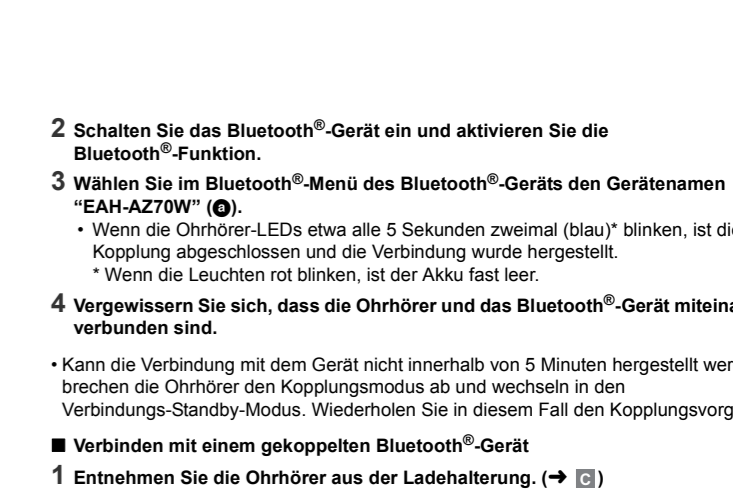

If the connection with the device does not complete within 5 minutes, the pairing mode on the earphones cancels and they transition to connection standby mode. Perform pairing again.

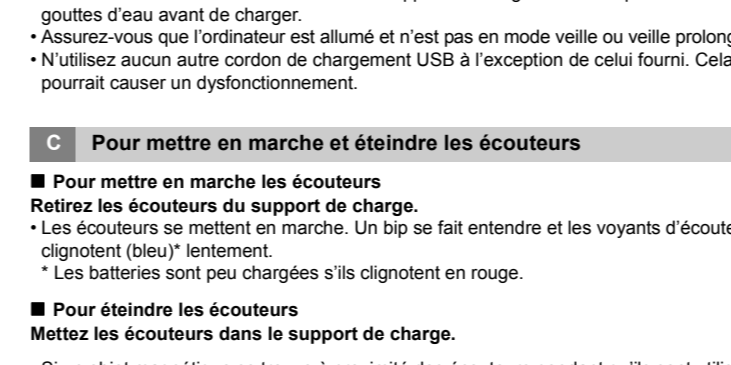
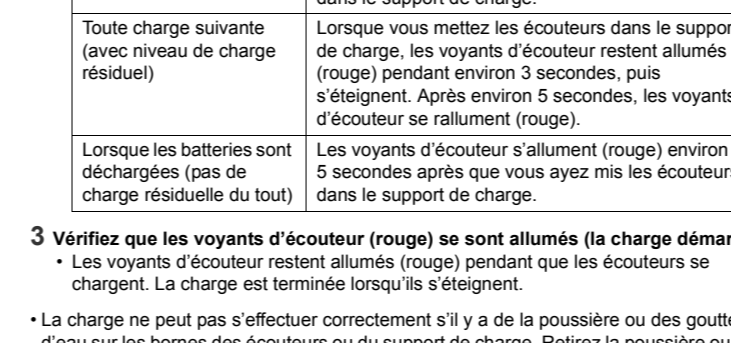
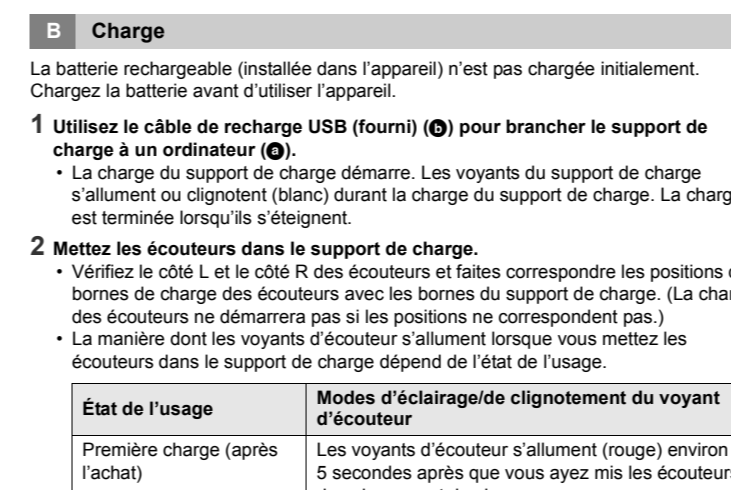
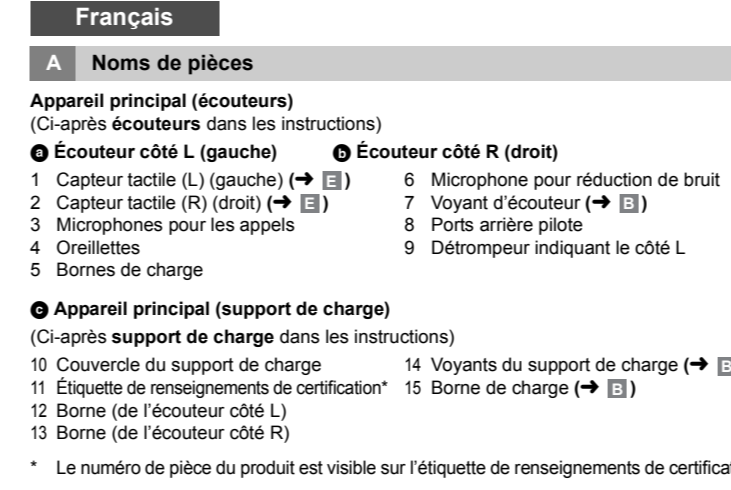

If the connection with the device does not complete within 5 minutes, the pairing mode on the earphones cancels and they transition to connection standby mode. Perform pairing again.

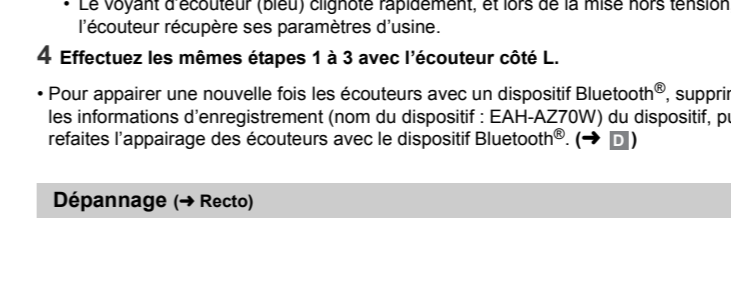
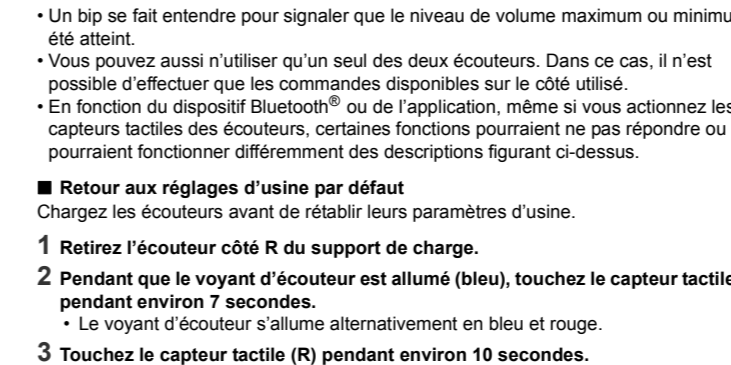
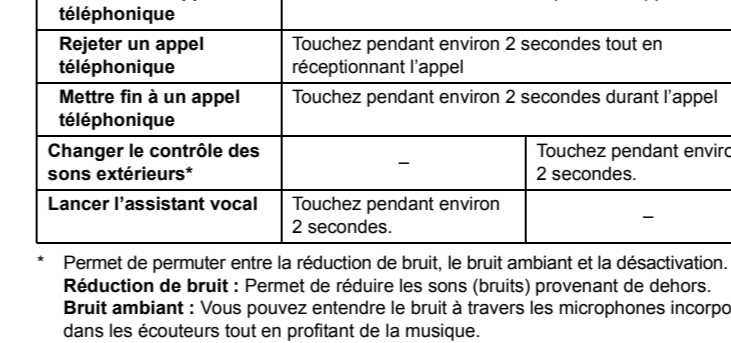
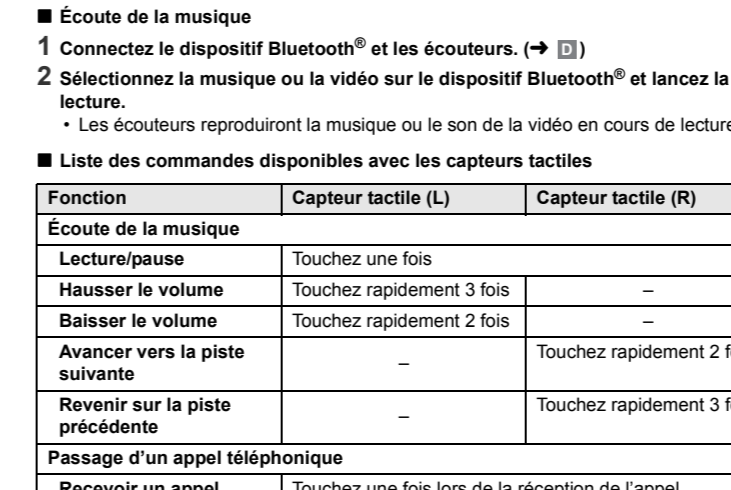
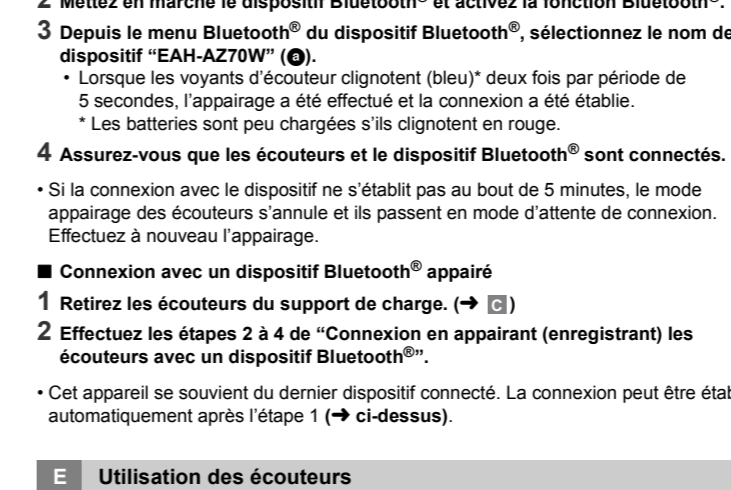

If the connection with the device does not complete within 5 minutes, the pairing mode on the earphones cancels and they transition to connection standby mode. Perform pairing again.

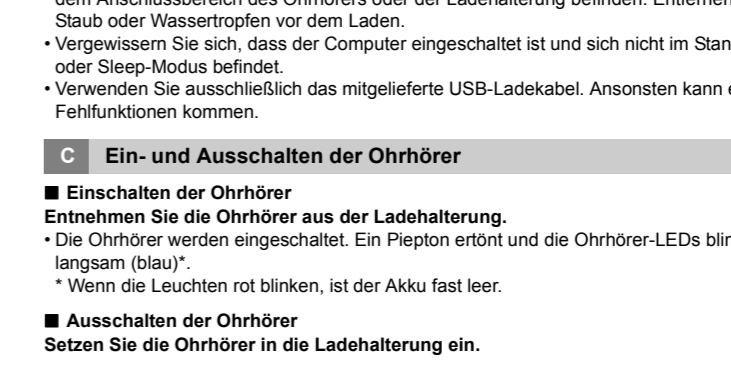
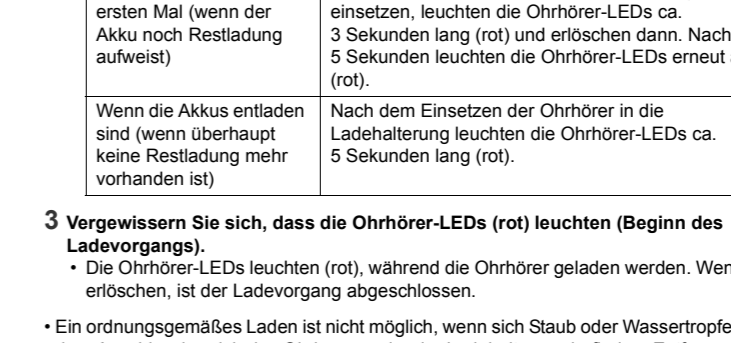
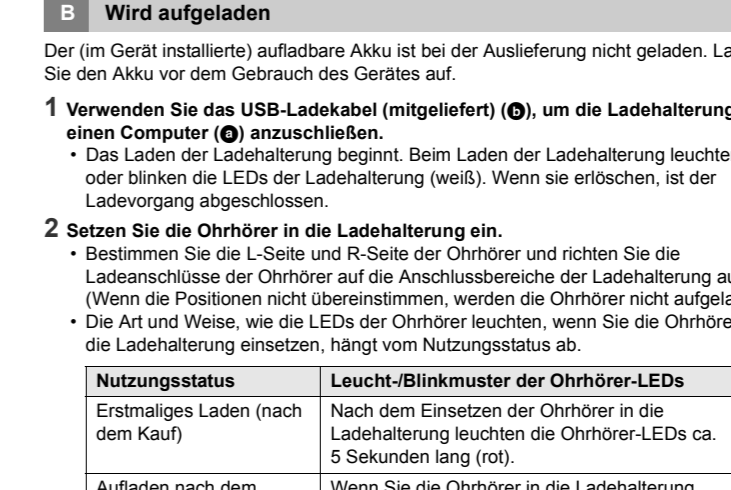
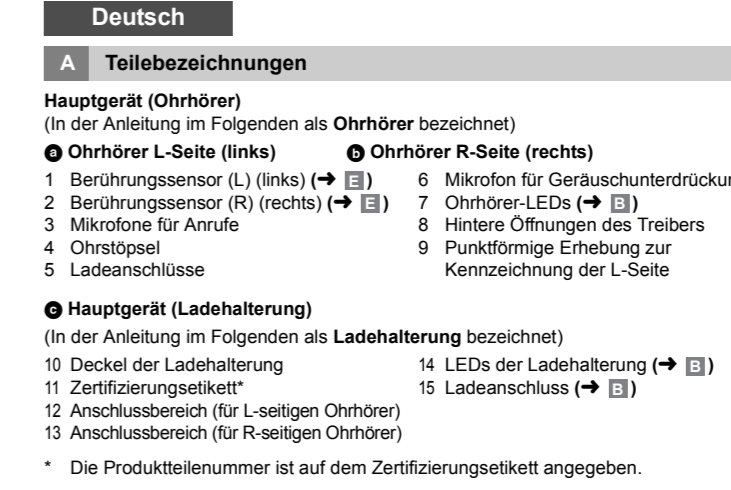

If the connection with the device does not complete within 5 minutes, the pairing mode on the earphones cancels and they transition to connection standby mode. Perform pairing again.

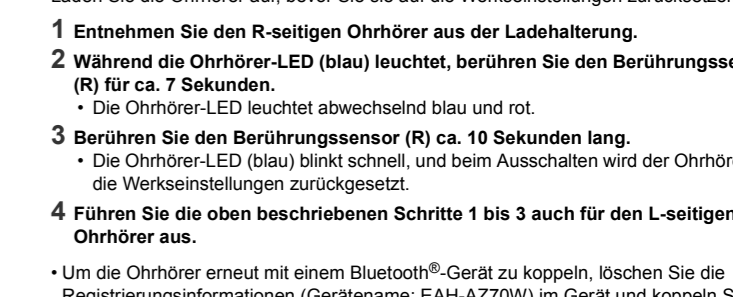
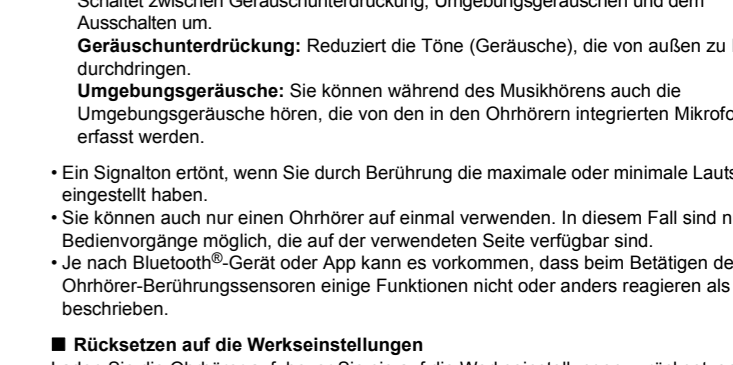
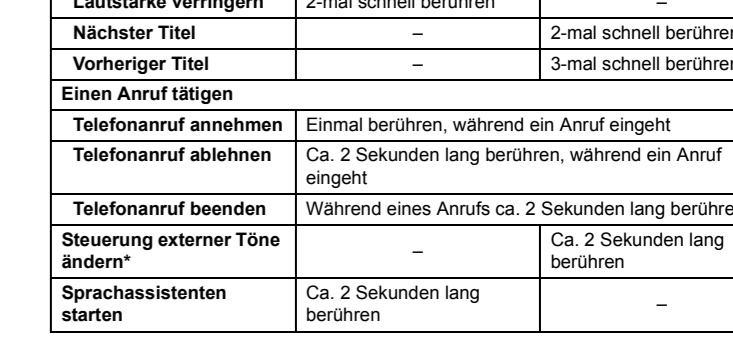
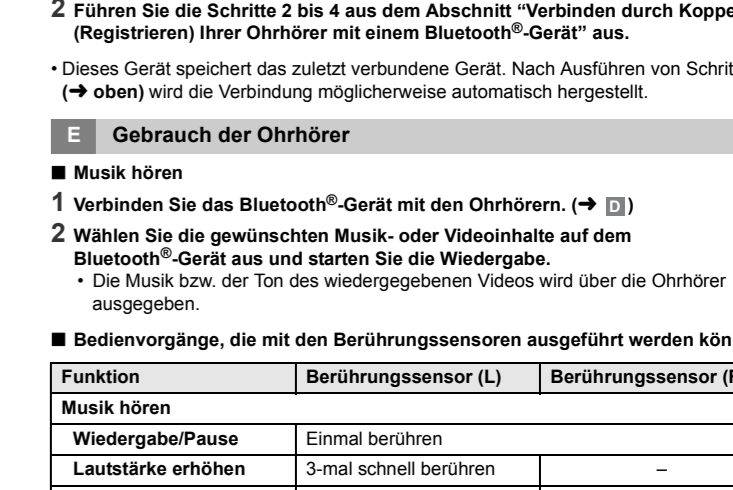
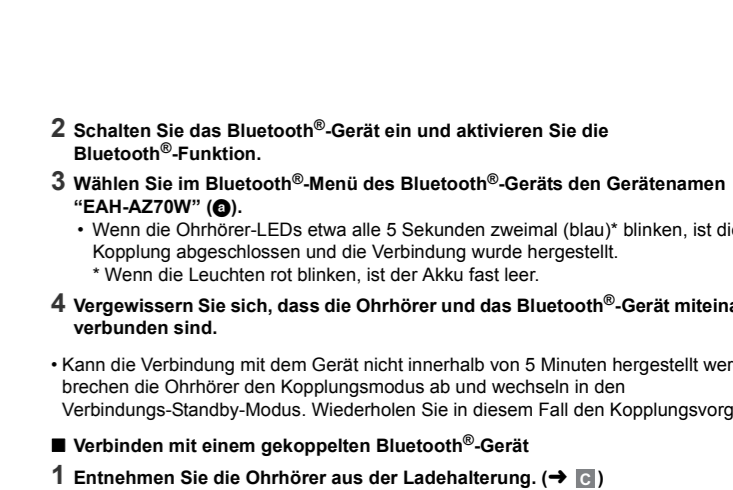

If the connection with the device does not complete within 5 minutes, the pairing mode on the earphones cancels and they transition to connection standby mode. Perform pairing again.